





This drawing and the information contained thereon remain the property of BeaconMedes and may not be used for other than the purpose for which it is loaned without the expressed written permission from BeaconMedes Engineering.

Notes:

1. SYSTEM WEIGHT: 612 LB
2.  INDICATES LIFTING POINTS
3.  DENOTES CENTER OF GRAVITY

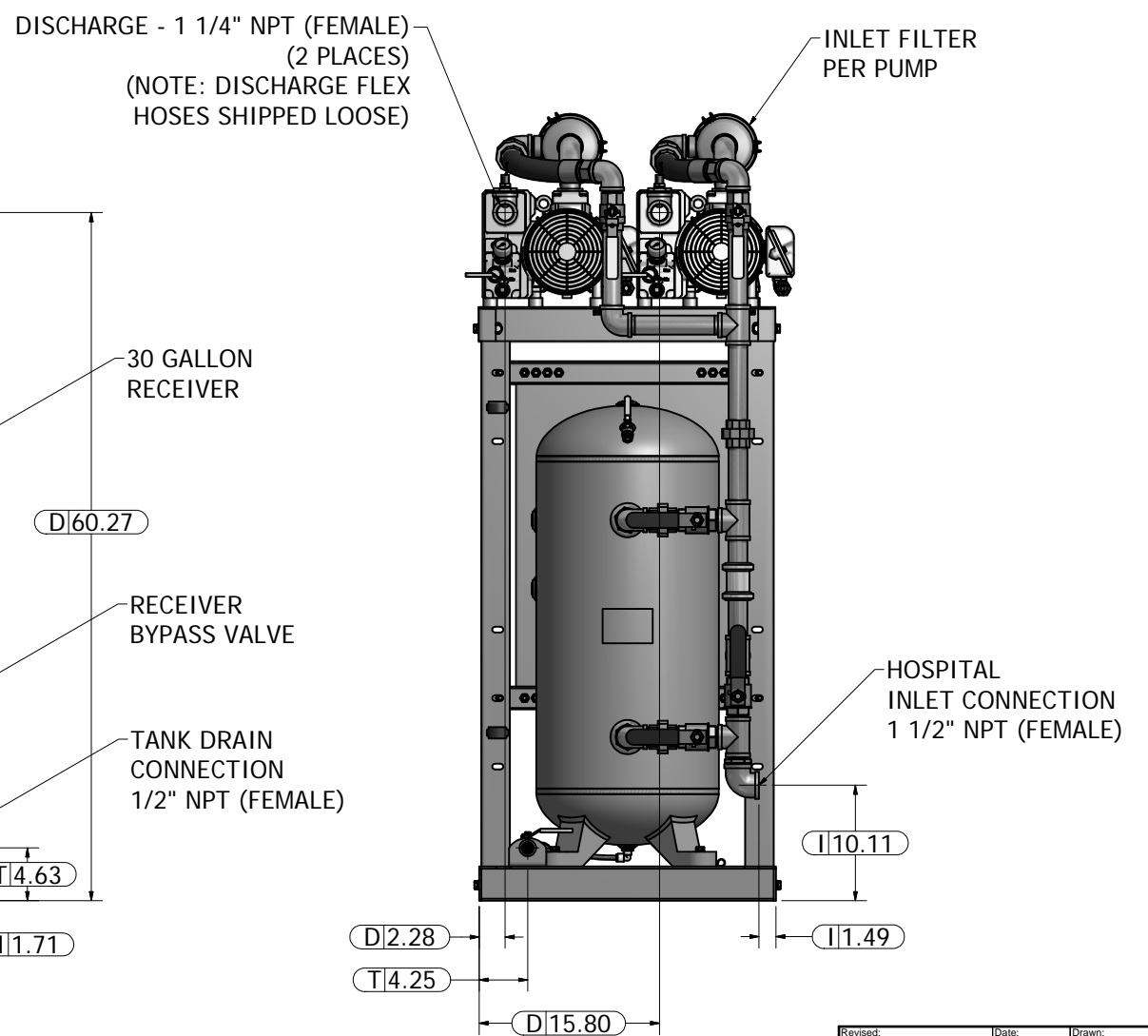
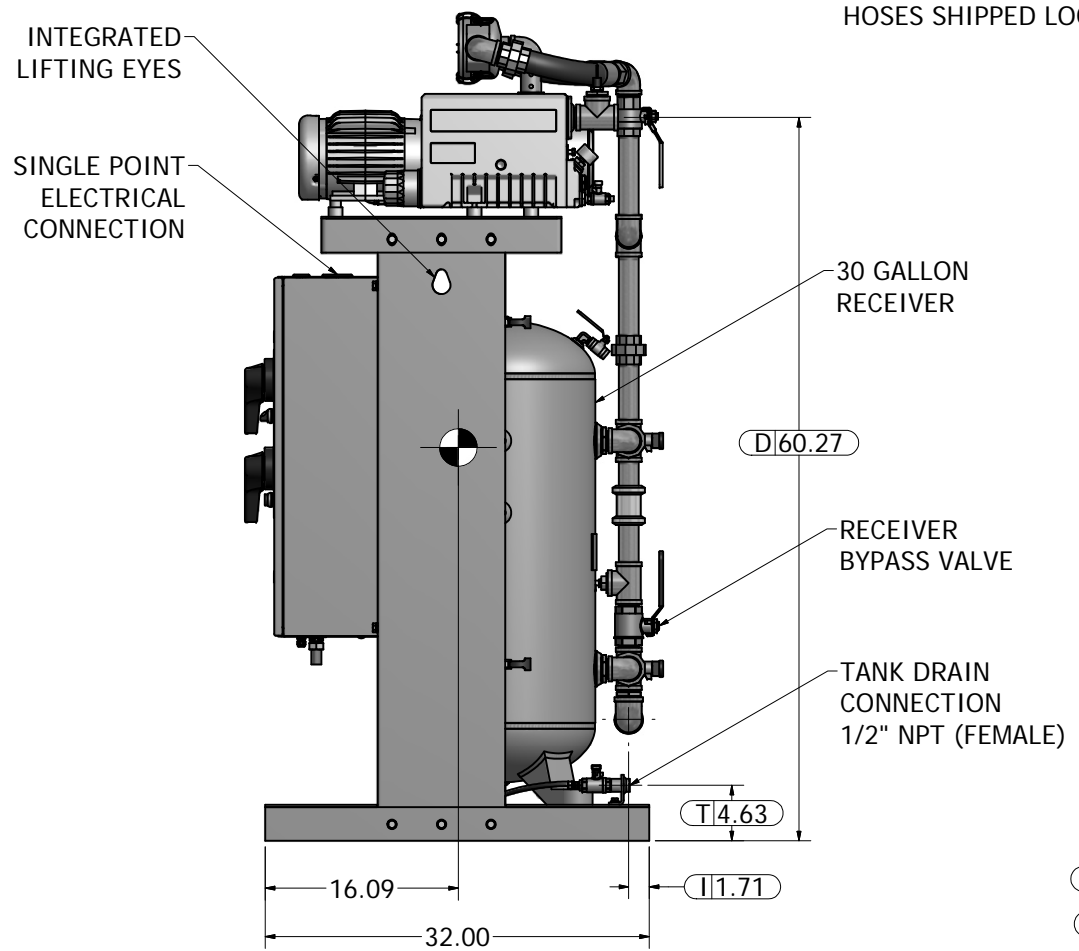
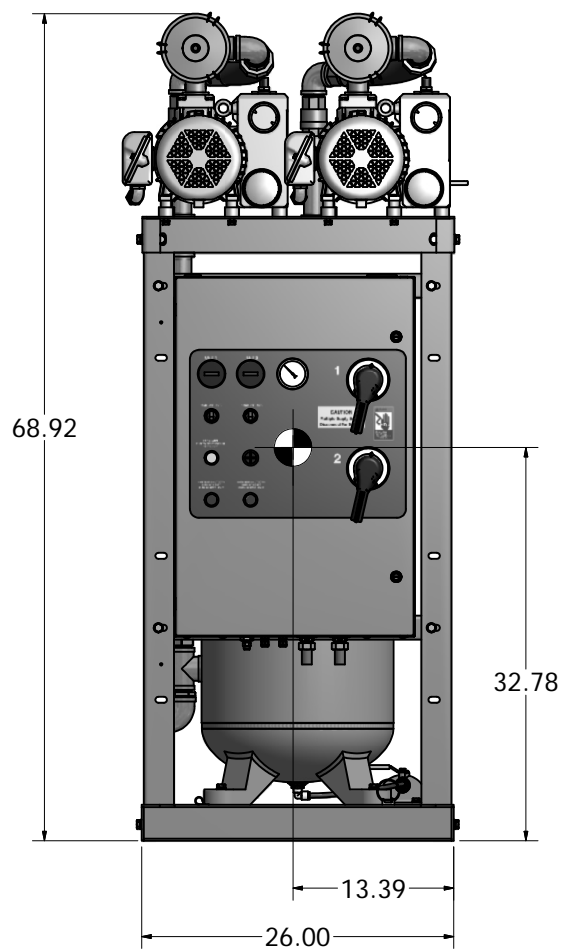
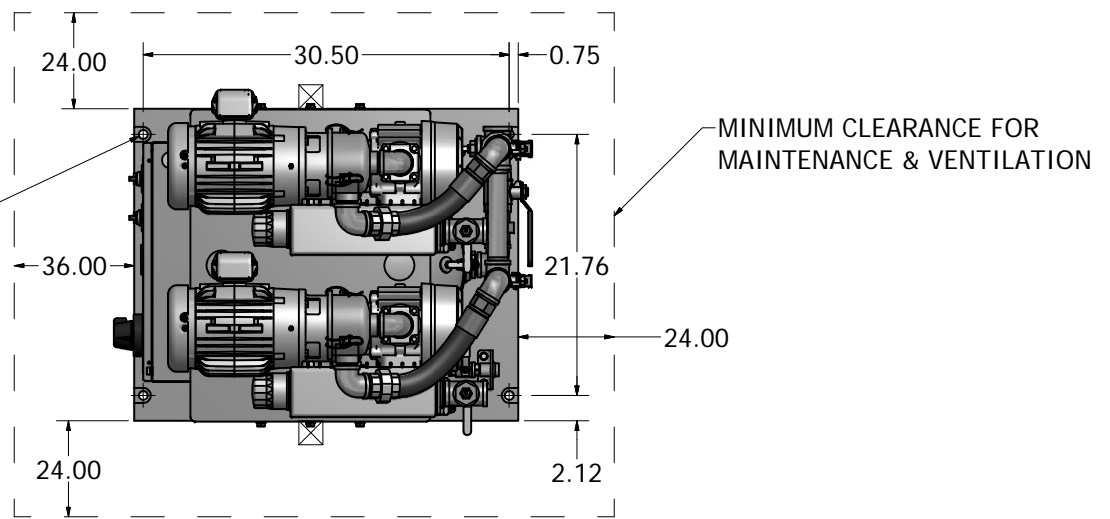
SYSTEM CONNECTIONS	
ID	DESCRIPTION
I	INLET LOCATION
D	DISCHARGE LOCATION
T	TANK DRAIN



Revised: JOL	Date: 12/11/15	Drawn: JOL	Date: 07/13/15
INSPECTION CHECKLIST UNLESS OTHERWISE SPECIFIED:   ALL ITEMS MARKED BY ONE OF THE ABOVE SYMBOLS ARE TO BE INSPECTED EQUIPMENT TO BE USED DURING RECEIVING INSPECTION SHALL BE PER QUALITY SYSTEM PROCEDURES		BEACONMEDES Description: GENERAL ASSEMBLY DX 1.5HP LUBE VTM V 30G BASIC	Scale: 1/8 Part Number: 4107 8553 35 DN: HOP151415 Rev: 01 Sheet 1 of 1 DO NOT SCALE THIS DOCUMENT