



This drawing and the information contained thereon remain the property of BeaconMedes and may not be used for other than the purpose for which it is loaned without the expressed written permission from BeaconMedes Engineering.

- Notes:
1. SYSTEM WEIGHT: 640 LB
 2.  INDICATES LIFTING POINTS
 3.  DENOTES CENTER OF GRAVITY

SYSTEM CONNECTIONS	
ID	DESCRIPTION
I	INLET LOCATION
D	DISCHARGE LOCATION
T	TANK DRAIN

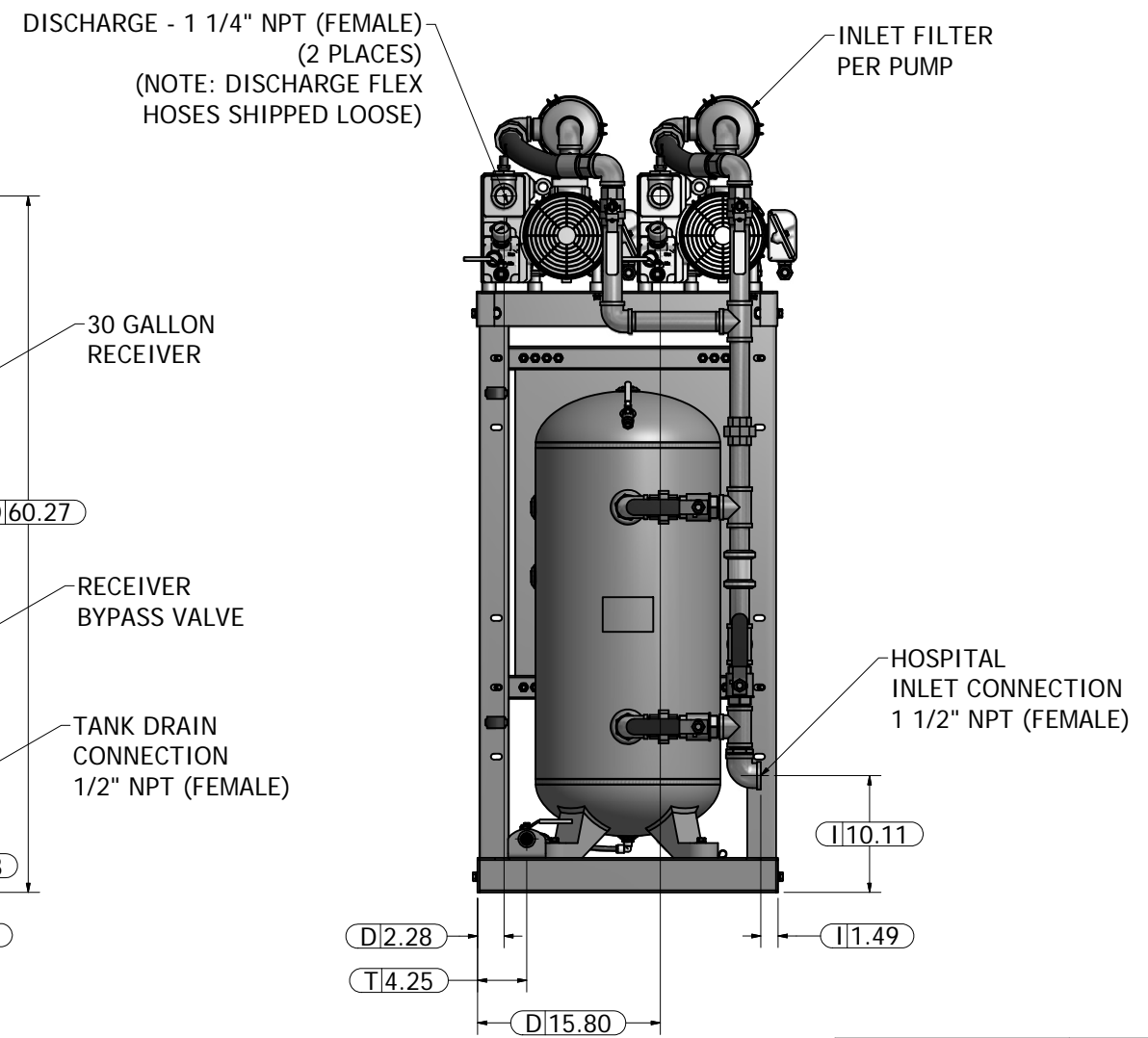
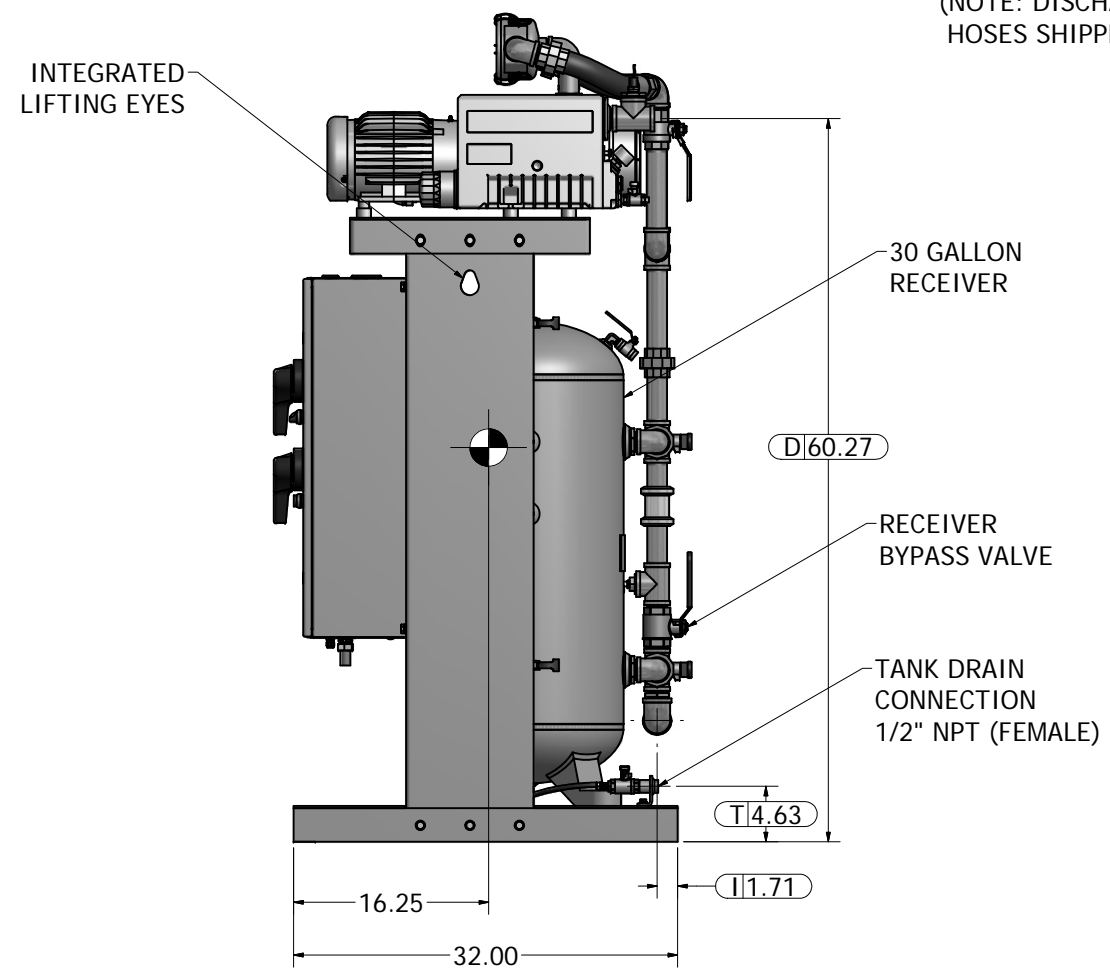
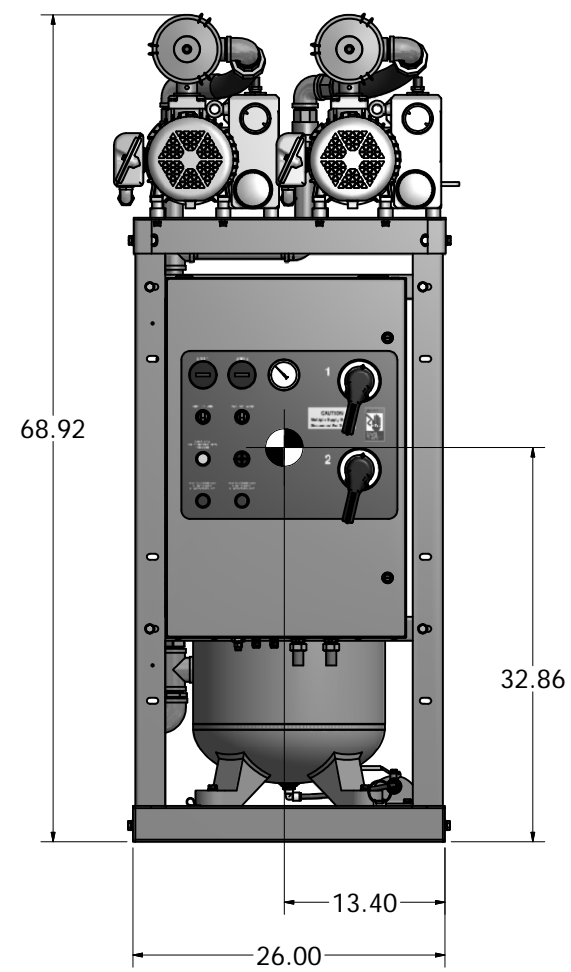
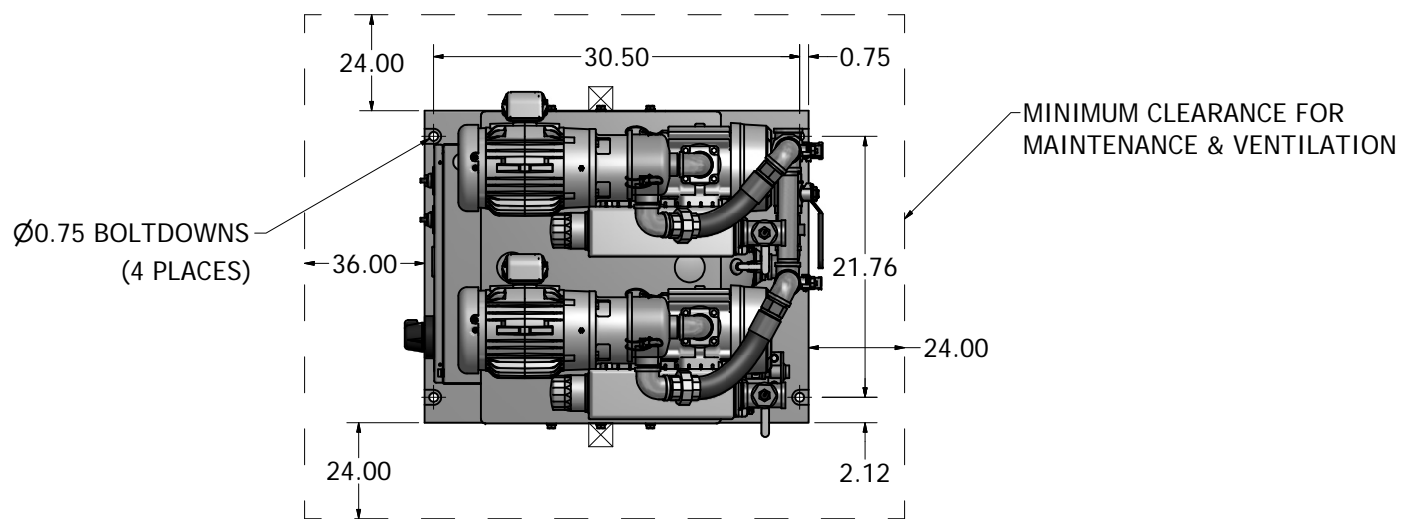

Revised: JOL	Date: 12/11/15	Drawn: JOL	Date: 07/13/15
INSPECTION CHECKLIST UNLESS OTHERWISE SPECIFIED:		UNLESS OTHERWISE SPECIFIED ALL DIMENSIONS ARE IN INCHES AND TOLERANCES ARE: XX ± 0.2 XXX ± 0.05	
ALL ITEMS MARKED BY ONE OF THE ABOVE SYMBOLS ARE TO BE INSPECTED		EQUIPMENT TO BE USED DURING RECEIVING INSPECTION SHALL BE PER QUALITY SYSTEM PROCEDURES	
Description: GENERAL ASSEMBLY DX 2HP LUBE VTM V 30G BASIC		Part Number: 4107 8553 37	
Sheet 1 of 1		Rev: 01	