

SINGLE POINT POWER WIRING ACCESS

ALARM WIRING ACCESS

ETHERNET WIRING ACCESS

SOURCE SHUTOFF VALVE

1-1/2" FNPT INLET CONNECTION

MAIN VACUUM GAUGE  
MAIN LINE VACUUM SWITCH

FROM HOSPITAL

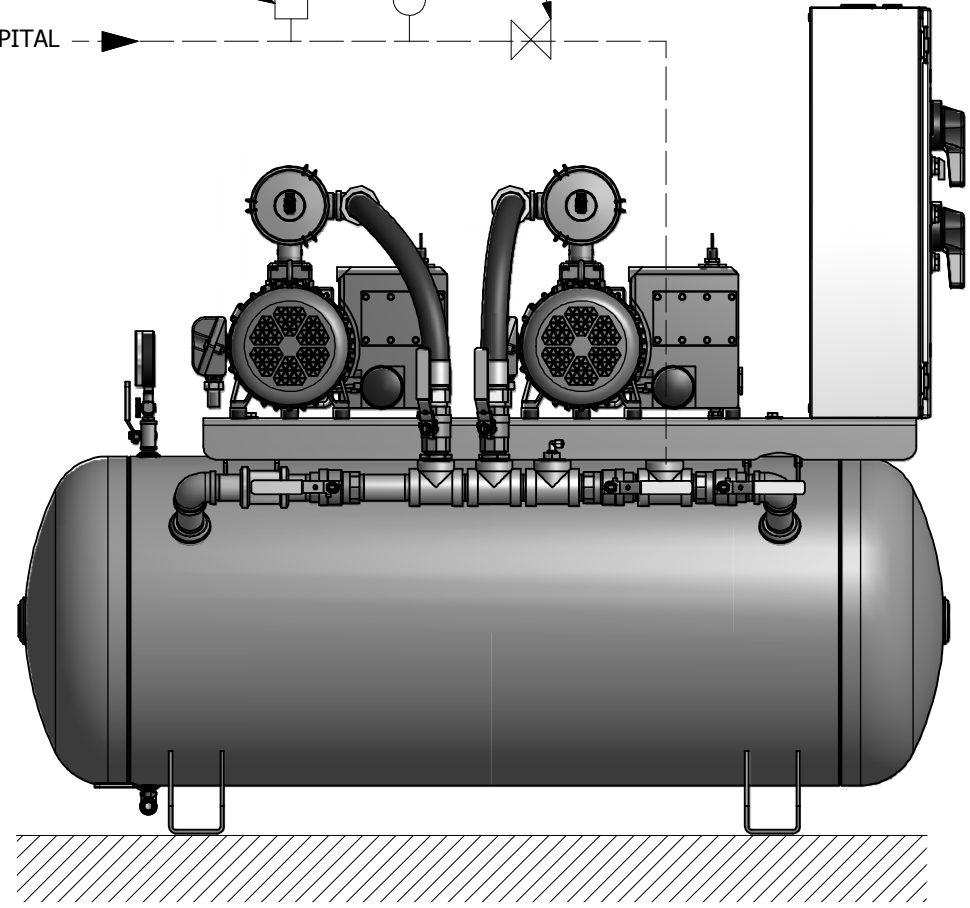

NO FOUNDATION OR INERTIA PAD IS REQUIRED  
(HOUSEKEEPING PAD IS OPTIONAL)

PIPE EXHAUST OUTSIDE,  
TURN DOWN AND SCREEN  
PER NFPA 99

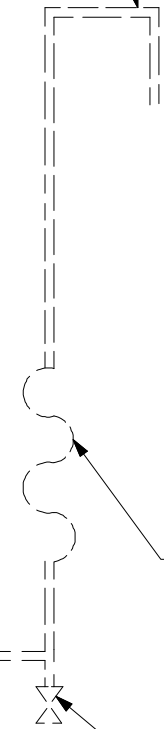

Notes:

1. ALL INTERCONNECTING PIPE AND FITTINGS SHALL BE INSTALLED BY THE CONTRACTOR.
2. ALL PIPING SHALL BE INSTALLED IN ACCORDANCE WITH NFPA 99, 2005 EDITION. PIPING LAYOUT IS DIAGRAMMATIC ONLY. FINAL ARRANGEMENT WILL BE SITE SPECIFIC. CONTRACTOR WILL BE RESPONSIBLE FOR FIELD VERIFICATION AND COORDINATING ACTUAL LOCATION WITH ALL OTHER TRADES.
3. CONTRACTOR SHALL VERIFY MOTOR VOLTAGE, PHASE, AND AMP RATINGS BEFORE STARTING ELECTRICAL INSTALLATION; AND MAKE CERTAIN THE VOLTAGE SUPPLIED BY THE HOSPITAL IS THE SAME.
4. THE ROOM REQUIRES DEDICATED MECHANICAL VENTILATION WITH AN ALLOWABLE TEMPERATURE VARIANCE OF 40° TO 105°F. (FOR HIGHER AMBIENTS, CONSULT FACTORY)
5. ELECTRICAL POWER SHALL BE SUPPLIED FROM THE EQUIPMENT SYSTEM BRANCH OF THE ESSENTIAL ELECTRICAL SYSTEM (EMERGENCY POWER).
6. EQUIPMENT, INSTALLATION, AND TESTING OF THE MEDICAL VACUUM SYSTEM SHALL COMPLY WITH NFPA 99, 2005 EDITION, AND ALL STATE AND LOCAL CODES OR ORDINANCES.
7. WIRE LAG & HIGH TEMP. ALARM REMOTE CONTACTS IN THIS CONTROL SYSTEM TO MASTER ALARM SYSTEM AS REQUIRED BY NFPA 99.
8. ALL ACCESSORIES, PIPE, AND FITTINGS, EXCEPT DISCHARGE FLEX HOSES, BEYOND INLET AND DISCHARGE PORTS ARE SUPPLIED AND INSTALLED BY OTHERS.
9. WHEN DETERMINING THE TOTAL PIPE LENGTH, ADD ALL THE STRAIGHT LENGTHS OF PIPE TOGETHER IN ADDITION TO THE NUMBER OF ELBOWS TIMES THE EFFECTIVE PIPE LENGTH FOR THAT PIPE SIZE. (SEE EQUIVALENT PIPE LENGTH TABLE BELOW.)

EXHAUST PIPE SIZE TABLE (SEE NOTE 9)			
UNIT SIZE	PIPE LENGTH		
	1.5 HP	0' - 250'	251' - 500'
	1.25" NPT	1.5" NPT	
UNIT SIZE	PIPE LENGTH		
	2 HP	0' - 250'	251' - 500'
	1.5" NPT	2.0" NPT	
UNIT SIZE	PIPE LENGTH		
	3 HP	0' - 100'	101' - 400'
	1.5" NPT	2.0" NPT	3.0" NPT
UNIT SIZE	PIPE LENGTH		
	5 HP	0' - 150'	151' - 500'
	2.0" NPT	3.0" NPT	

EFFECTIVE PIPE LENGTH TABLE FOR ELBOWS				
PIPE SIZE (IN)	1.25" NPT	1.5" NPT	2.0" NPT	3.0" NPT
EFFECTIVE PIPE LENGTH (FT)	3.4	4.0	4.9	7.9

(5HP DX, 120G RECEIVER SHOWN)

Revised:	Date:	Drawn: JEB	Date: 5/4/2011
		This drawing and the information contained herein remain the property of BeaconMedes and may not be used for other than the purpose for which it is loaned without the expressed written permission from BeaconMedes Engineering.	
Description: INSTALLATION DIAGRAM TANK MOUNT LUBE VAC BASIC 1.5-5HP DX		Part Number: 4107 8531 11 DN: HOP110549 Rev: 00	
Sheet 1 of 1		DO NOT SCALE THIS DOCUMENT	