

NOTES:

1. ALL INTERCONNECTING PIPE AND FITTINGS SHALL BE INSTALLED BY THE CONTRACTOR.
2. ALL PIPING SHALL BE INSTALLED IN ACCORDANCE WITH NFPA 99, 2005 EDITION. PIPING LAYOUT IS DIAGRAMMATIC ONLY. FINAL ARRANGEMENT WILL BE SITE SPECIFIC. CONTRACTOR WILL BE RESPONSIBLE FOR FIELD VERIFICATION AND COORDINATING ACTUAL LOCATION WITH ALL OTHER TRADES.
3. CONTRACTOR SHALL VERIFY MOTOR VOLTAGE, PHASE AND AMP RATINGS BEFORE STARTING ELECTRICAL INSTALLATION; AND MAKE CERTAIN THE VOLTAGE SUPPLIED BY THE HOSPITAL IS THE SAME.
4. THE ROOM REQUIRES DEDICATED MECHANICAL VENTILATION WITH AN ALLOWABLE TEMPERATURE VARIANCE OF 40° TO 105°F. (FOR HIGHER AMBIENTS, CONSULT FACTORY)
5. ELECTRICAL POWER SHALL BE SUPPLIED FROM THE EQUIPMENT SYSTEM BRANCH OF THE ESSENTIAL ELECTRICAL SYSTEM (EMERGENCY POWER).
6. EQUIPMENT, INSTALLATION, AND TESTING OF THE MEDICAL VACUUM SYSTEM SHALL COMPLY WITH NFPA 99, 2005 EDITION, AND ALL STATE AND LOCAL CODES OR ORDINANCES.
7. WIRE LAG PUMP RUNNING ALARM REMOTE CONTACTS IN THIS CONTROL SYSTEM TO MASTER ALARM SYSTEM AS REQUIRED BY NFPA 99.
8. ALL ACCESSORIES, PIPE AND FITTINGS, BEYOND INLET AND DISCHARGE PORTS ARE SUPPLIED AND INSTALLED BY OTHERS.
9. WHEN DETERMINING THE TOTAL PIPE LENGTH, ADD ALL THE STRAIGHT LENGTHS OF PIPE TOGETHER IN ADDITION TO THE NUMBER OF ELBOWS TIME THE EFFECTIVE PIPE LENGTH FOR THAT PIPE SIZE. (SEE EQUIVALENT PIPE LENGTH TABLE & EXAMPLE CALCULATION IN THE O&M MANUAL)

FOR INTAKE PIPE SIZING REFER TO STANDARD PRESSURE DROP TABLES. TOTAL PRESSURE DROP SHOULD BE LESS THAN 2" Hg AT A SYSTEM VACUUM LEVEL OF 15" Hg.

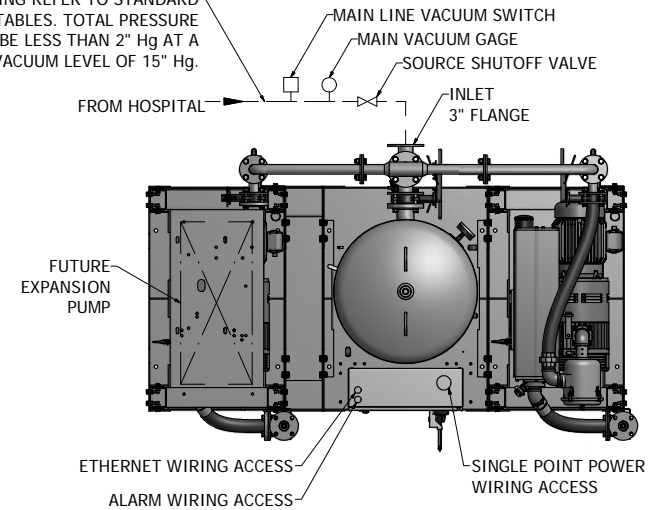

EXHAUST PIPE SIZE TABLE (SEE NOTE 9)			
UNIT SIZE	PIPE LENGTH		
QX 5	0-150'	151'-500'	
	3.00" NPT	4.00" NPT	
UNIT SIZE	PIPE LENGTH		
QX 7.5	0-100'	101'-400'	401'-500'
	3.00" NPT	4.00" NPT	5.00" NPT

EFFECTIVE PIPE LENGTH FOR ELBOWS			
PIPE SIZE (IN)	3.00" NPT	4.00" NPT	5.00" NPT
EFF. PIPE LENGTH (FT)	7.9	10	11.9

— — — — FIELD PIPING INLET  
 = = = = FIELD PIPING OUTLET

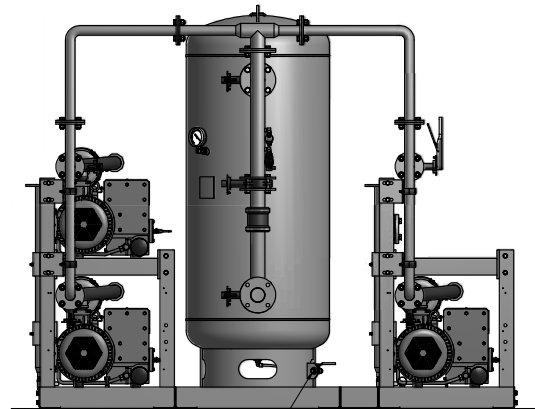

TANK DRAIN CONNECTION

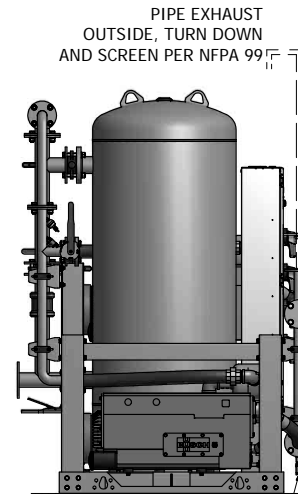

DRIP LEG VALVE  
(2 PLACES)

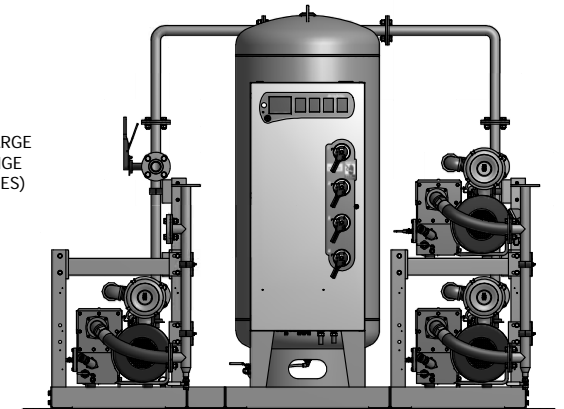

NO FOUNDATION OR INERTIA PAD IS REQUIRED  
(HOUSEKEEPING PAD IS OPTIONAL)

Revised: CCC	Date: 6/7/2013	Drawn: MDB	Scale: 1/13
<small>This drawing and the information contained therein remain the property of DragonMedes and may not be used for other than the purpose for which it is issued without the expressed written permission from DragonMedes Engineering.</small>			
Description: INSTALLATION DIAGRAM 5-7.5HP TX-X-QX LUBE VAC SPC		Drawing Number: 4107 8523 31	
Rev: USN130707		Rev: 01	
Sheet: 1 of 1		DO NOT SCALE THIS DRAWING	

(7.5HP WITH 200 GALLON RECEIVER SHOWN)