

Notes:

- DX MODULE W/ PANEL WEIGHT: 1,922 LBS  
DX MODULE WEIGHT: 1,746 LBS (INCLUDES FUTURE EXPANSION PUMP)  
200G TANK WEIGHT: 638 LBS
- ☒ INDICATES LIFTING POINT.
- DENOTES CENTER OF GRAVITY (INCLUDES FUTURE EXPANSION PUMP).

SYSTEM CONNECTIONS	
ID	DESCRIPTION
I	INLET LOCATION
D	DISCHARGE LOCATION
C	CONDENSATE DRAIN LOCATION
T	TANK DRAIN LOCATION

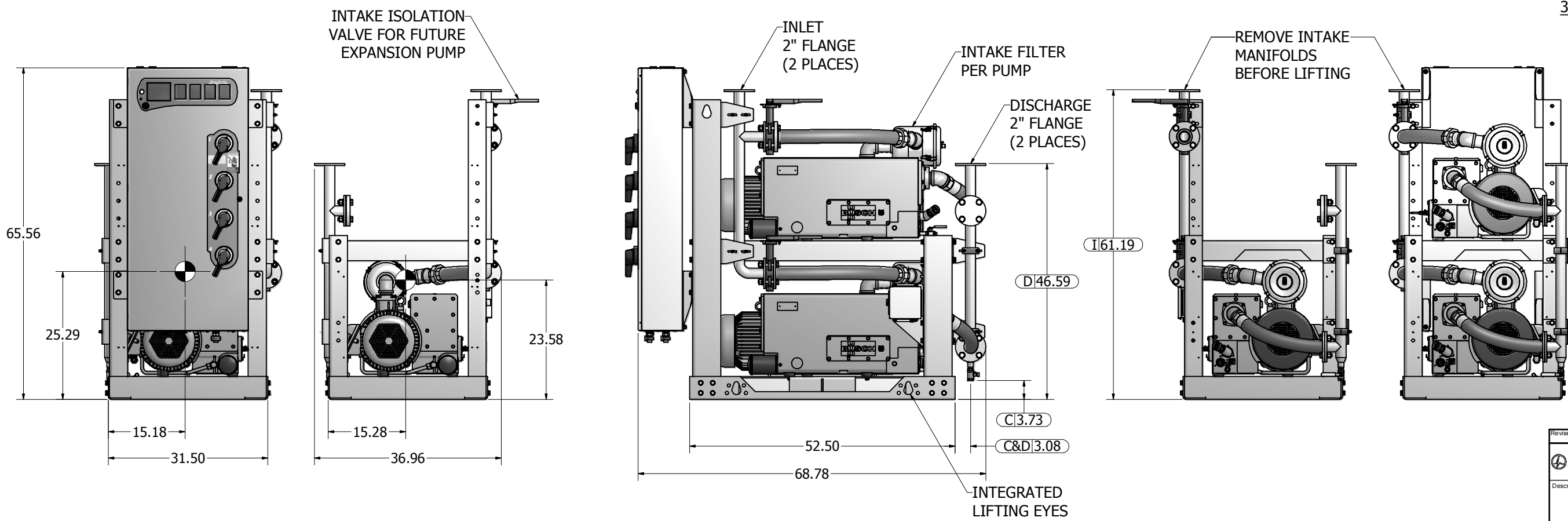
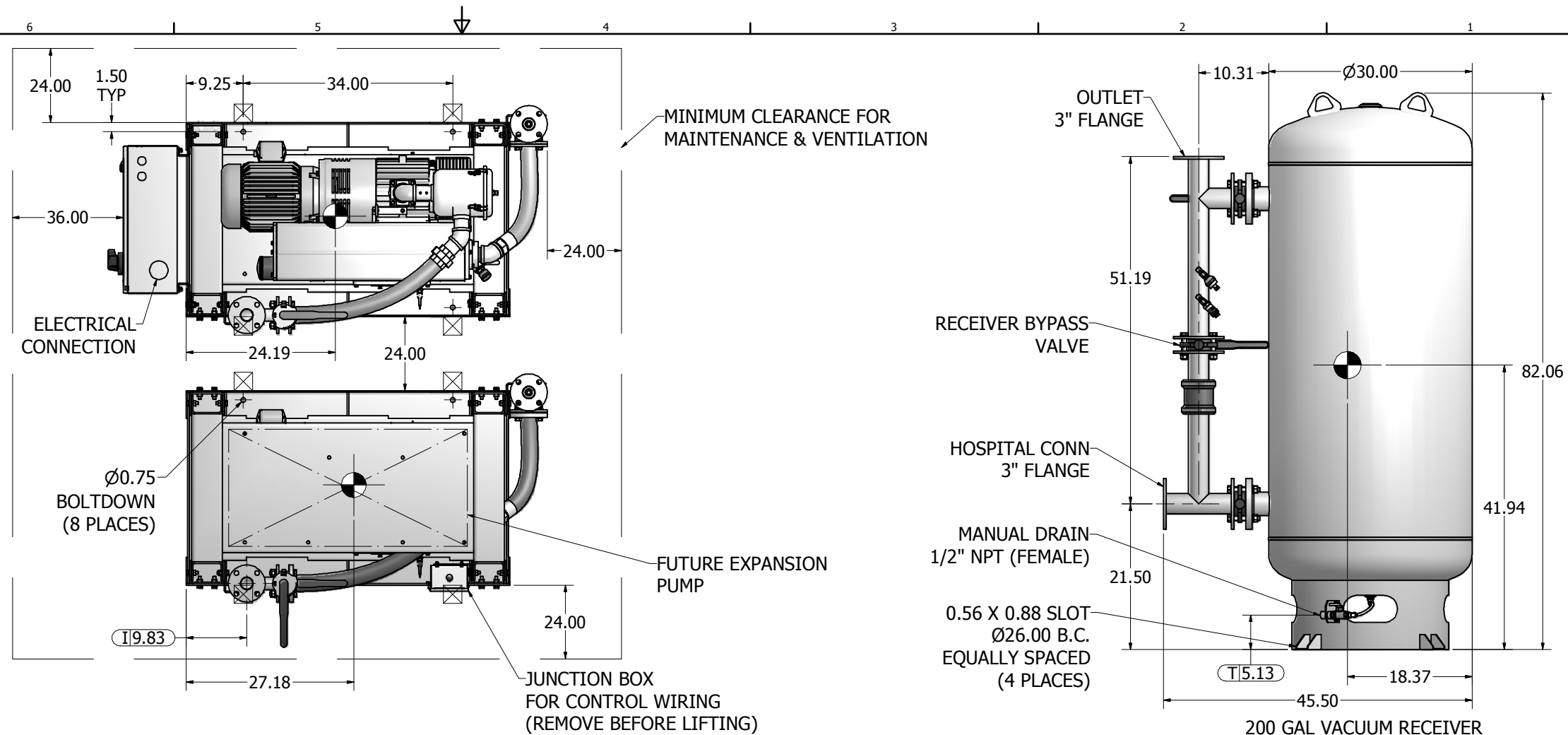

Revised:	Date:	Drawn: USNKW	Date: 11/12/2010
		This drawing and the information contained therein remain the property of BeaconMedes and may not be used for other than the purpose for which it is loaned without the expressed written permission from BeaconMedes Engineering.	
Description: GENERAL ASSEMBLY 10HP TX-EXP-QX LUBE VAC MOD 200G RECEIVER		Part Number: 4107 8522 78 DN: HOP100815 Rev: 00 Sheet 1 of 1	
Scale: 1/11		DO NOT SCALE THIS DOCUMENT	