

Notes:

- DX MODULE W/ PANEL WEIGHT: 1,473 LBS
DX MODULE WEIGHT: 1,307 LBS (INCLUDES FUTURE EXPANSION PUMP)
240G TANK WEIGHT: 713 LBS
- ☒ INDICATES LIFTING POINT.
- DENOTES CENTER OF GRAVITY (INCLUDES FUTURE EXPANSION PUMP).

SYSTEM CONNECTIONS	
ID	DESCRIPTION
I	INLET LOCATION
D	DISCHARGE LOCATION
C	CONDENSATE DRAIN LOCATION
T	TANK DRAIN

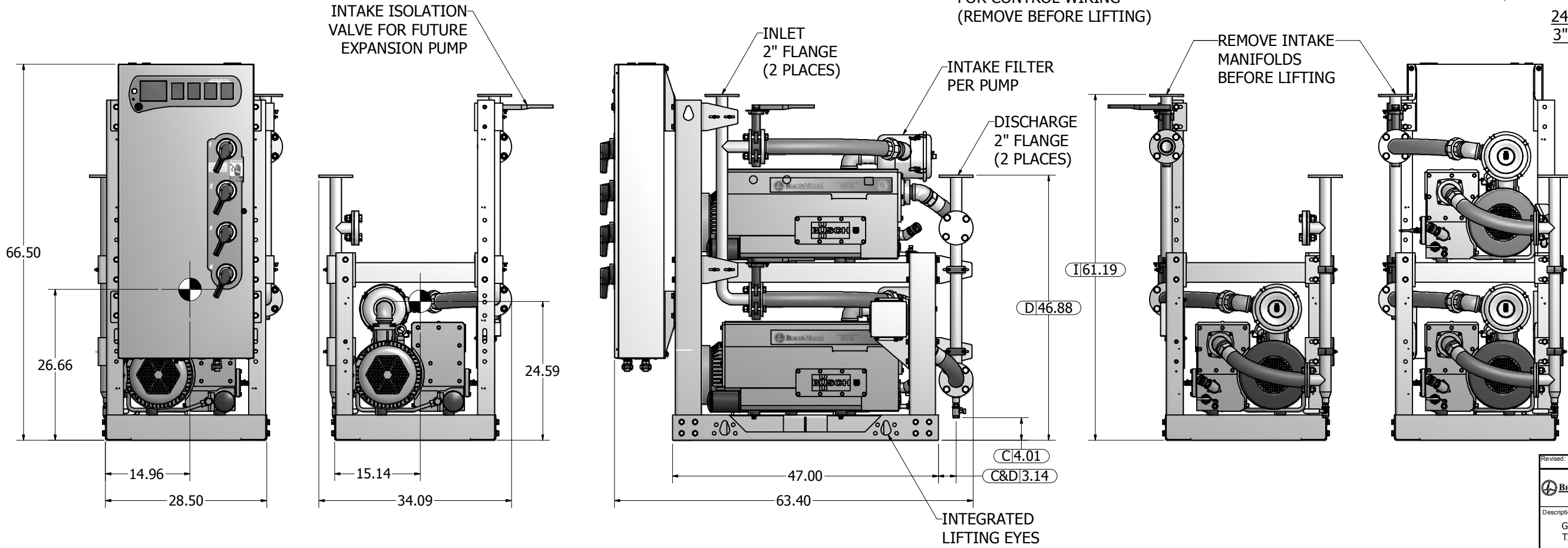
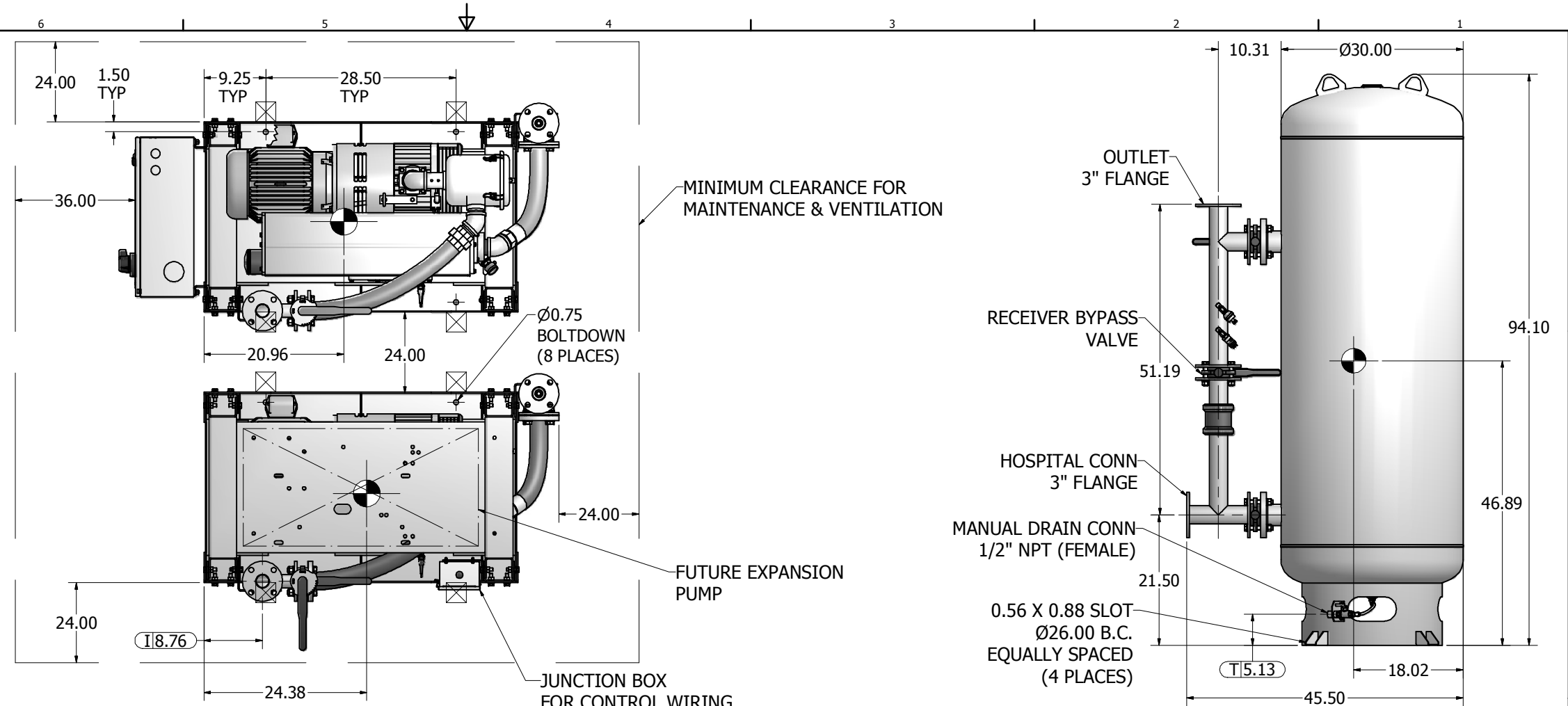

Revised:	Date:	Drawn:	Date:
		USNKW	11/12/2010
		This drawing and the information contained therein remain the property of BeaconMedes and may not be used for other than the purpose for which it is loaned without the expressed written permission from BeaconMedes Engineering.	
Description: GENERAL ASSEMBLY 7.5HP TX-EXP-QX LUBE VAC MOD 240G RECEIVER		Part Number: 4107 8522 77 DN: HOP100815 Rev: 00 Sheet 1 of 1	
		Scale: 1/10 D DO NOT SCALE THIS DOCUMENT	