

Notes:

- DX MODULE W/ PANEL WEIGHT: 1,140 LBS
DX MODULE WEIGHT: 928 LBS (INCLUDES FUTURE EXPANSION PUMP)
200G TANK WEIGHT: 638 LBS
- ⊠ INDICATES LIFTING POINT.
- DENOTES CENTER OF GRAVITY (INCLUDES FUTURE EXPANSION PUMP).

| SYSTEM CONNECTIONS | |
|--------------------|---------------------------|
| ID | DESCRIPTION |
| I | INLET LOCATION |
| D | DISCHARGE LOCATION |
| C | CONDENSATE DRAIN LOCATION |
| T | TANK DRAIN |

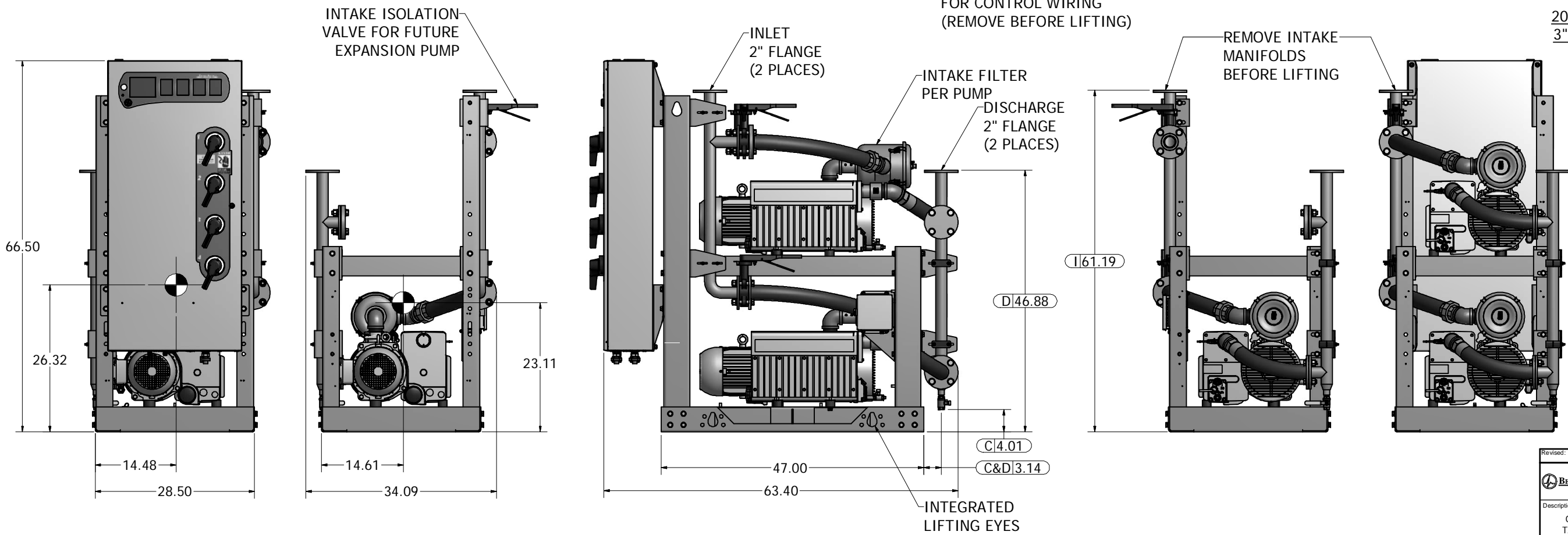
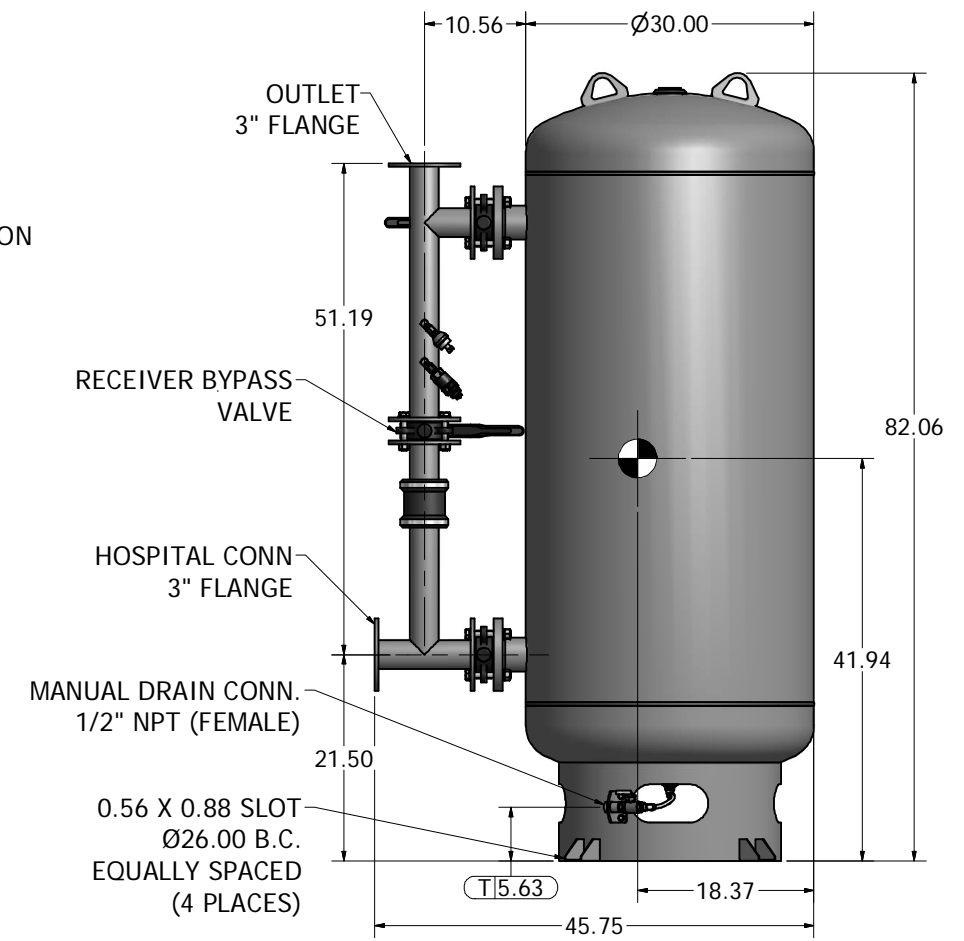
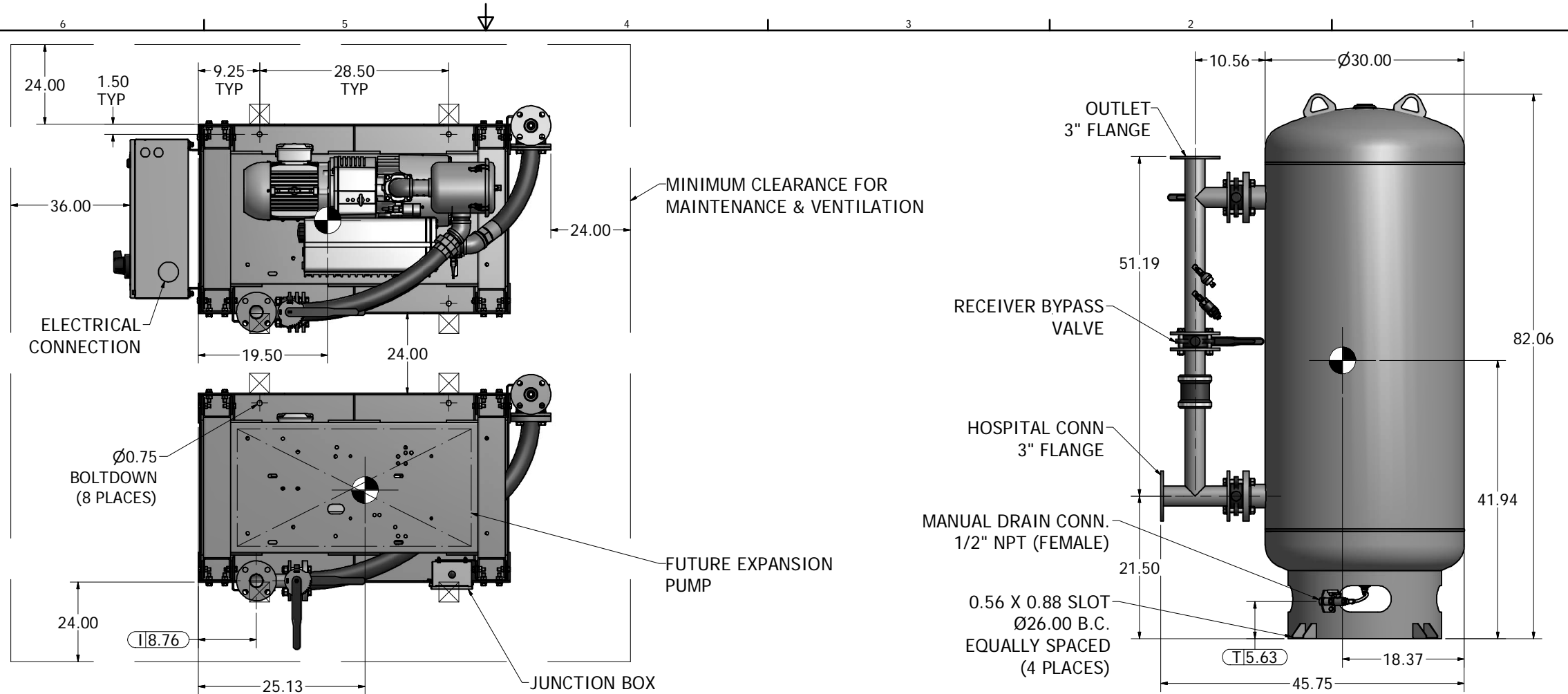

| | | | |
|---|----------------|--|------------------|
| Revised: GTM | Date: 7/9/2015 | Drawn: USNKKW | Date: 11/12/2010 |
| | | This drawing and the information contained therein remain the property of BeaconMedes and may not be used for other than the purpose for which it is loaned without the expressed written permission from BeaconMedes Engineering. | |
| Description: GENERAL ASSEMBLY 5HP TX-EXP-QX LUBE VAC MOD 200G RECEIVER | | Part Number: 4107 8522 74 DN: HOP150676 Rev: 01 Sheet 1 of 1 | |
| Scale: 1/10 | | DO NOT SCALE THIS DOCUMENT | |