

- Notes:
- TX MODULE WEIGHT: 2,070 LBS (INCLUDES FUTURE EXPANSION PUMP)
240G TANK WEIGHT: 713 LBS
 - ☒ INDICATES LIFTING POINT.
 - DENOTES CENTER OF GRAVITY (INCLUDES FUTURE EXPANSION PUMP).

SYSTEM CONNECTIONS	
ID	DESCRIPTION
I	INLET LOCATION
D	DISCHARGE LOCATION
C	CONDENSATE DRAIN LOCATION
T	TANK DRAIN LOCATION

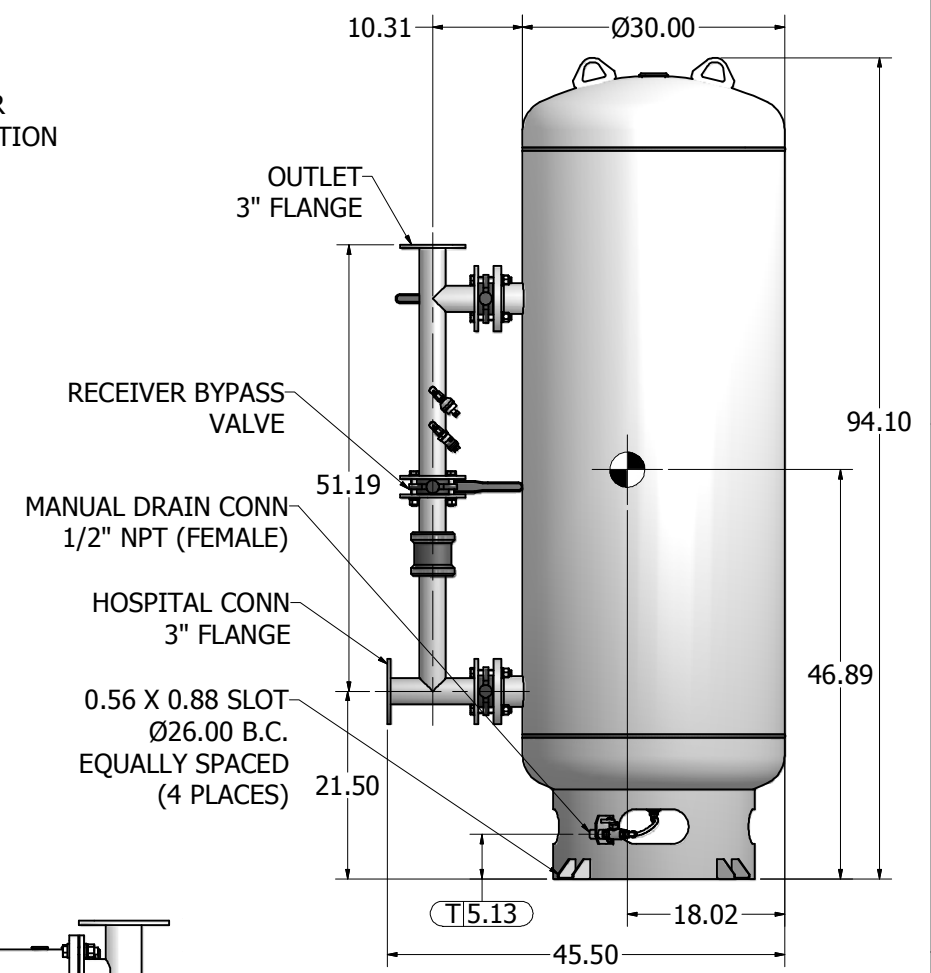

240 GAL VACUUM RECEIVER
3" FLANGED CONNECTIONS
(NTS)

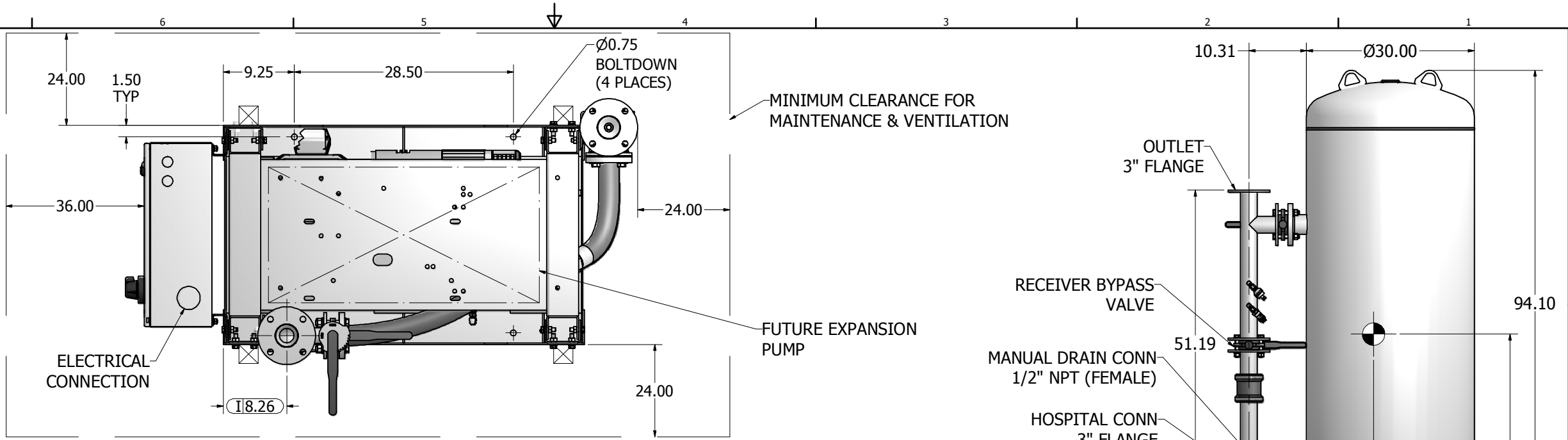
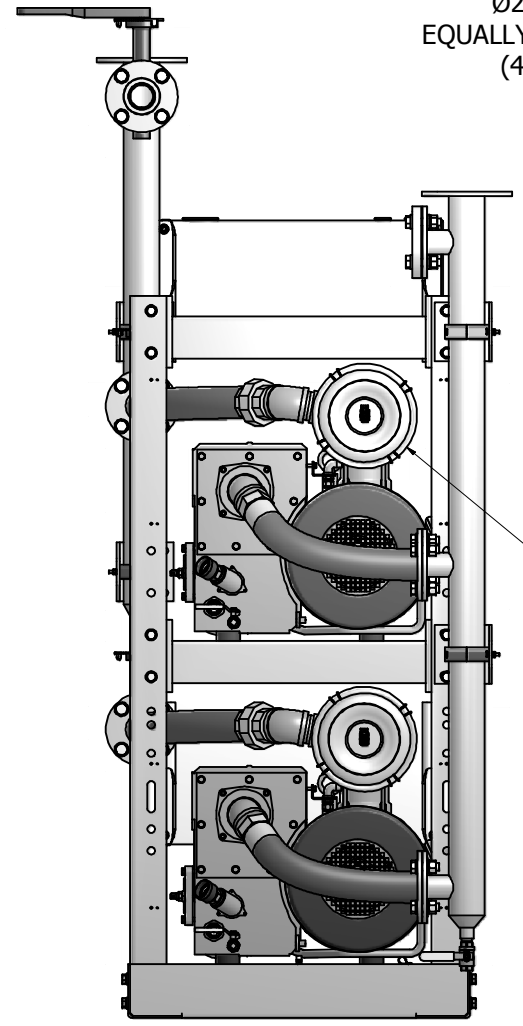
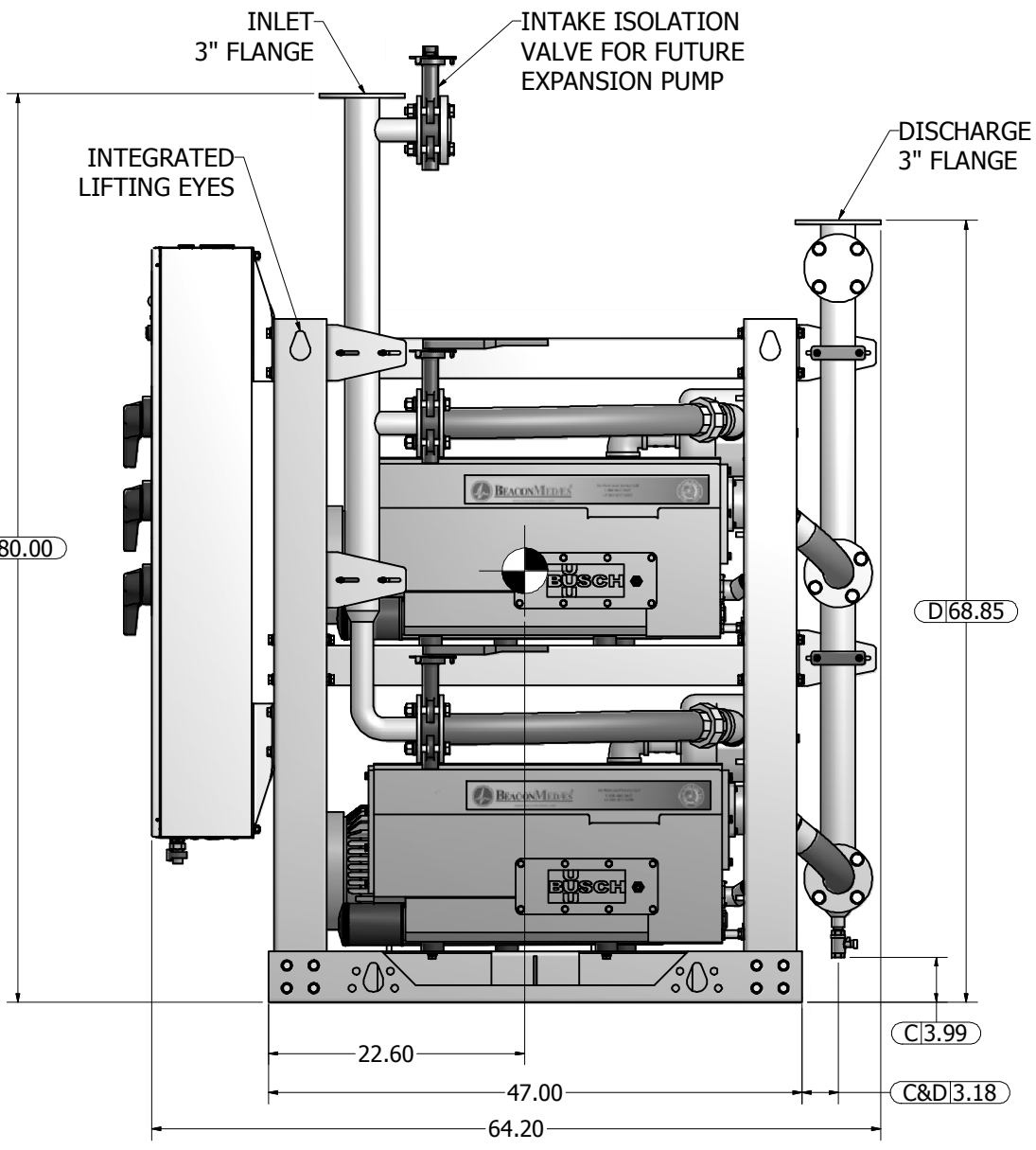
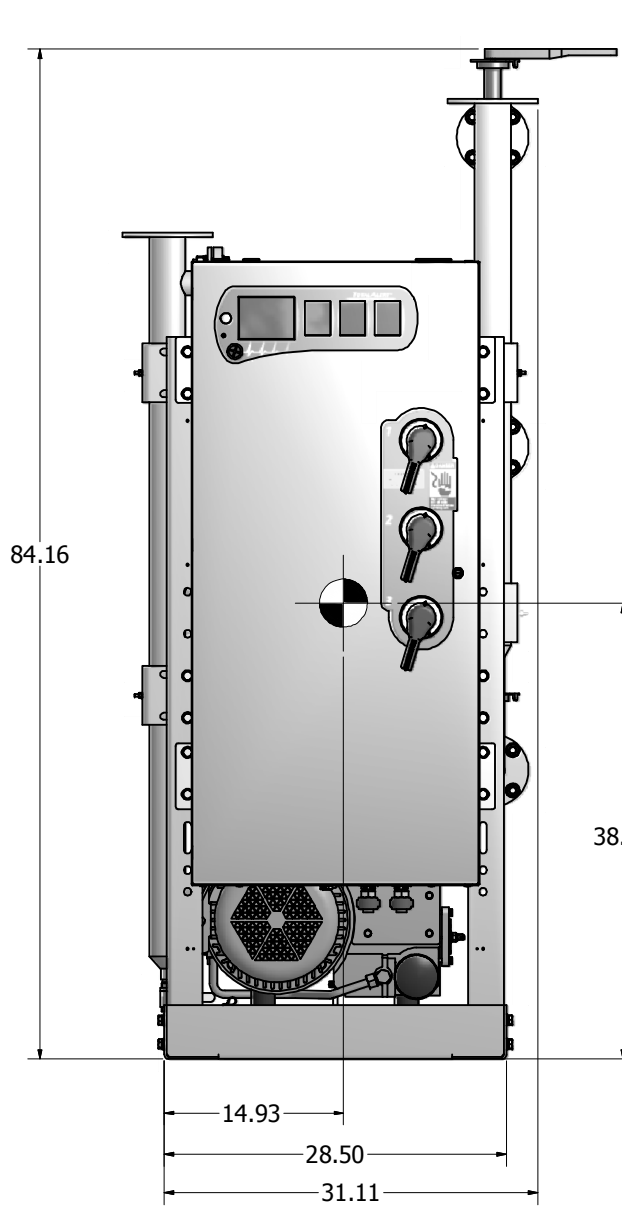

Revised:	Date:	Drawn: USNKW	Date: 11/11/2010
		This drawing and the information contained therein remain the property of BeaconMedies and may not be used for other than the purpose for which it is loaned without the expressed written permission from BeaconMedies Engineering.	
Description: GENERAL ASSEMBLY 7.5HP DX-EXT-TX LUBE VAC MOD 240G RECEIVER		Part Number: 4107 8522 71 Rev: 00 HOP100815 Sheet 1 of 1 DO NOT SCALE THIS DOCUMENT	