

Notes:

- DX MODULE W/ PANEL WEIGHT: 1,922 LBS
DX MODULE WEIGHT: 1,746 LBS
240G TANK WEIGHT: 713 LBS

2. INDICATES LIFTING POINT.

3. DENOTES CENTER OF GRAVITY.

| SYSTEM CONNECTIONS | |
|--------------------|---------------------------|
| ID | DESCRIPTION |
| I | INLET LOCATION |
| D | DISCHARGE LOCATION |
| C | CONDENSATE DRAIN LOCATION |
| T | TANK DRAIN LOCATION |

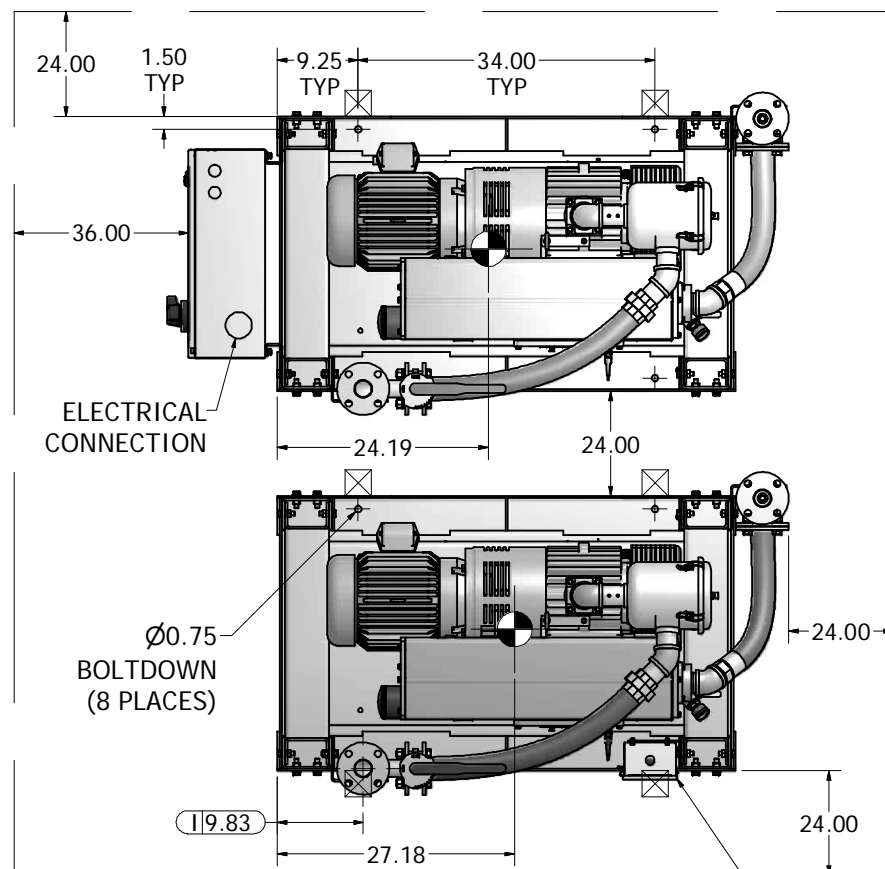

MINIMUM CLEARANCE FOR MAINTENANCE & VENTILATION

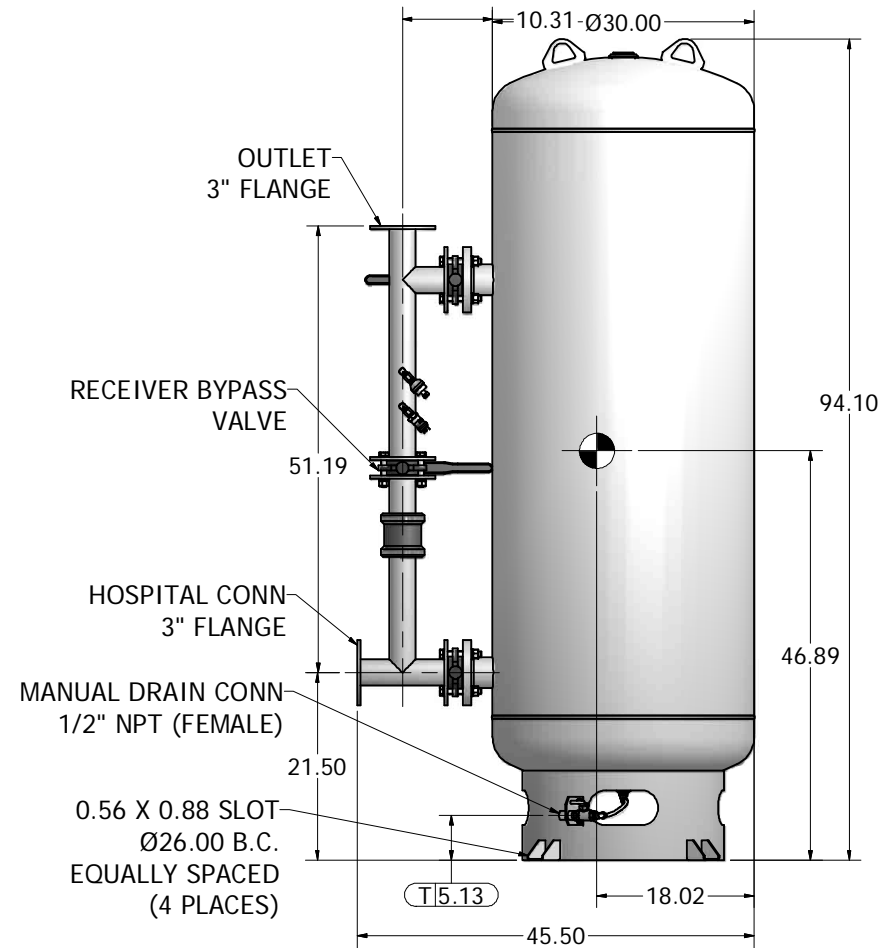

240 GAL VACUUM RECEIVER
3" FLANGED CONNECTIONS
(NTS)

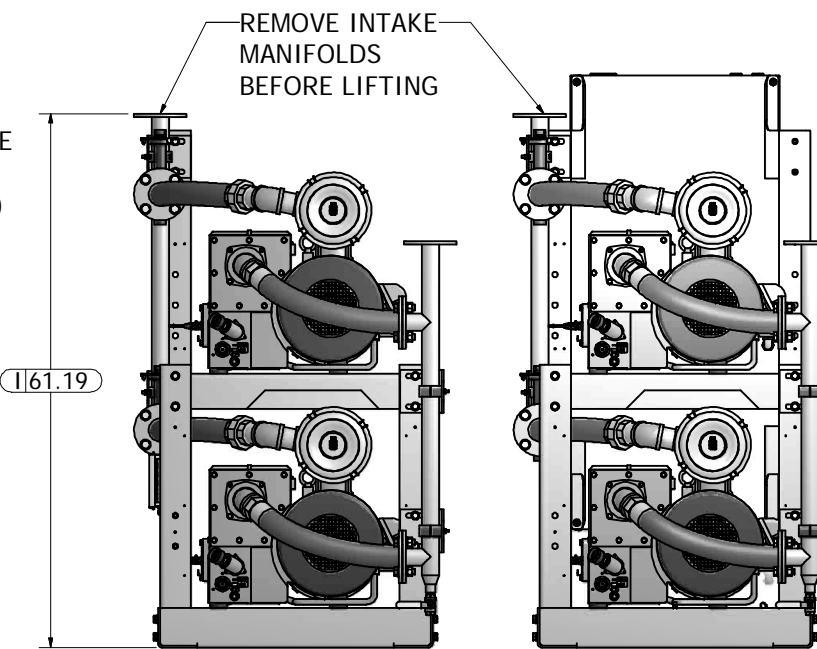
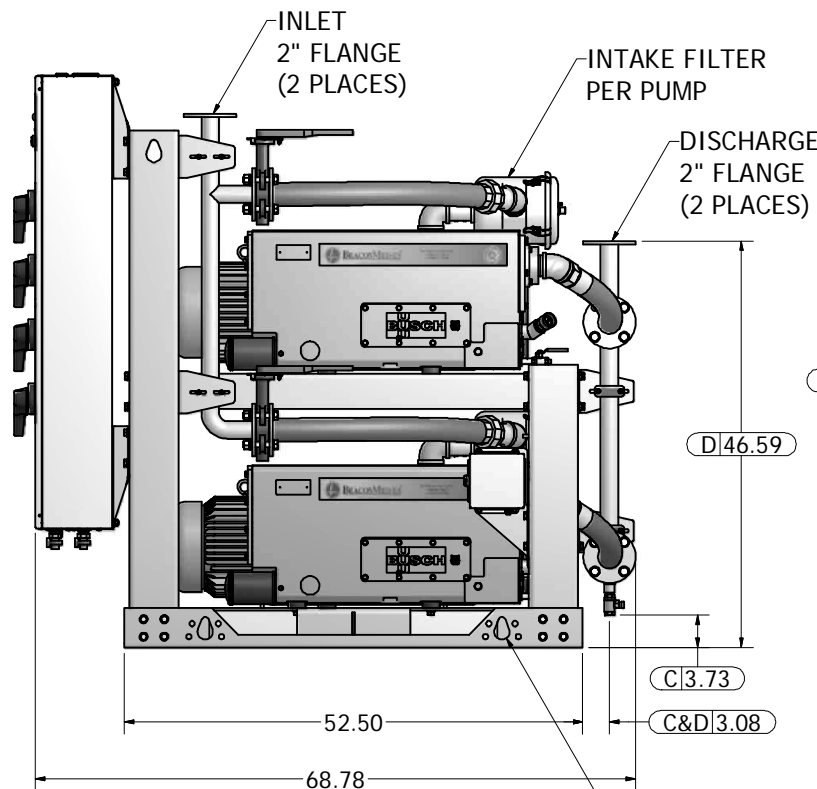
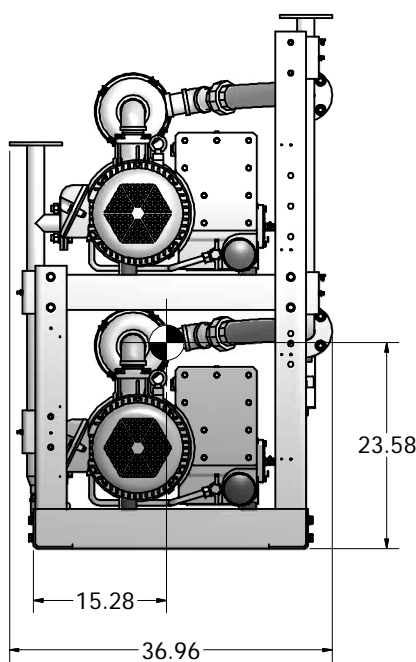
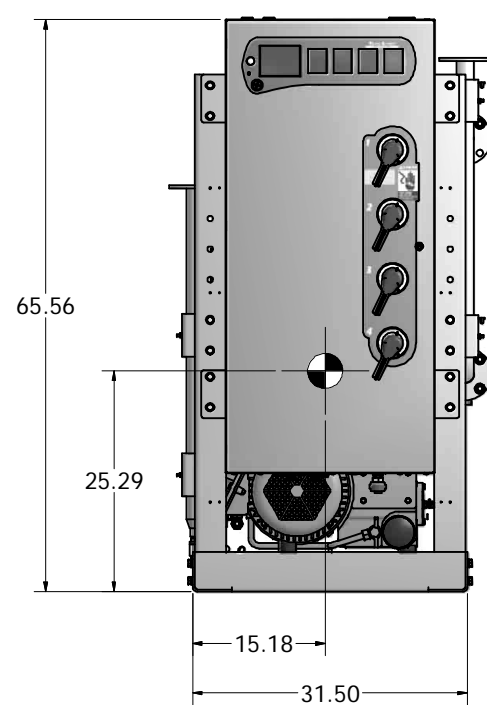

| | | | |
|---|-------|--|------------------|
| Revised: | Date: | Drawn: USNKW | Date: 10/27/2010 |
| | | This drawing and the information contained therein remain the property of BeaconMedes and may not be used for other than the purpose for which it is loaned without the expressed written permission from BeaconMedes Engineering. | |
| Description: | | Part Number: 4107 8522 26 | |
| GENERAL ASSEMBLY 10HP OX LUBE VAC MOD 240G RECEIVER | | DN: HOP100727 | Rev: 00 |
| Sheet 1 of 1 | | DO NOT SCALE THIS DOCUMENT | |