

Notes:

- DX MODULE W/ PANEL WEIGHT: 1,922 LBS  
DX MODULE WEIGHT: 1,746 LBS  
200G TANK WEIGHT: 638 LBS

2.  INDICATES LIFTING POINT.

3.  DENOTES CENTER OF GRAVITY.

SYSTEM CONNECTIONS	
ID	DESCRIPTION
I	INLET LOCATION
D	DISCHARGE LOCATION
C	CONDENSATE DRAIN LOCATION
T	TANK DRAIN LOCATION

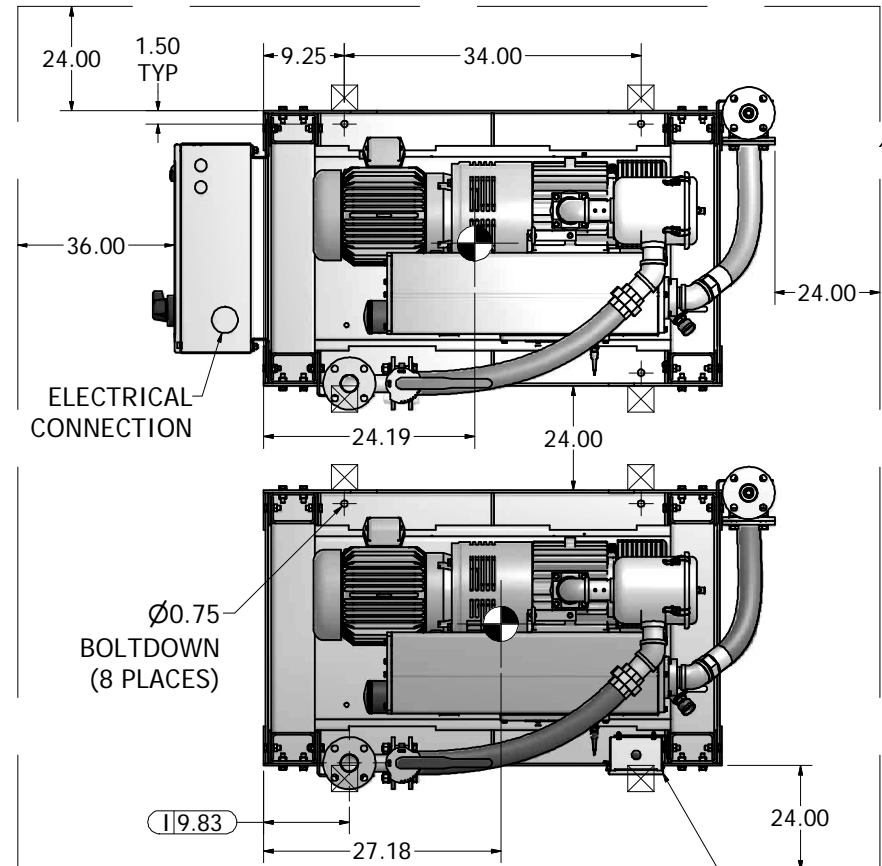

MINIMUM CLEARANCE FOR MAINTENANCE & VENTILATION

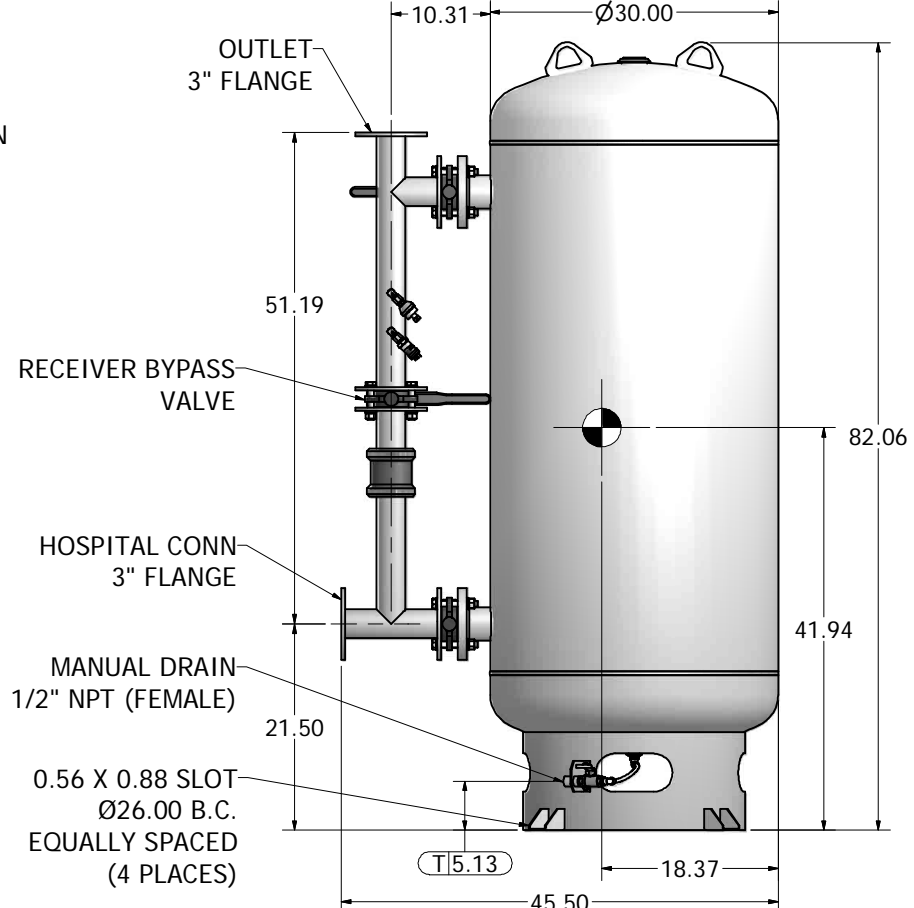

200 GAL VACUUM RECEIVER  
3" FLANGED CONNECTIONS  
(SCALE 1:10)

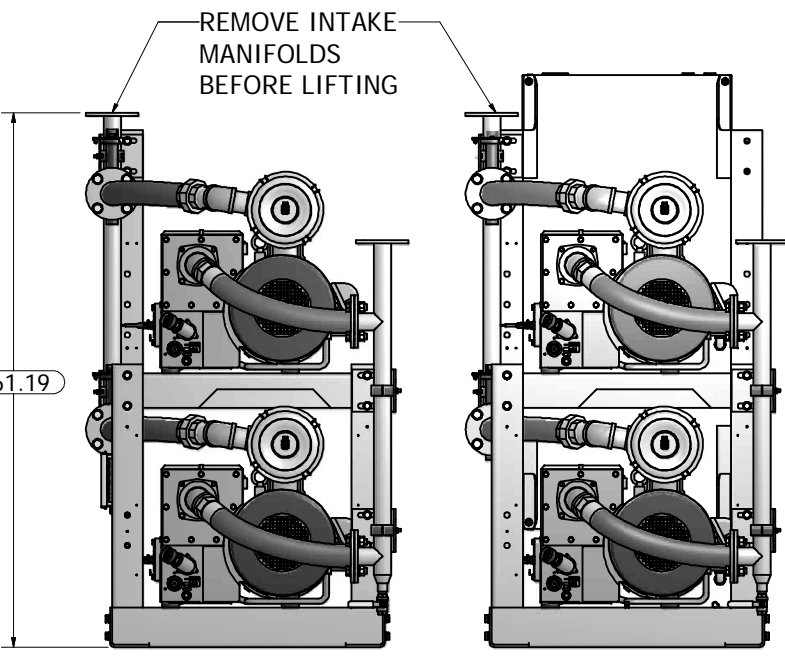
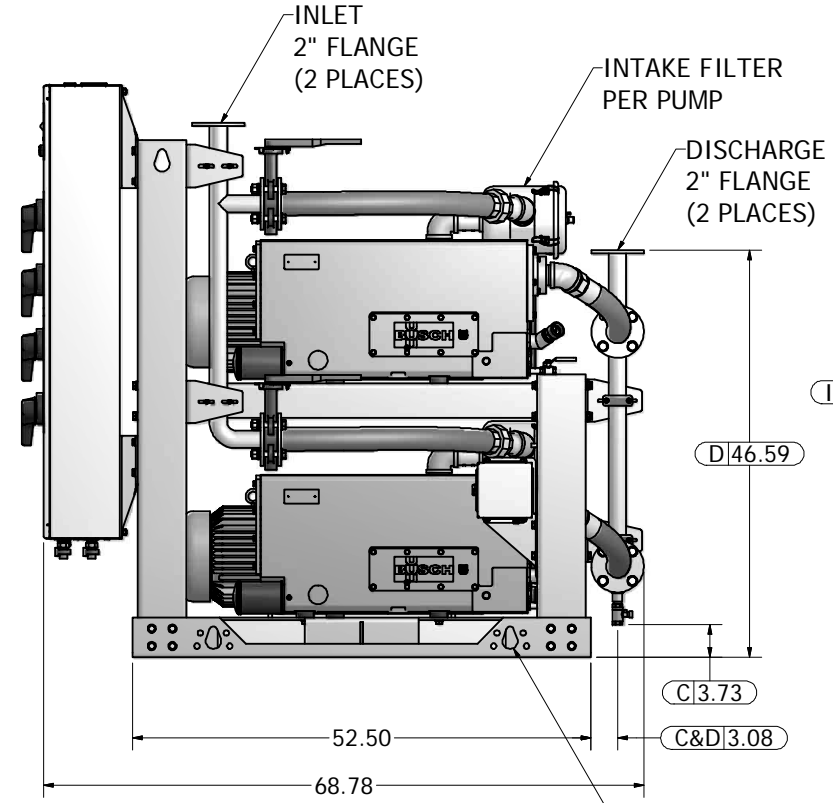
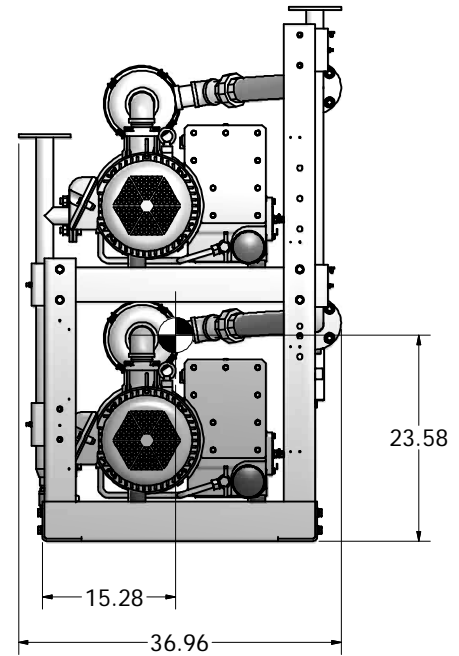
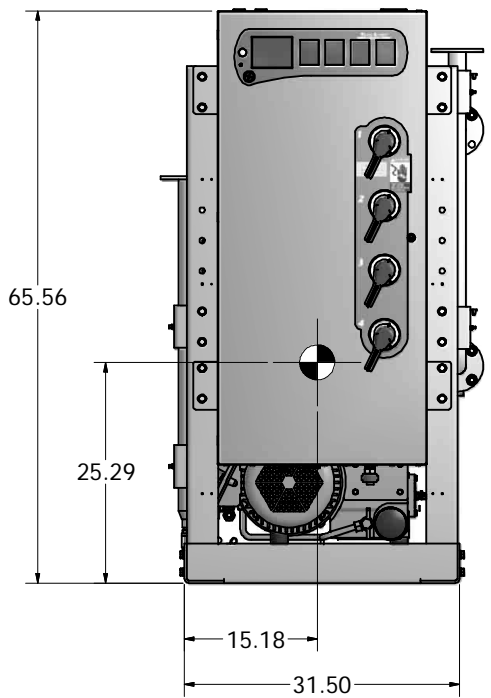

Revised:	Date:	Drawn:	Date:
		USNKW	10/27/2010
		This drawing and the information contained therein remain the property of BeaconMedes and may not be used for other than the purpose for which it is loaned without the expressed written permission from BeaconMedes Engineering.	
Description:		Part Number:	
GENERAL ASSEMBLY 10HP OX LUBE VAC MOD 200G RECEIVER		4107 8522 25	
DN:	HOP100727	Rev:	00
Sheet	1 of 1	DO NOT SCALE THIS DOCUMENT	