

Notes:

- DX MODULE W/ PANEL WEIGHT: 1,140 LBS  
DX MODULE WEIGHT: 928 LBS  
240G TANK WEIGHT: 713 LBS

2. INDICATES LIFTING POINT.

3. DENOTES CENTER OF GRAVITY.

SYSTEM CONNECTIONS	
ID	DESCRIPTION
I	INLET LOCATION
D	DISCHARGE LOCATION
C	CONDENSATE DRAIN LOCATION
T	TANK DRAIN

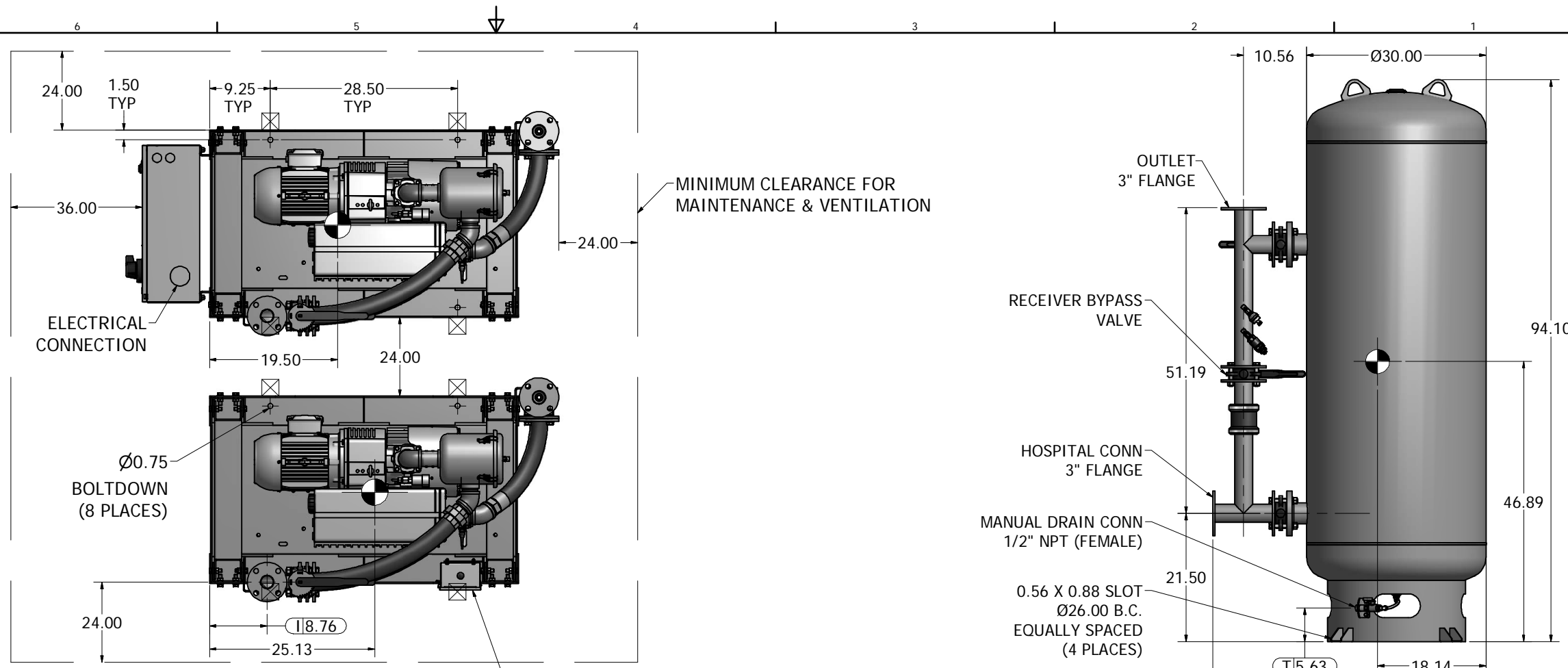

**240 GAL VACUUM RECEIVER**  
**3" FLANGED CONNECTIONS**  
(NTS)

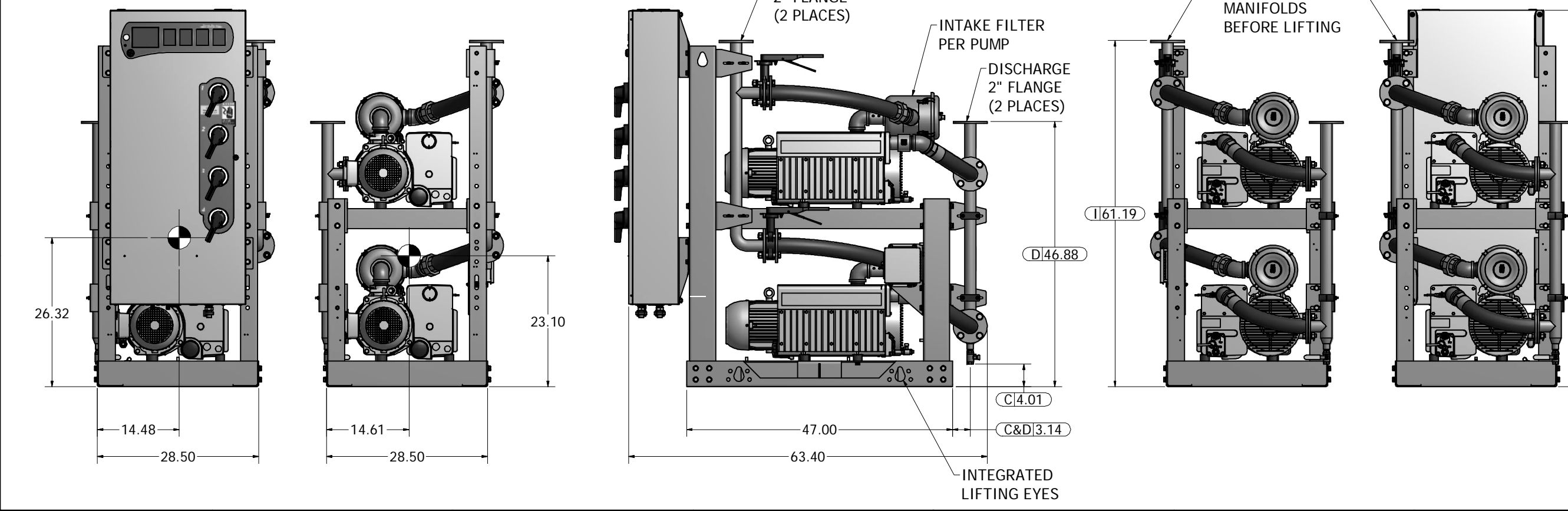

Revised: GTM	Date: 7/10/2015	Drawn: USNKW	Date: 10/26/2010
		This drawing and the information contained therein remain the property of BeaconMedes and may not be used for other than the purpose for which it is loaned without the expressed written permission from BeaconMedes Engineering.	
Description: GENERAL ASSEMBLY 5HP OX LUBE VAC MOD 240G RECEIVER		Part Number: 4107 8522 22	Scale: 1/10
Sheet 1 of 1		Rev: 01	DO NOT SCALE THIS DOCUMENT