

Notes:

1. DX MODULE WEIGHT: 1,868 LBS
200G TANK WEIGHT: 618 LBS
2. INDICATES LIFTING POINT.
3. DENOTES CENTER OF GRAVITY.

SYSTEM CONNECTIONS	
ID	DESCRIPTION
I	INLET LOCATION
D	DISCHARGE LOCATION
C	CONDENSATE DRAIN LOCATION
T	TANK DRAIN

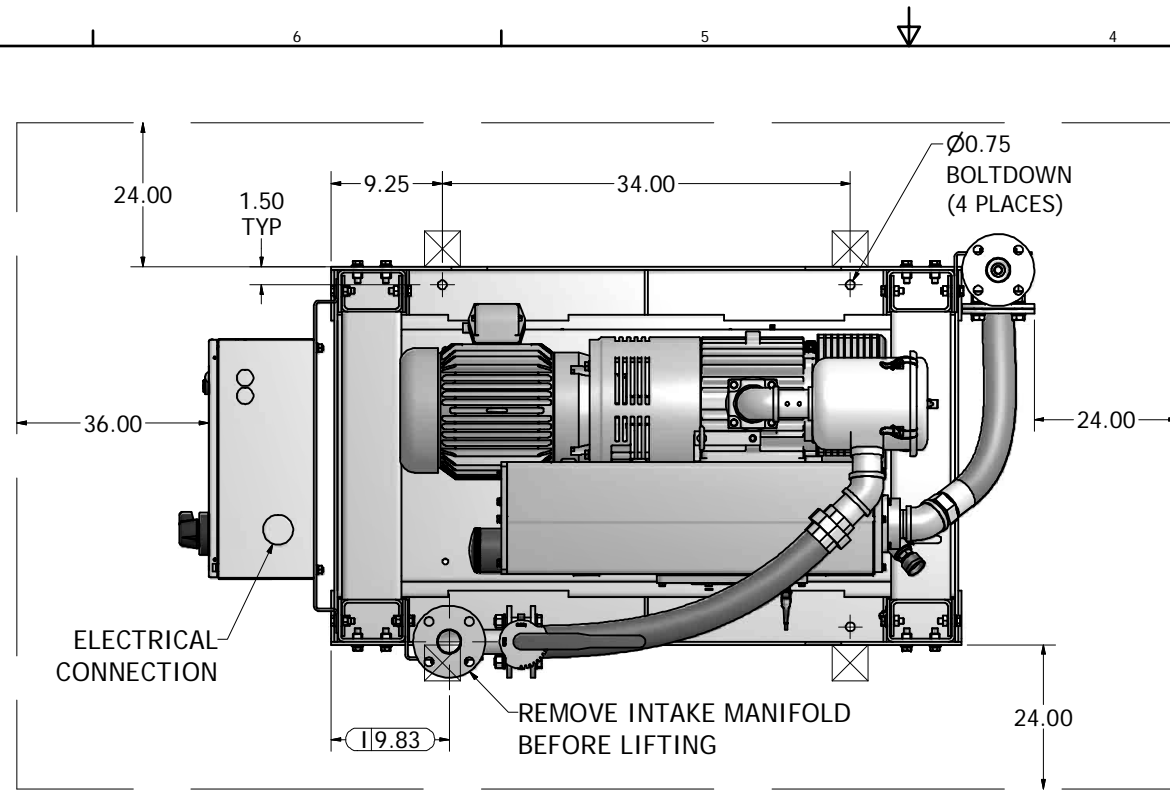

MINIMUM CLEARANCE FOR MAINTENANCE & VENTILATION

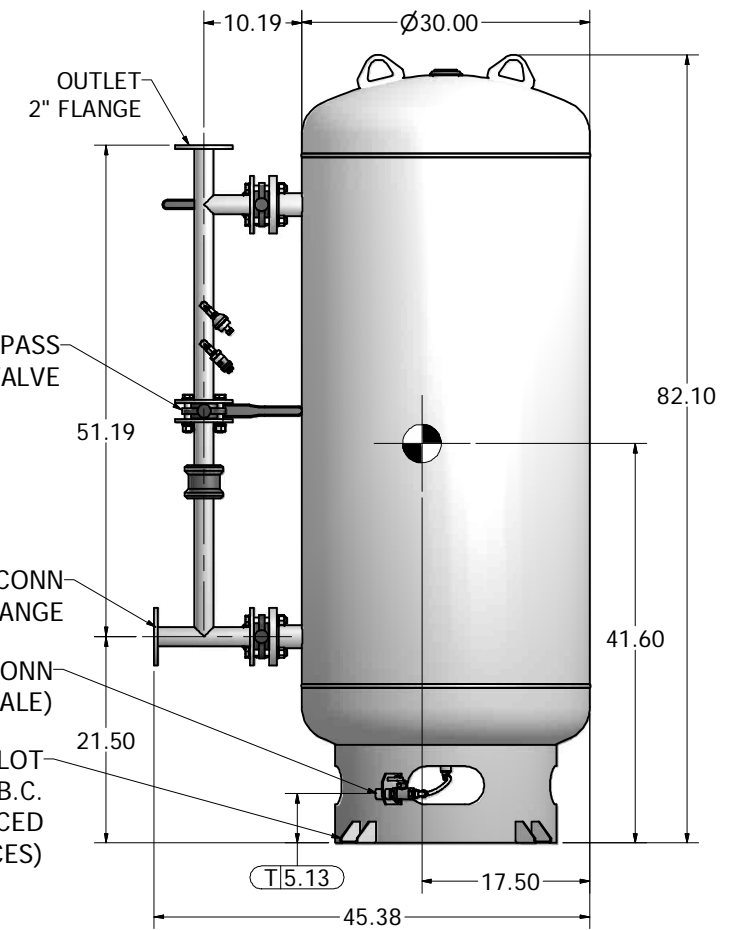

200 GAL VACUUM RECEIVER
2" FLANGED CONNECTIONS
(SCALE 1:10)

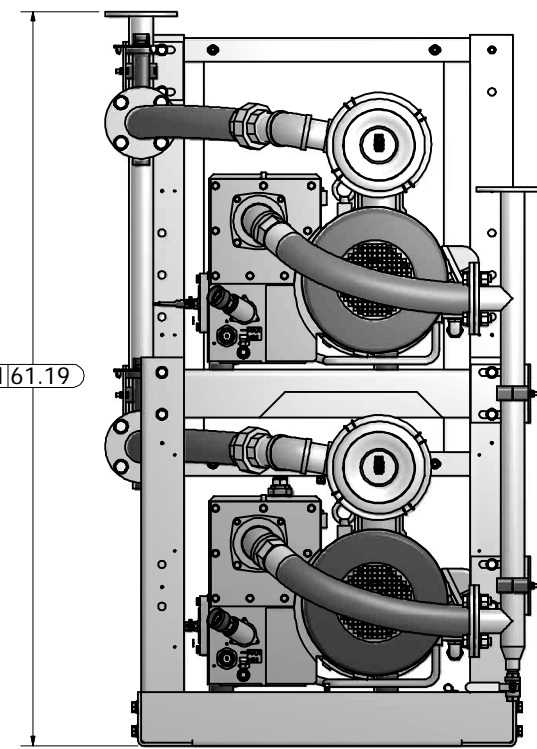
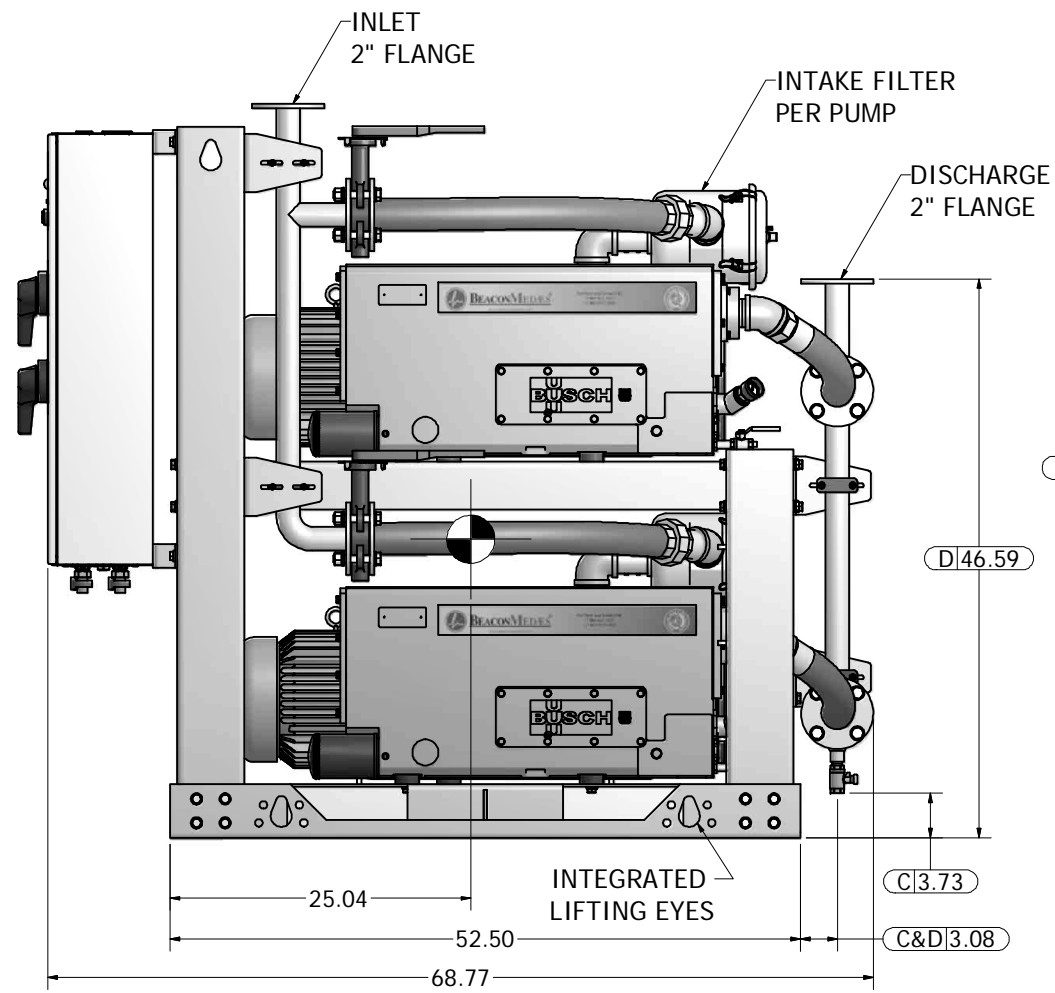
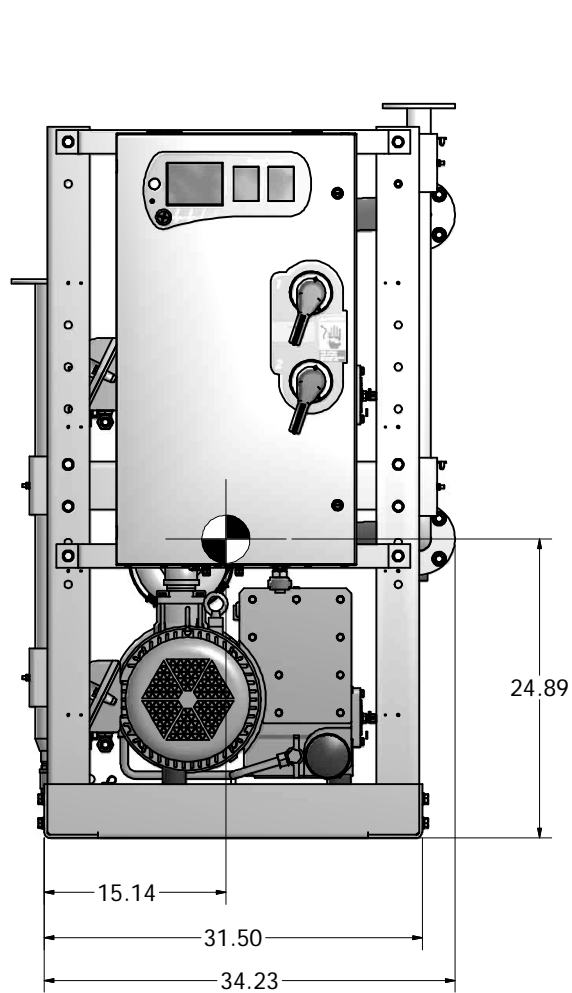

Revised:	Date:	Drawn: USNKW	Date: 10/21/2010
		This drawing and the information contained therein remain the property of BeaconMedes and may not be used for other than the purpose for which it is loaned without the expressed written permission from BeaconMedes Engineering.	
Description:		Part Number: 4107 8522 12	
GENERAL ASSEMBLY 10HP DX LUBE VAC MOD 200G RECEIVER		DN: HOP100727	Rev: 00
Sheet 1 of 1		DO NOT SCALE THIS DOCUMENT	