

Notes:

- DX MODULE WEIGHT: 1,868 LBS
120G TANK WEIGHT: 393 LBS
- ⊠ INDICATES LIFTING POINT.
- DENOTES CENTER OF GRAVITY.

SYSTEM CONNECTIONS	
ID	DESCRIPTION
I	INLET LOCATION
D	DISCHARGE LOCATION
C	CONDENSATE DRAIN LOCATION
T	TANK DRAIN

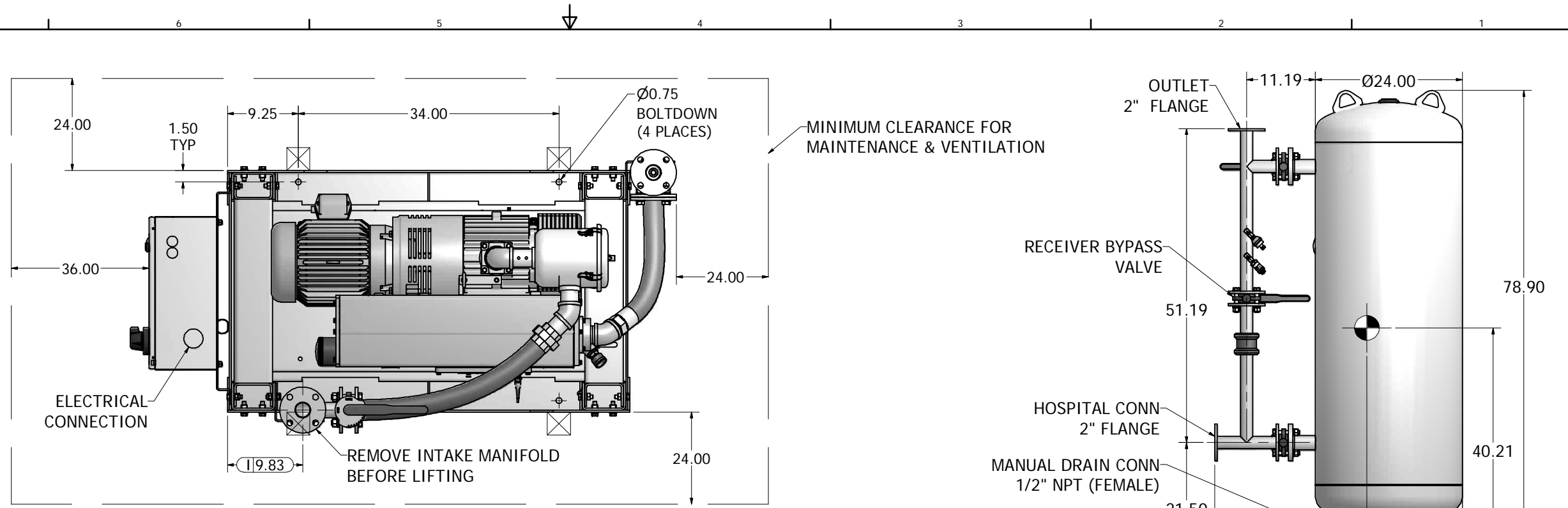

120 GAL VACUUM RECEIVER
2\"/>

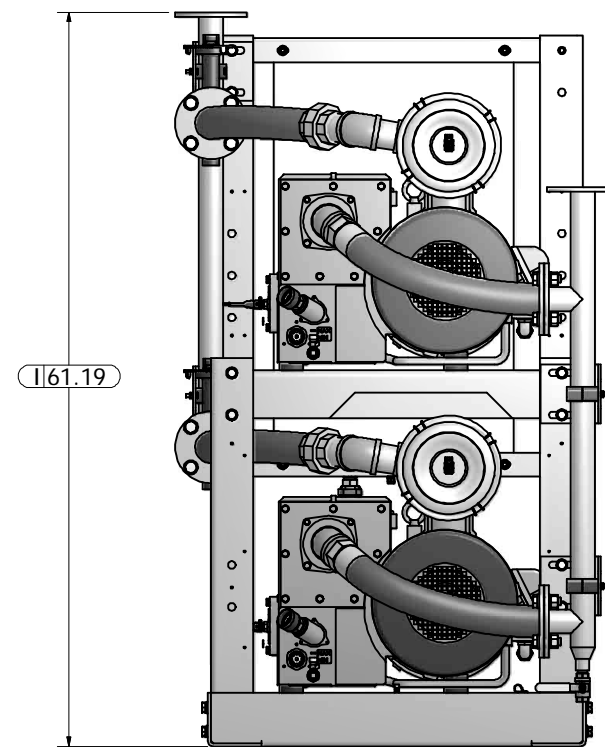
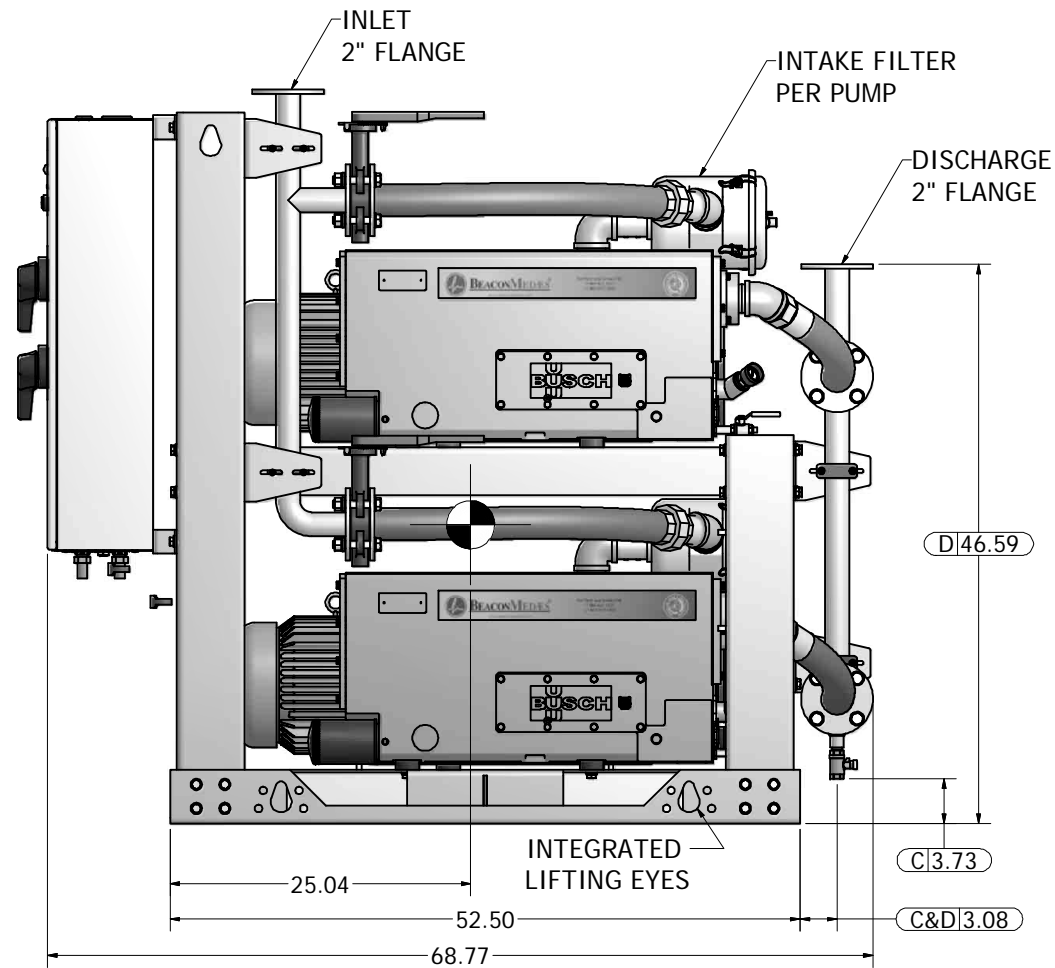
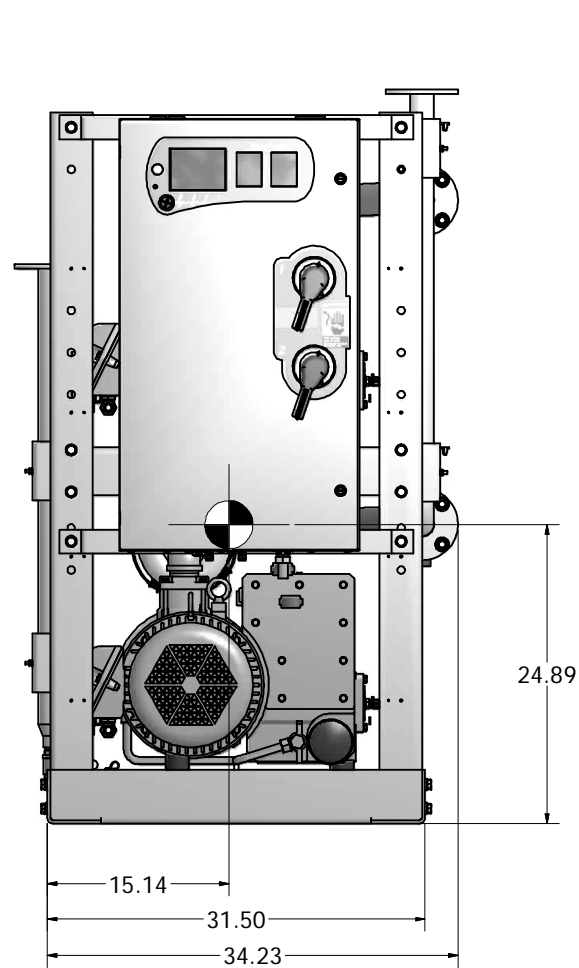

Revised:	Date:	Drawn:	Date:
		USNKW	10/21/2010
		This drawing and the information contained therein remain the property of BeaconMedes and may not be used for other than the purpose for which it is loaned without the expressed written permission from BeaconMedes Engineering.	
Description: GENERAL ASSEMBLY 10HP DX LUBE VAC MOD 120G RECEIVER		Drawing Number: 4107 8522 11	Scale: 1/8 D
Sheet 1 of 1		DN: HOP100727	Rev: 00
		DO NOT SCALE THIS DOCUMENT	