

Notes:

- DX MODULE WEIGHT: 1,419 LBS
240G TANK WEIGHT: 693 LBS
- ⊠ INDICATES LIFTING POINT.
- DENOTES CENTER OF GRAVITY.

SYSTEM CONNECTIONS	
ID	DESCRIPTION
I	INLET LOCATION
D	DISCHARGE LOCATION
C	CONDENSATE DRAIN LOCATION
T	TANK DRAIN

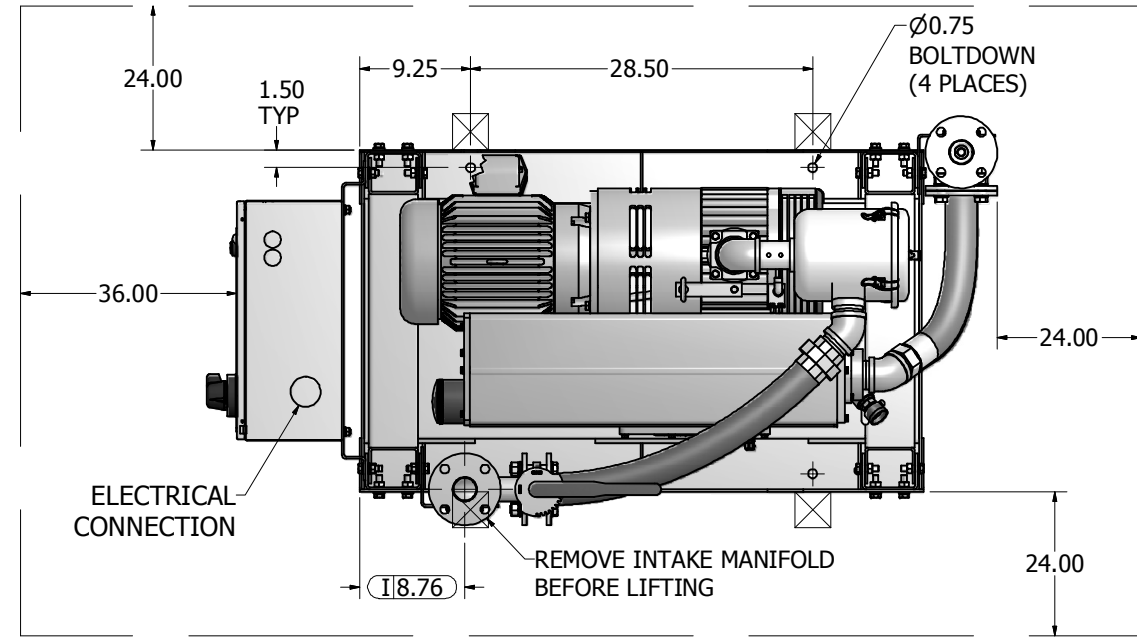

MINIMUM CLEARANCE FOR MAINTENANCE & VENTILATION

OUTLET 2" FLANGE

RECEIVER BYPASS VALVE

MANUAL DRAIN CONN 1/2" NPT (FEMALE)

HOSPITAL CONN 2" FLANGE

0.56 X 0.88 SLOT Ø26.00 B.C. EQUALLY SPACED (4 PLACES)

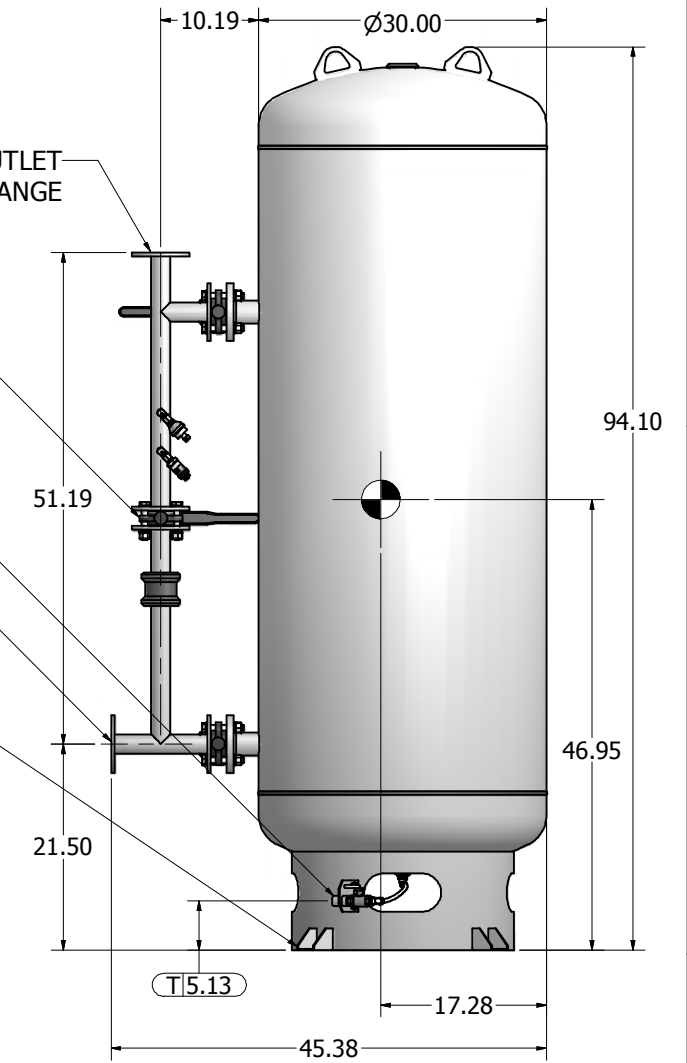

240 GAL VACUUM RECEIVER
2" FLANGED CONNECTIONS
(SCALE 1:10)

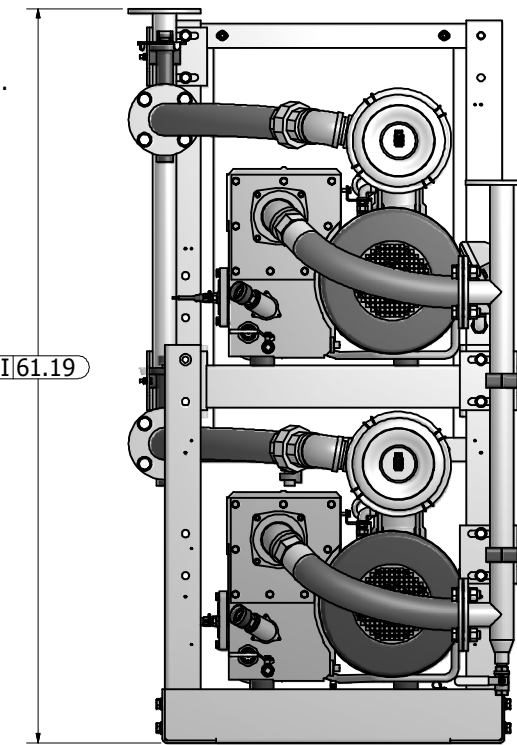
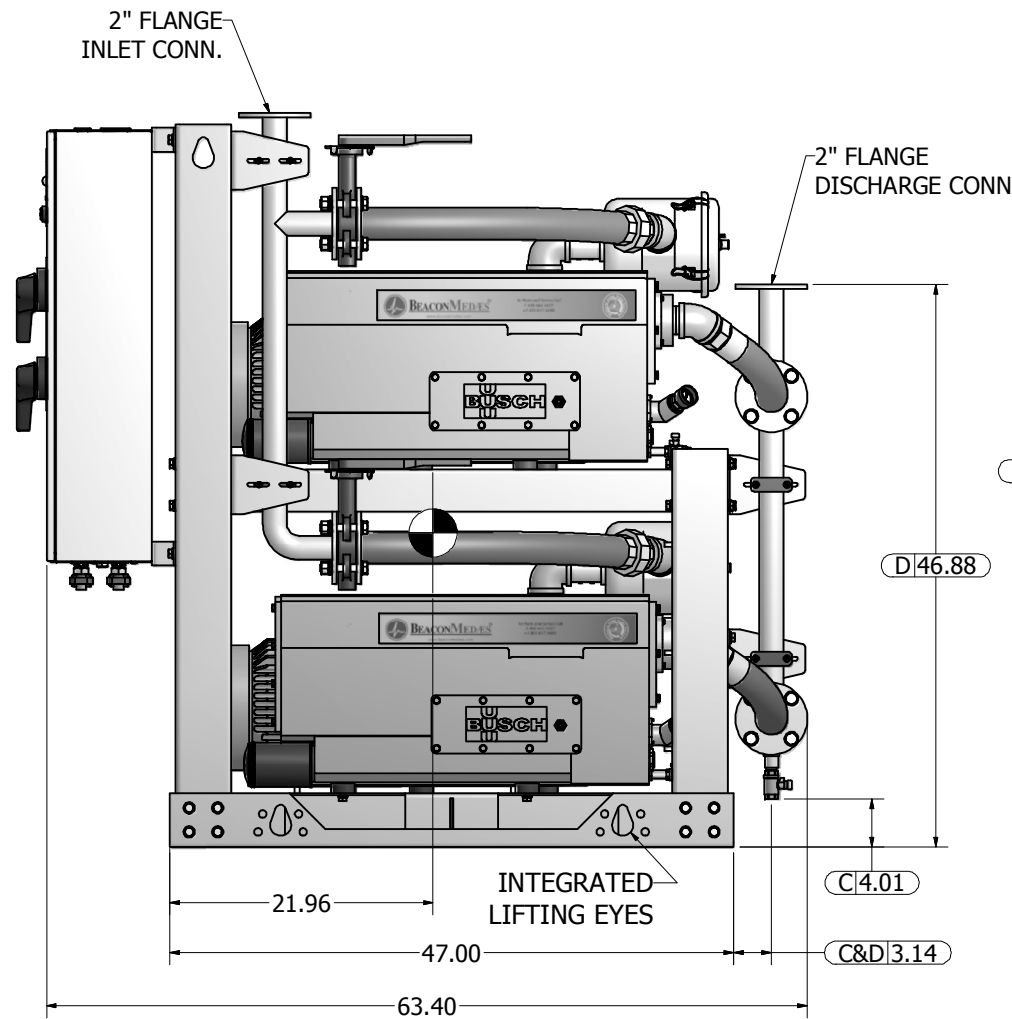
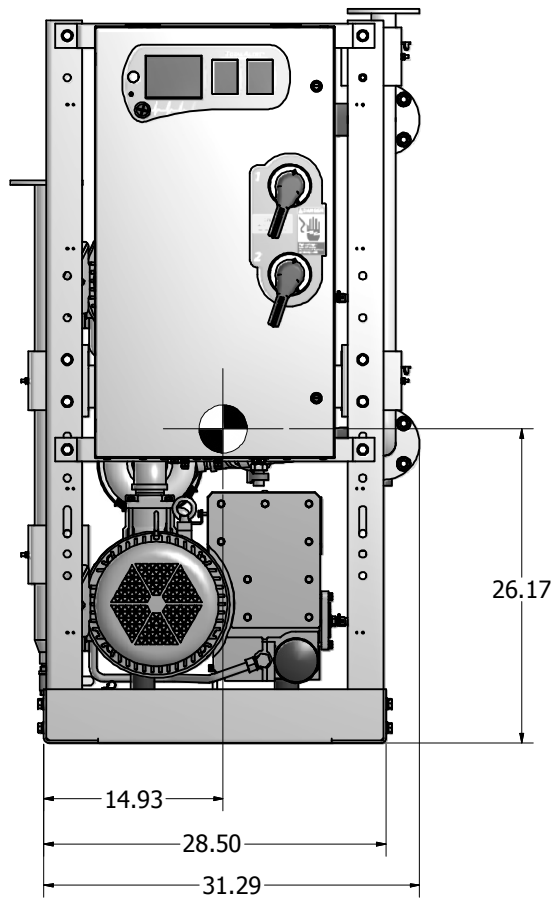

Revised:	Date:	Drawn: USNKW	Date: 10/20/2010
		This drawing and the information contained therein remain the property of BeaconMedes and may not be used for other than the purpose for which it is loaned without the expressed written permission from BeaconMedes Engineering.	
Description: GENERAL ASSEMBLY 7.5HP DX LUBE VAC MOD 240G RECEIVER		Part Number: 4107 8522 10 DN: HOP100727 Rev: 00 Sheet 1 of 1	
		Scale: 1/8 D DO NOT SCALE THIS DOCUMENT	