

Notes:

- DX MODULE WEIGHT: 1,419 LBS
200G TANK WEIGHT: 618 LBS
- ☒ INDICATES LIFTING POINT.
- DENOTES CENTER OF GRAVITY.

SYSTEM CONNECTIONS	
ID	DESCRIPTION
I	INLET LOCATION
D	DISCHARGE LOCATION
C	CONDENSATE DRAIN LOCATION
T	TANK DRAIN

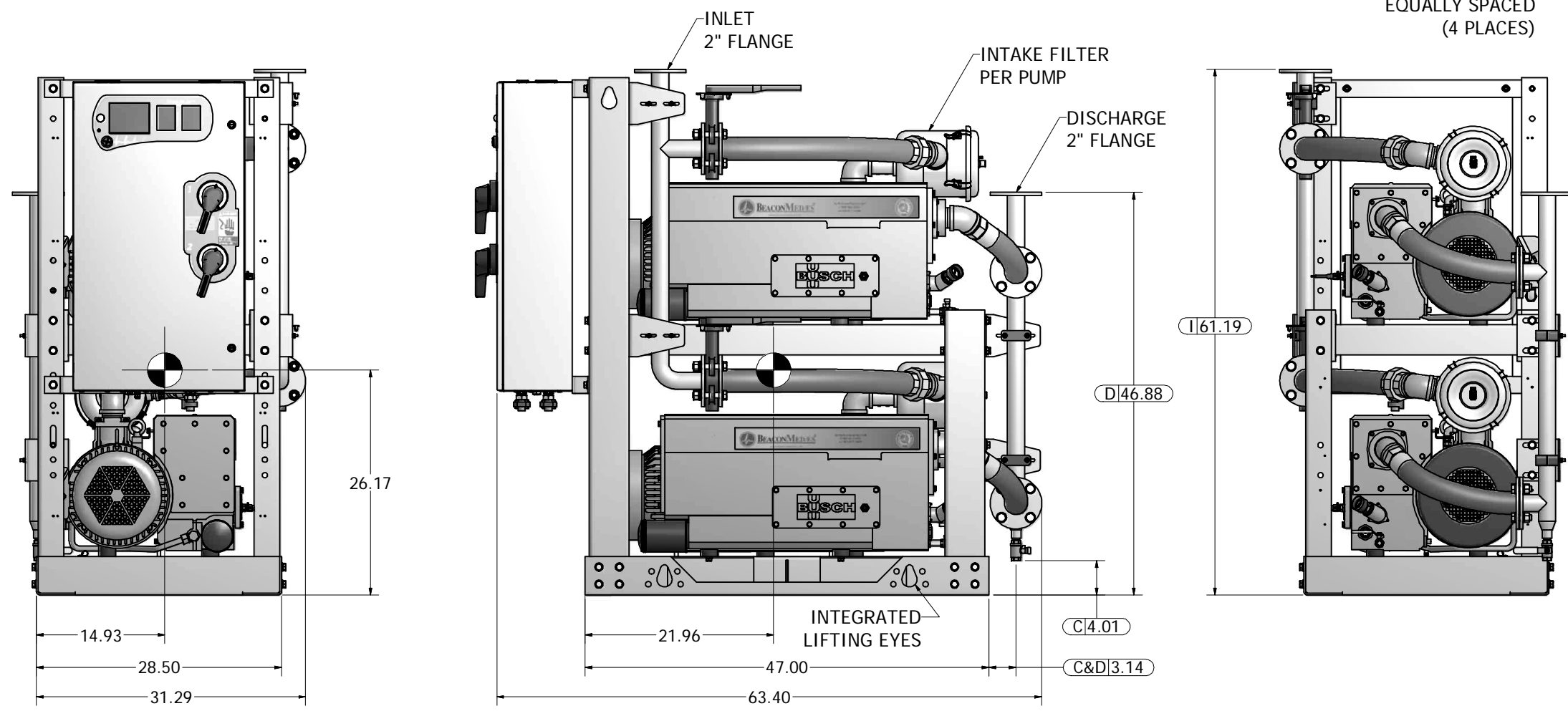
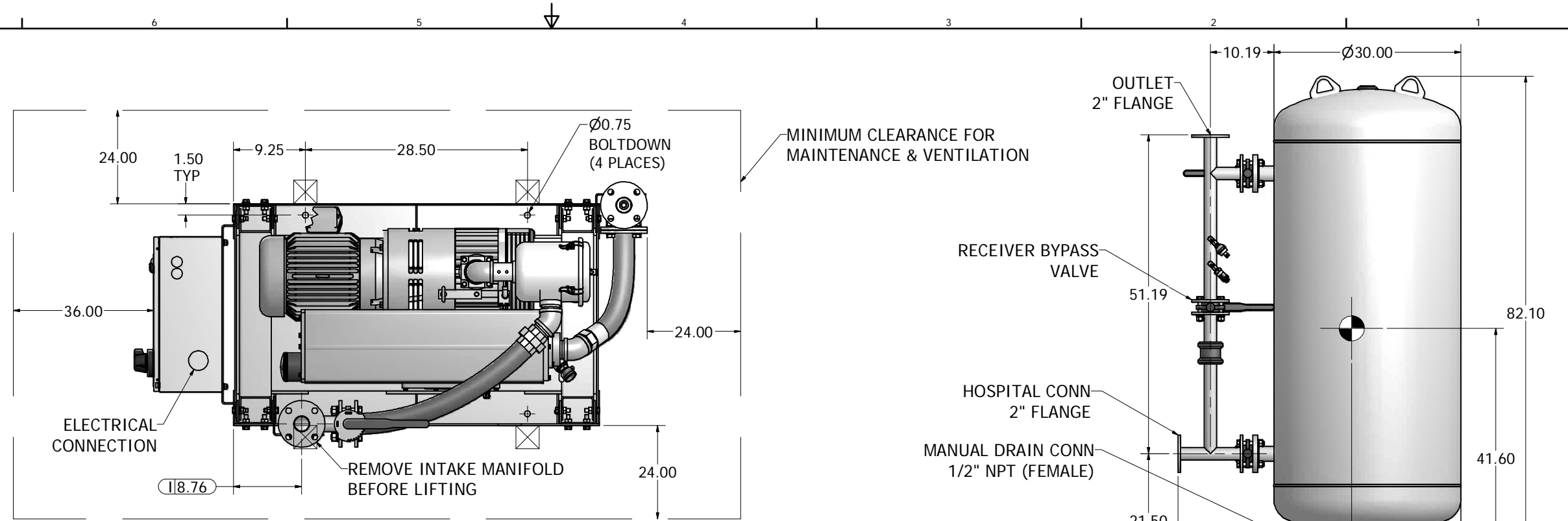

200 GAL VACUUM RECEIVER
2" FLANGED CONNECTIONS
(SCALE 1:10)

Revised:	Date:	Drawn:	Date:
		USNKW	10/20/2010
		This drawing and the information contained therein remain the property of BeaconMedes and may not be used for other than the purpose for which it is loaned without the expressed written permission from BeaconMedes Engineering.	
Description:		Part Number:	
GENERAL ASSEMBLY 7.5HP DX LUBE VAC MOD 200G RECEIVER		4107 8522 09	
DN:		Rev:	
HOP100727		00	
Sheet 1 of 1		DO NOT SCALE THIS DOCUMENT	