

Notes:

- DX MODULE WEIGHT: 1,419 LBS
120G TANK WEIGHT: 393 LBS
- ☒ INDICATES LIFTING POINT.
- DENOTES CENTER OF GRAVITY.

SYSTEM CONNECTIONS	
ID	DESCRIPTION
I	INLET LOCATION
D	DISCHARGE LOCATION
C	CONDENSATE DRAIN LOCATION
T	TANK DRAIN

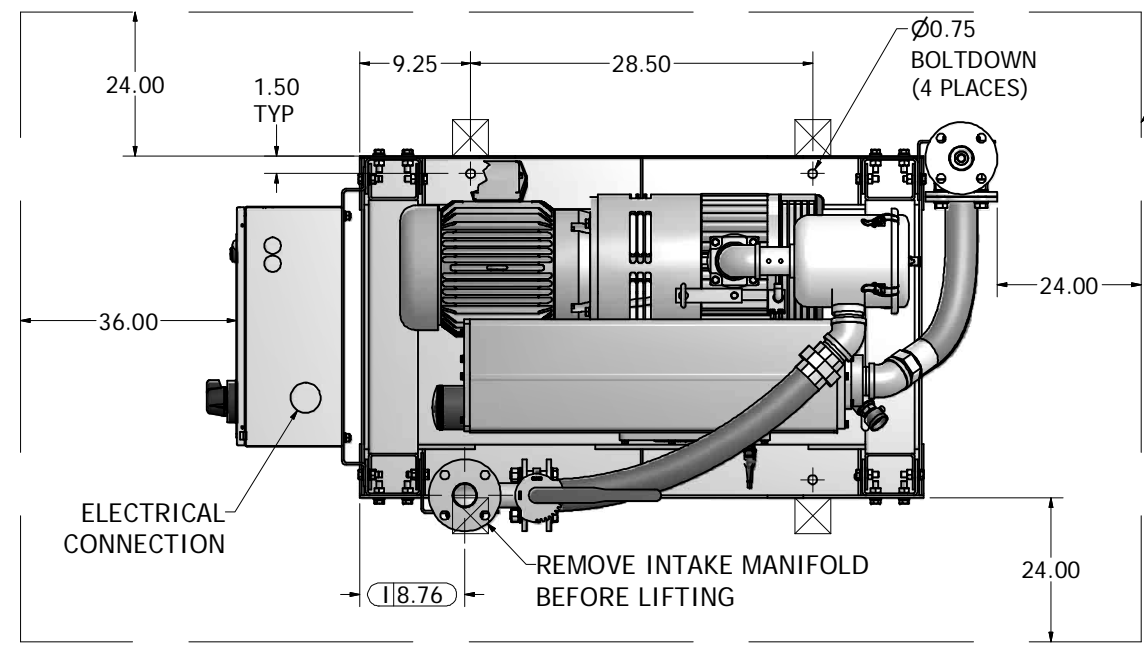

MINIMUM CLEARANCE FOR MAINTENANCE & VENTILATION

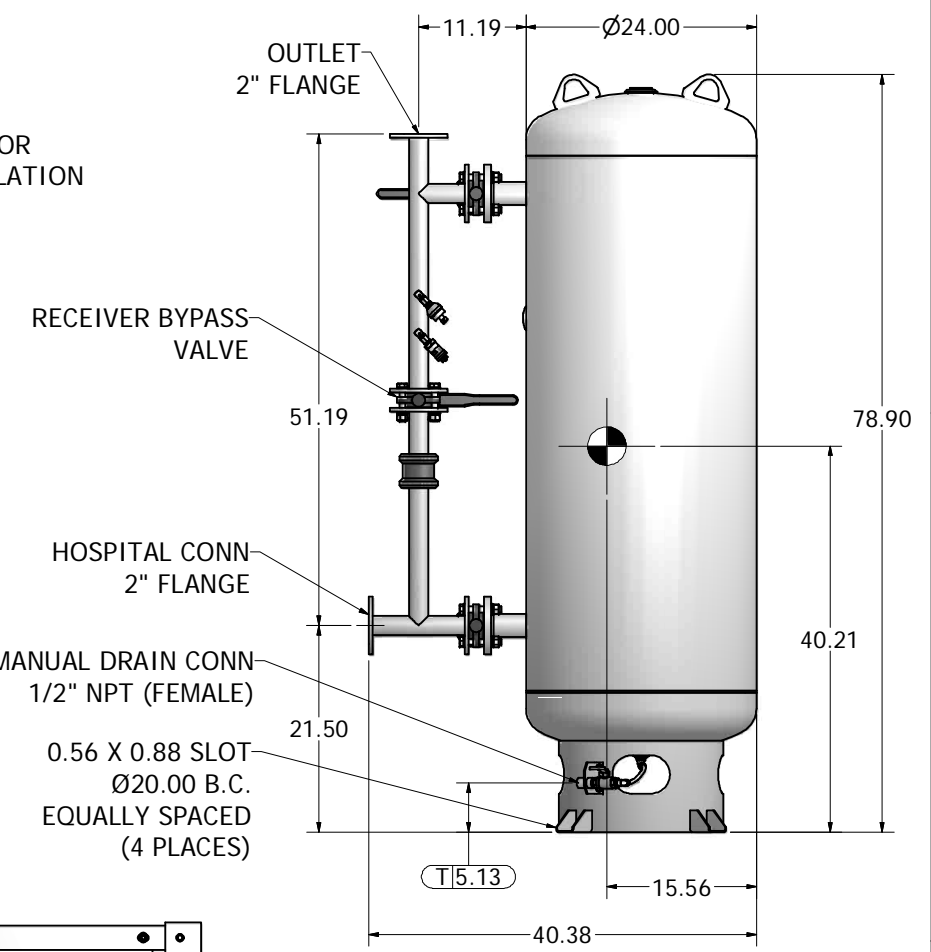

120 GAL VACUUM RECEIVER
2" FLANGED CONNECTIONS
(SCALE 1:10)

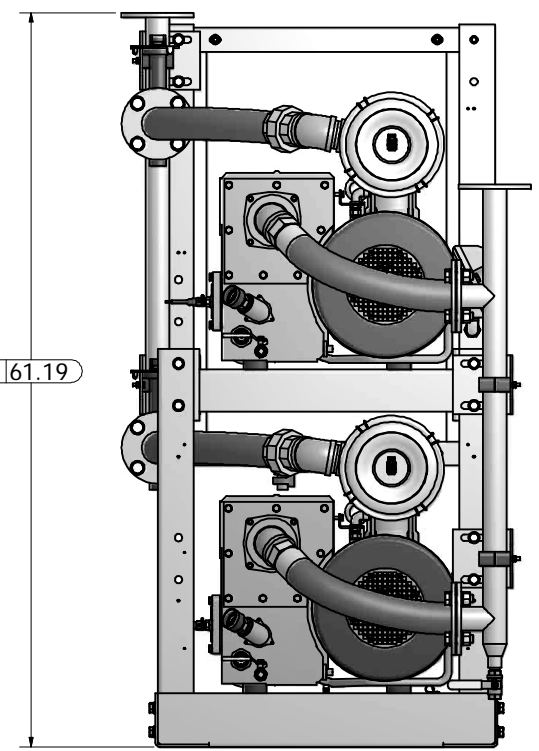
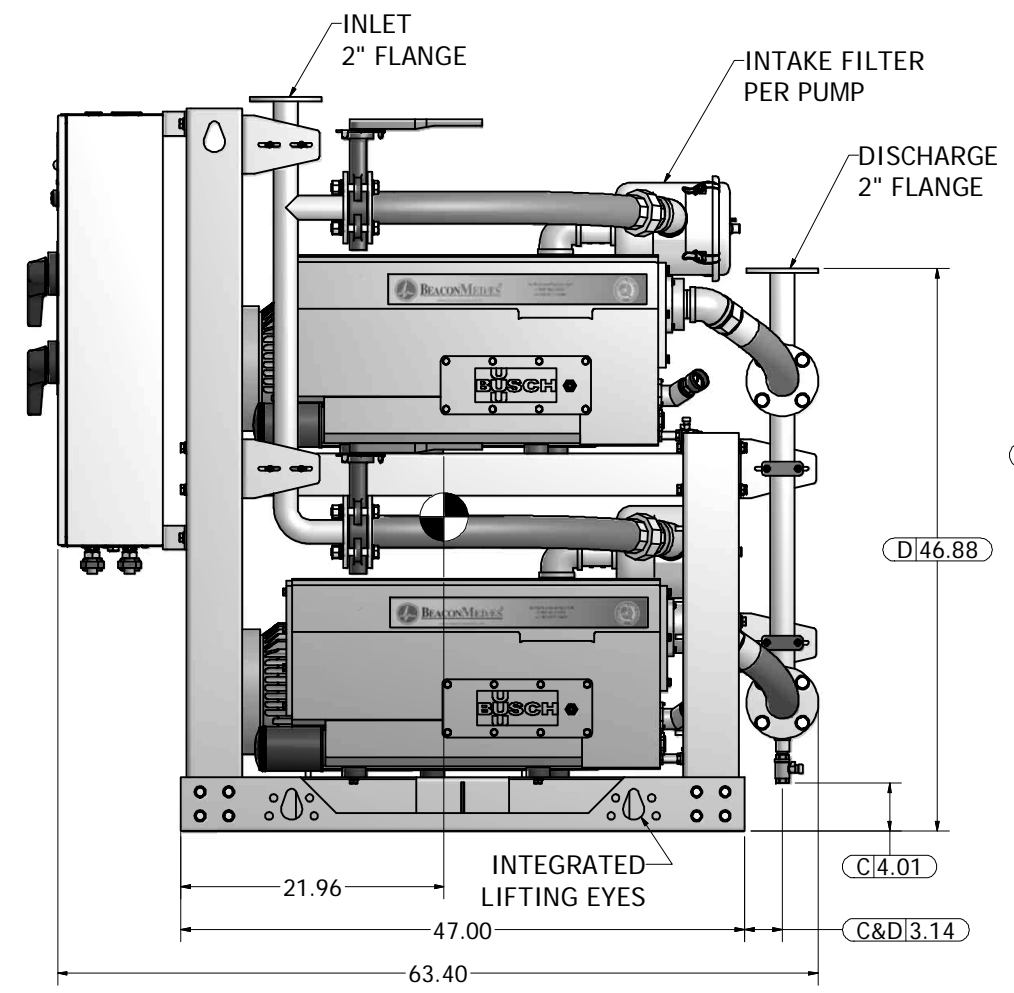
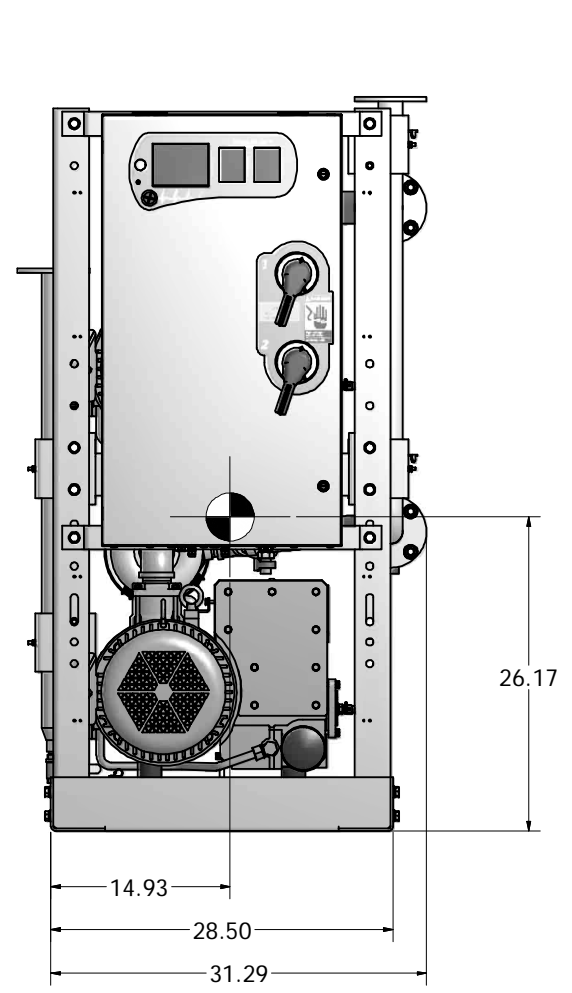

Revised:	Date:	Drawn: USNKW	Date: 10/20/2010
		This drawing and the information contained therein remain the property of BeaconMedies and may not be used for other than the purpose for which it is loaned without the expressed written permission from BeaconMedies Engineering.	
Description: GENERAL ASSEMBLY 7.5HP DX LUBE VAC MOD 120G RECEIVER		Part Number: 4107 8522 08 DN: HOP100727 Rev: 00 Sheet 1 of 1 DO NOT SCALE THIS DOCUMENT	