

COMPLETE SYSTEM MODEL NO.	RECEIVER (GAL)	UNIT (HP)	CAPACITY @ 19" Hg (SCFM)		NOISE LEVEL dB(A)	SYSTEM WEIGHT (lbs)
			PUMP	SYSTEM		
LPV-7T-RC120V-T_	120	7.5	41	82	77	~1,722

- NOTES:
1. INTAKE, DISCHARGE, SEAL WATER FLEX HOSES AND VIBRATION ISOLATORS WILL BE SHIPPED LOOSE.
 2. ALLOW 36 INCHES IN FRONT OF CONTROL PANEL FOR MAINTENANCE AND VENTILATION, ALL OTHER SIDES REQUIRE 24 INCHES OF CLEARANCE.
 3. NOISE LEVEL AND SYSTEM DATA REFLECT TWO VACUUM PUMP IN OPERATION.
 4. _ INDICATES VOLTAGE REQUIREMENTS: A = 208V, B = 230V & C = 460V
 5. VACUUM RECEIVER REMOVED IN TOP VIEW.

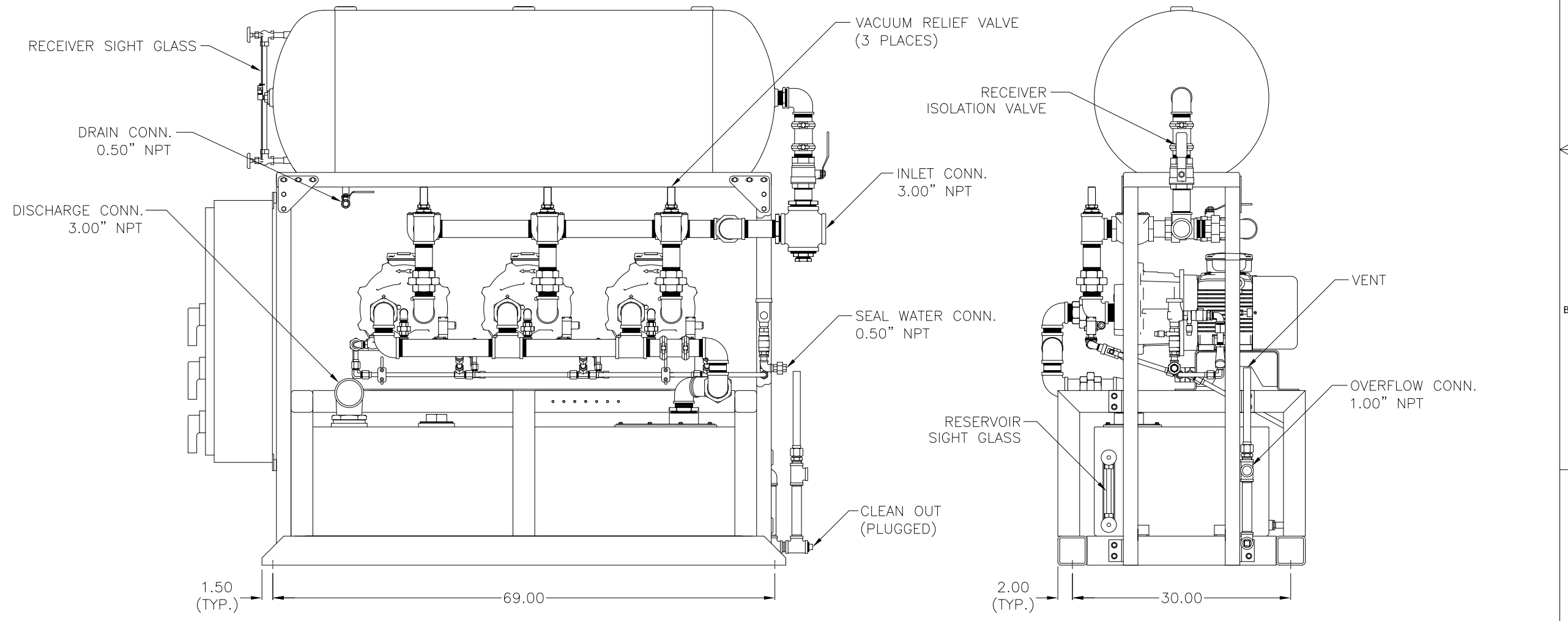
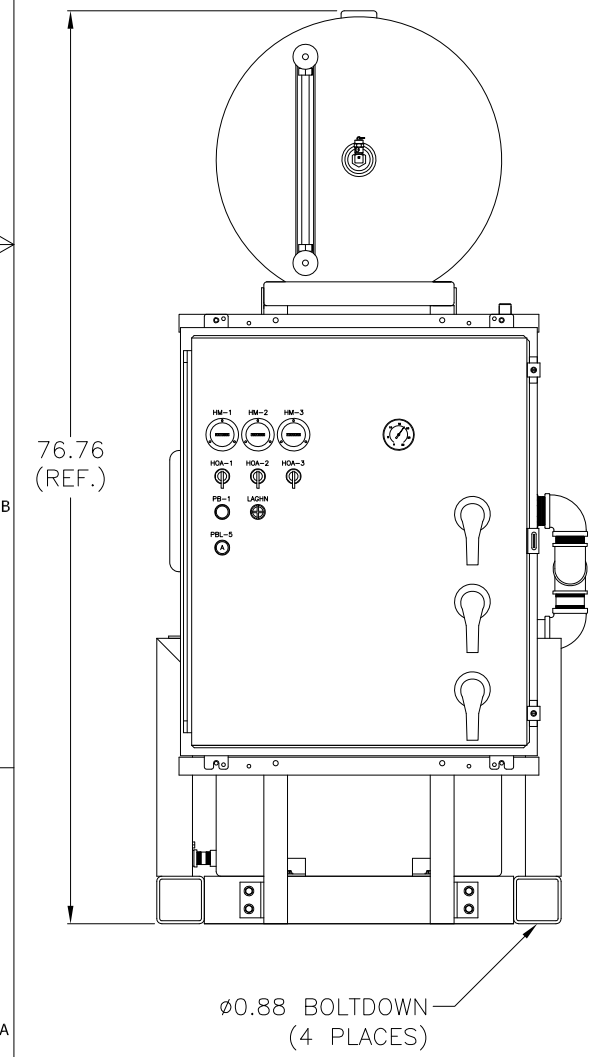

Revised: BKW	Date: 9/21/2016	Drawn: CCC	Date: 7/22/10
BEACONMEDIAS <small>This drawing and the information contained therein remain the property of BeaconMedias and may not be used for other than the purpose for which it is loaned without the expressed written permission from BeaconMedias Engineering.</small>			Scale: 1/8 D
Description: GEN ASM LL TPX CAMEL VACUUM SYSTEM TYPE 1 - VECTRA SX25/7.5HP, 120 G		Part Number: 4107 8521 76	
DN: HOP161044		Rev: 02	
Sheet 1 of 1		DO NOT SCALE THIS DOCUMENT	