

- Notes:
- DISCHARGE MUFFLER WILL BE SHIPPED LOOSE.
 - SYSTEM WEIGHT: 1,663 LBS.
 - ☒ INDICATED LIFTING POINT.
 - DENOTES CENTER OF GRAVITY.

SYSTEM CONNECTIONS	
ID	DESCRIPTION
I	INLET LOCATION
D	DISCHARGE LOCATION
C	CONDENSATE DRAIN LOCATION
T	TANK DRAIN LOCATION

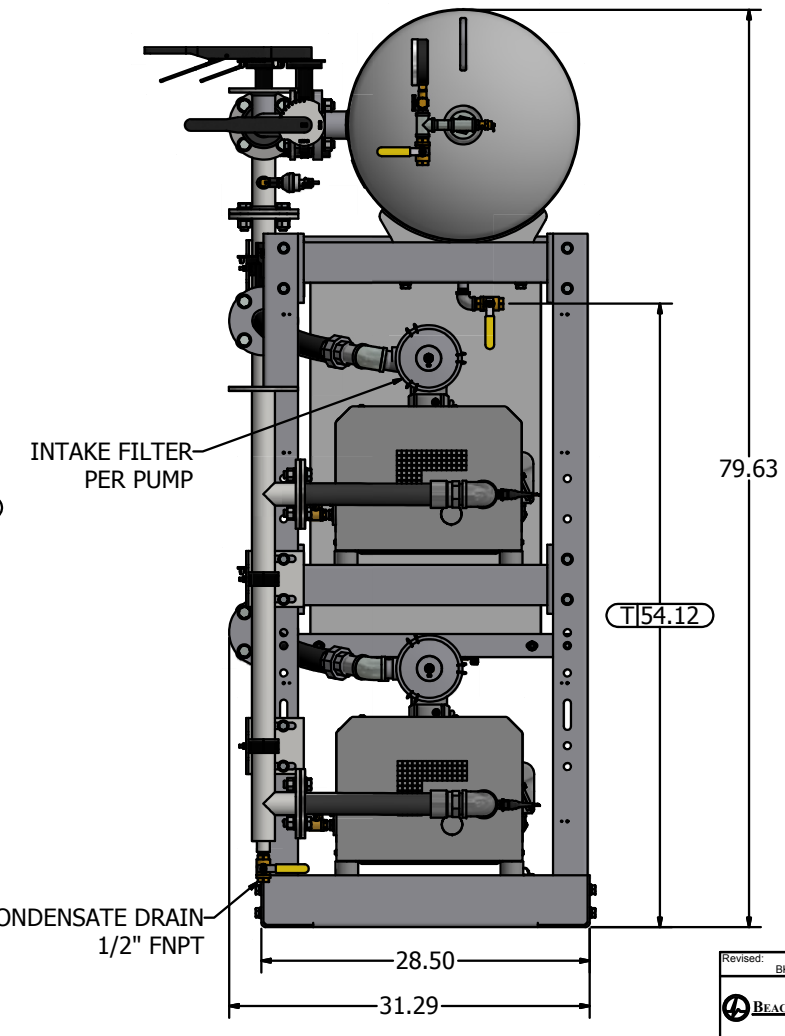
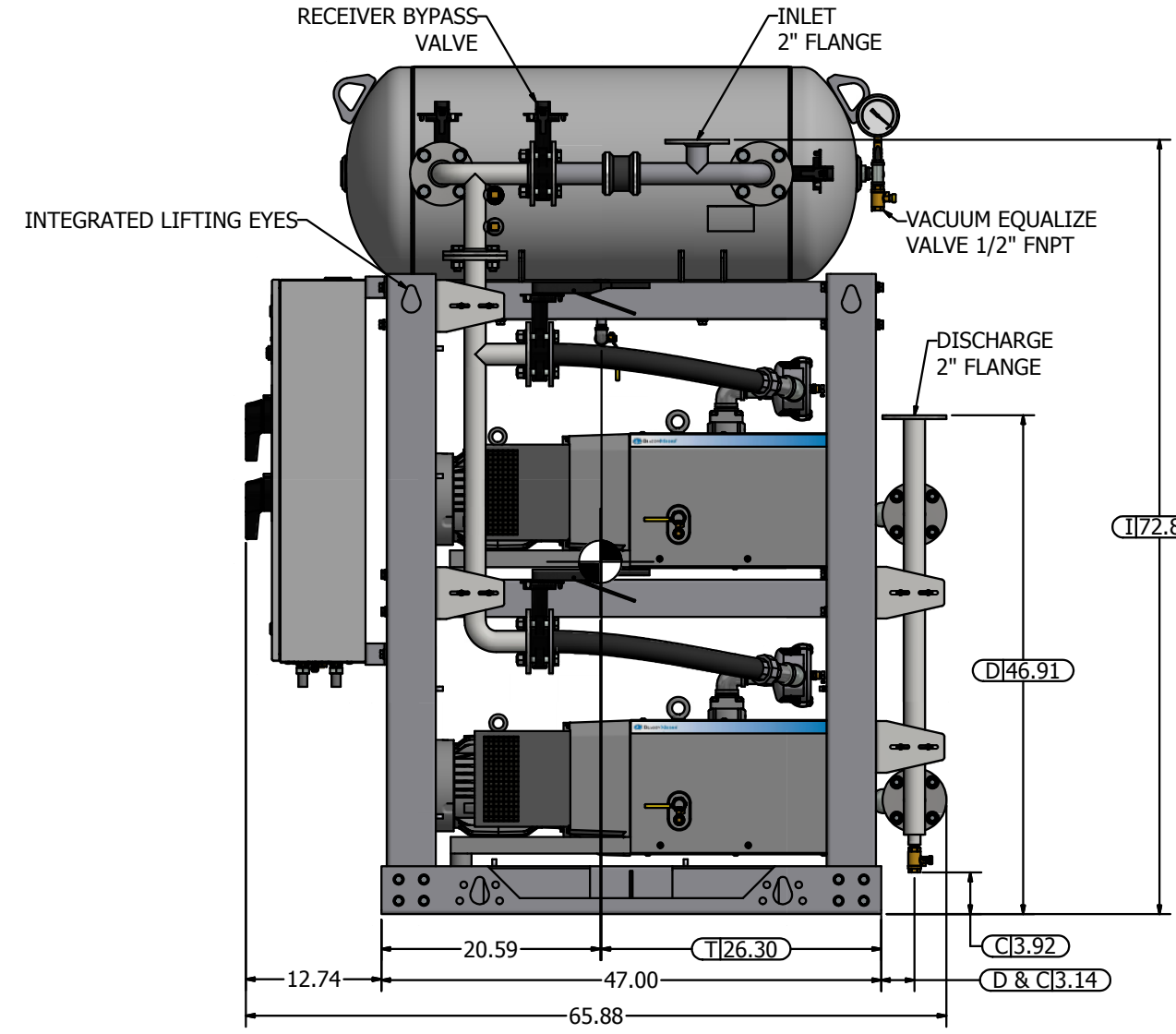
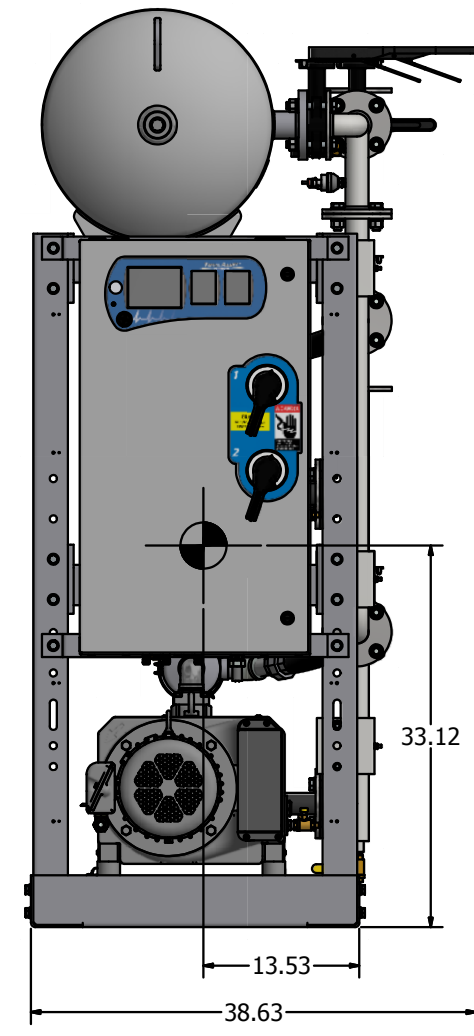
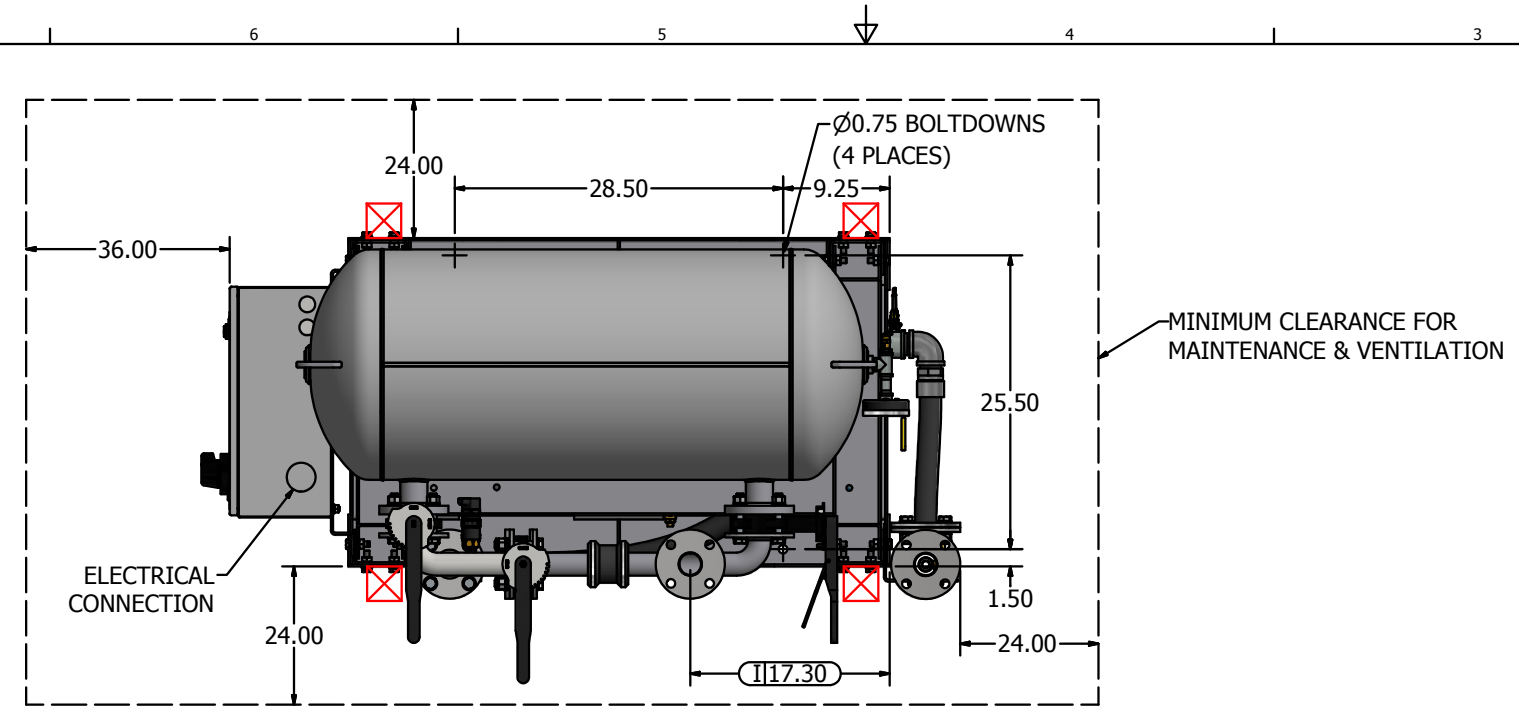

Revised: BKW	Date: 9/29/2017	Drawn: JDY	Date: 1/19/2010
		This drawing and the information contained therein remain the property of BeaconMedes and may not be used for other than the purpose for which it is loaned without the expressed written permission from BeaconMedes Engineering.	
Description: GENERAL ASSEMBLY 3HP DX CLAW VAC STM 60G RECEIVER STANDARD & O2 ASSURED		Part Number: 4107 8518 00 DN: HOP170887 Rev: 02 Sheet 1 of 1 DO NOT SCALE THIS DOCUMENT	