





- Notes:
1. DISCHARGE MUFFLER WILL BE SHIPPED LOOSE.
 2. SYSTEM WEIGHT: 1,629 LBS.
 3.  INDICATES LIFTING POINT.
 4.  DENOTES CENTER OF GRAVITY.

| SYSTEM CONNECTIONS | |
|--------------------|---------------------------|
| ID | DESCRIPTION |
| I | INLET LOCATION |
| D | DISCHARGE LOCATION |
| C | CONDENSATE DRAIN LOCATION |
| T | TANK DRAIN LOCATION |

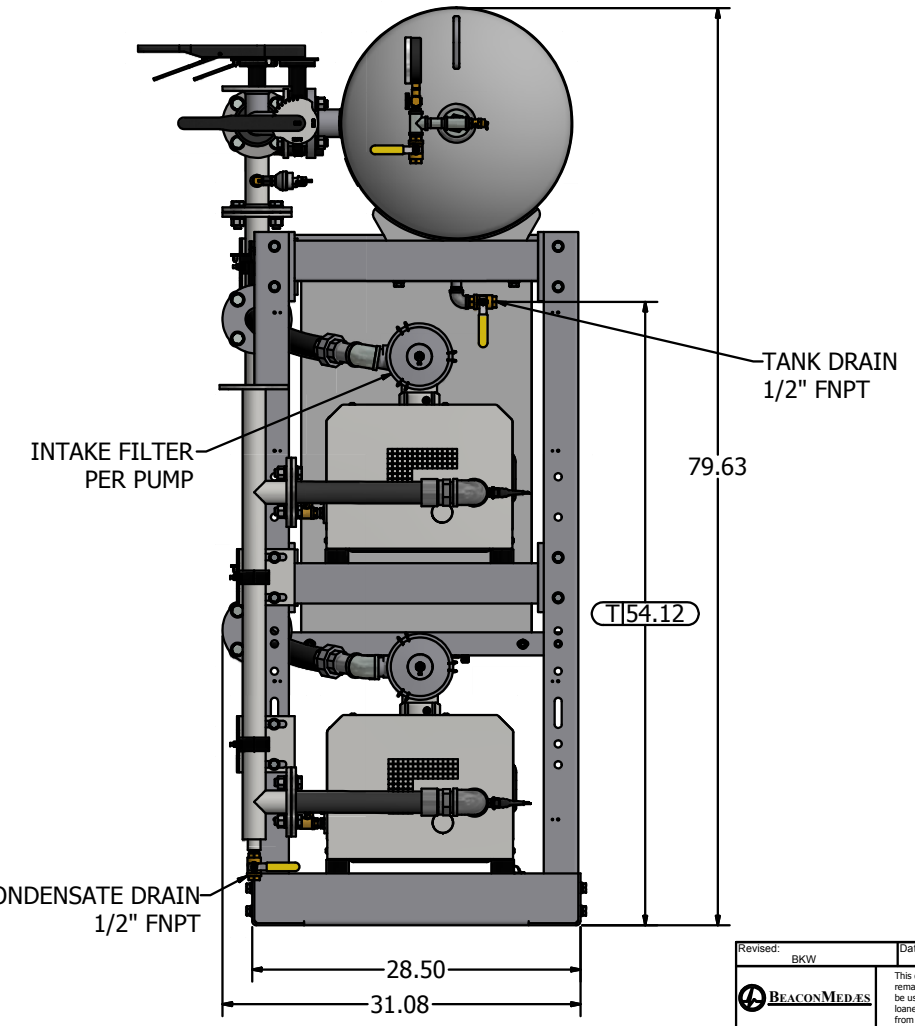
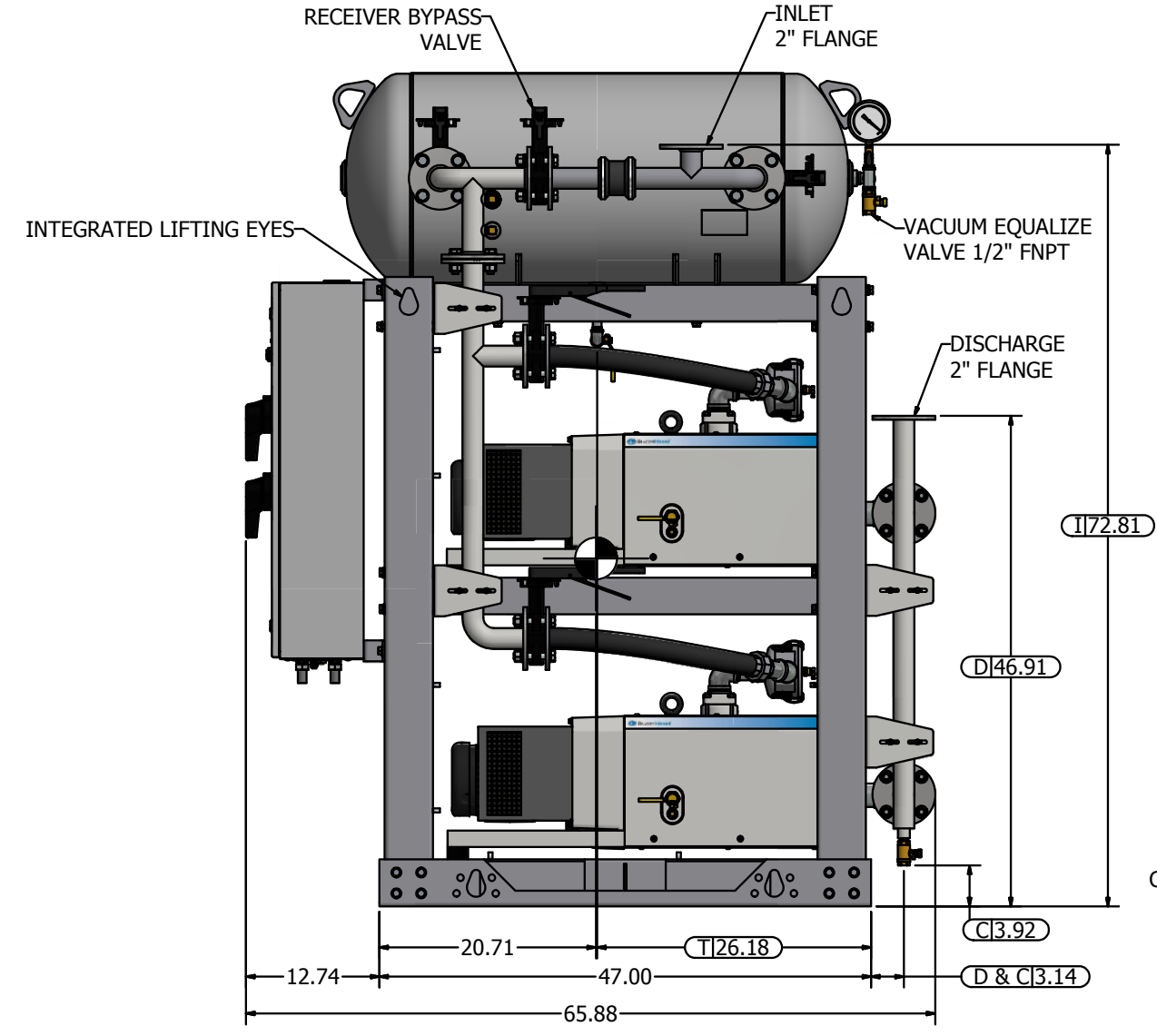
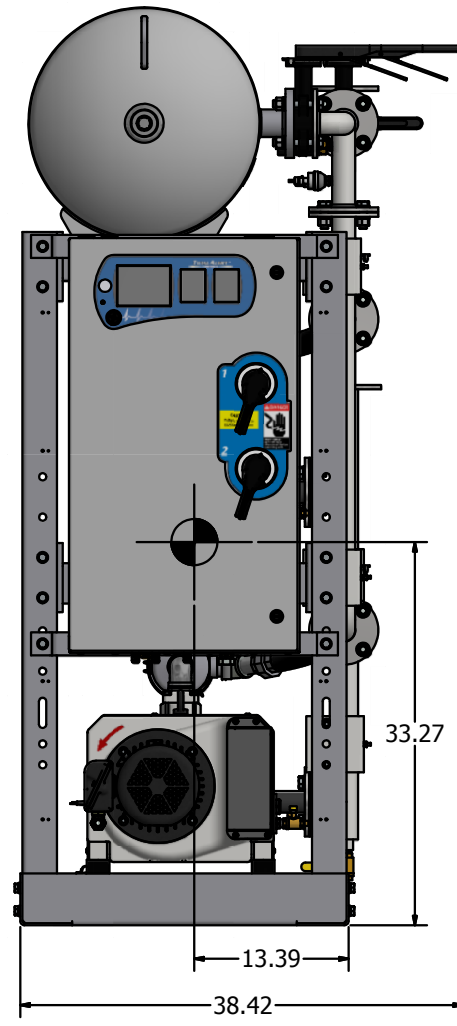
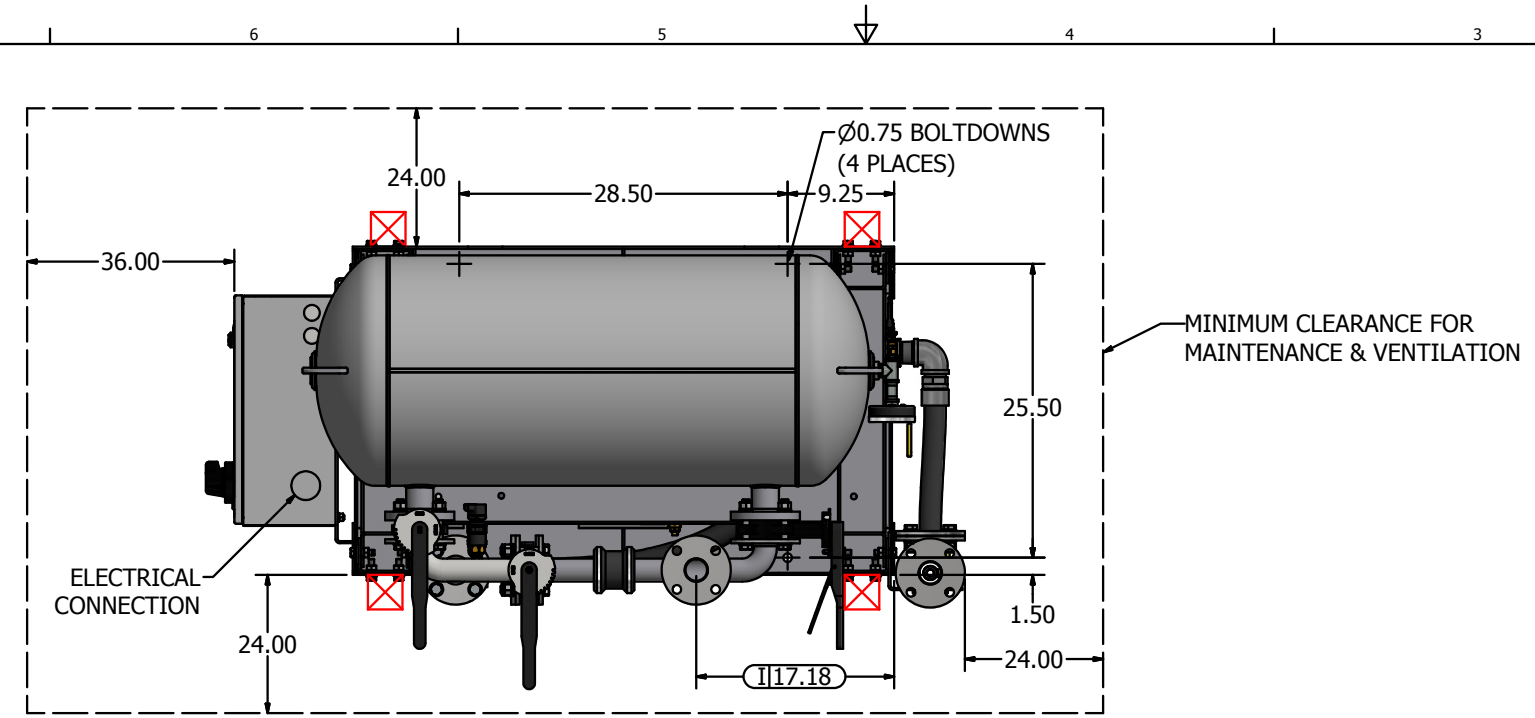

| | | | |
|--|-----------------|----------------------------|-----------------|
| Revised: BKW | Date: 9/29/2017 | Drawn: JDY | Date: 1/19/2010 |
|  BEACONMEDES <small>This drawing and the information contained therein remain the property of BeaconMedes and may not be used for other than the purpose for which it is loaned without the expressed written permission from BeaconMedes Engineering.</small> | | Scale: D | |
| Description: GENERAL ASSEMBLY 2HP DX CLAW VAC STM 60G RECEIVER STANDARD & O2 ASSURED | | Part Number: 4107 8517 99 | |
| DN: HOP170887 | | Rev: 02 | |
| Sheet 1 of 1 | | DO NOT SCALE THIS DOCUMENT | |