

Notes:

- DISCHARGE MUFFLER WILL BE SHIPPED LOOSE.
- WEIGHT OF DUPLEX MODULE W/ PANEL: 2,333 LBS
WEIGHT OF FUTURE SIMPLEX MODULE : 1,219 LBS

240G TANK WEIGHT: 733 LBS

- ☒ INDICATES LIFTING POINT.

- DENOTES CENTER OF GRAVITY.

SYSTEM CONNECTIONS	
ID	DESCRIPTION
I	INLET LOCATION
D	DISCHARGE LOCATION
C	CONDENSATE DRAIN LOCATION
T	TANK DRAIN LOCATION

REMOVE JUNCTION BOX BEFORE LIFTING (LOCATED ON SX MODULE ONLY)

MINIMUM CLEARANCE FOR MAINTENANCE & VENTILATION

REMOVE INTAKE MANIFOLD BEFORE LIFTING (2 PLACES)

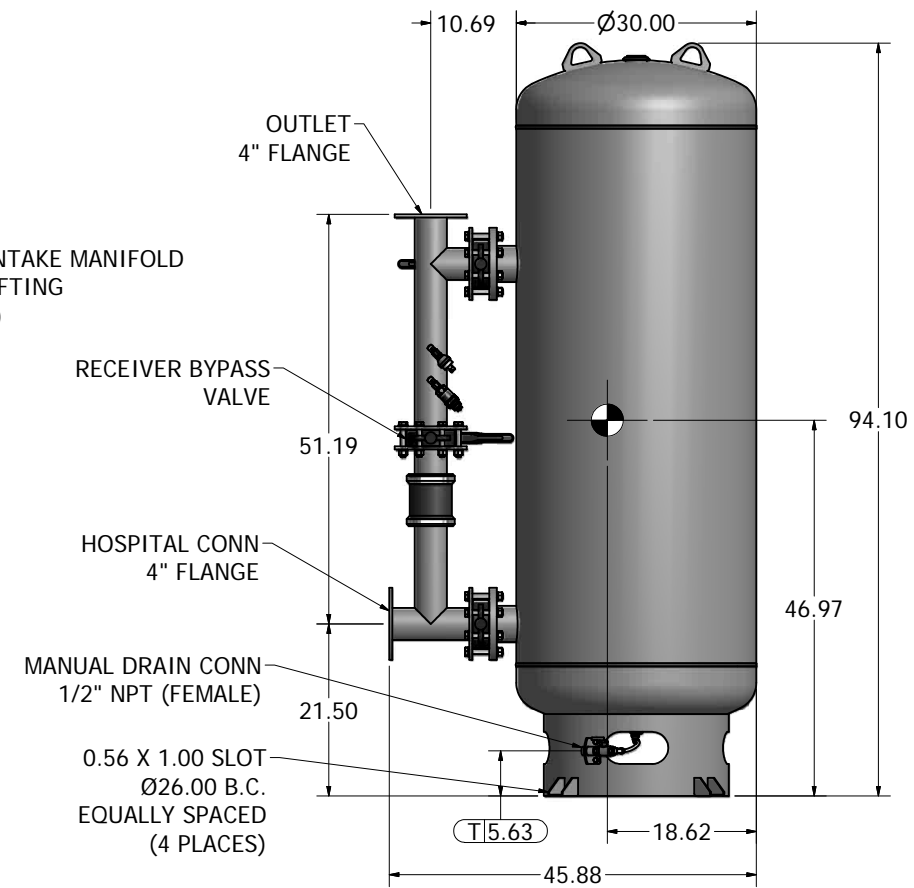
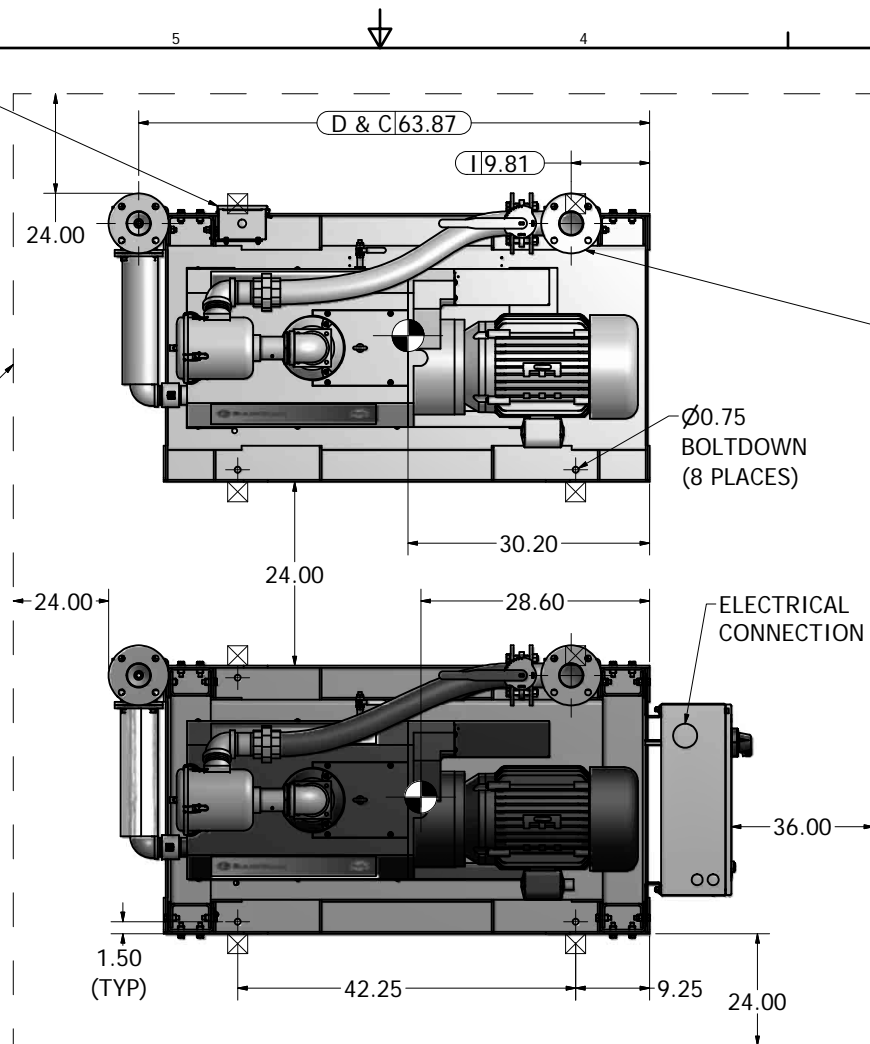

240 GAL VACUUM RECEIVER
4" FLANGED CONNECTIONS
(SCALE 1:12)

FUTURE EXPANSION MODULE

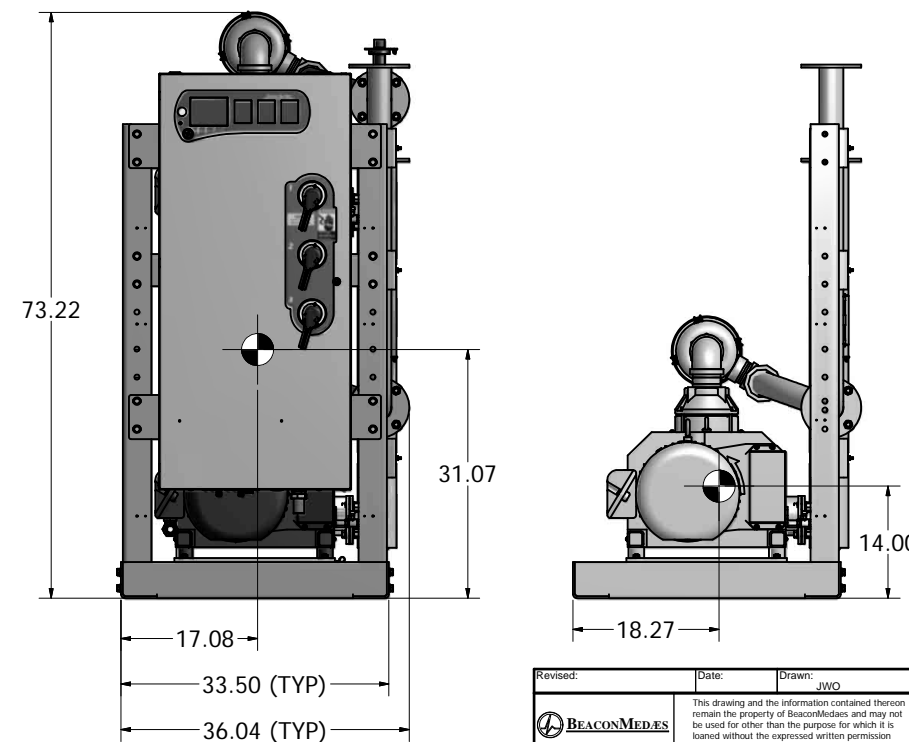
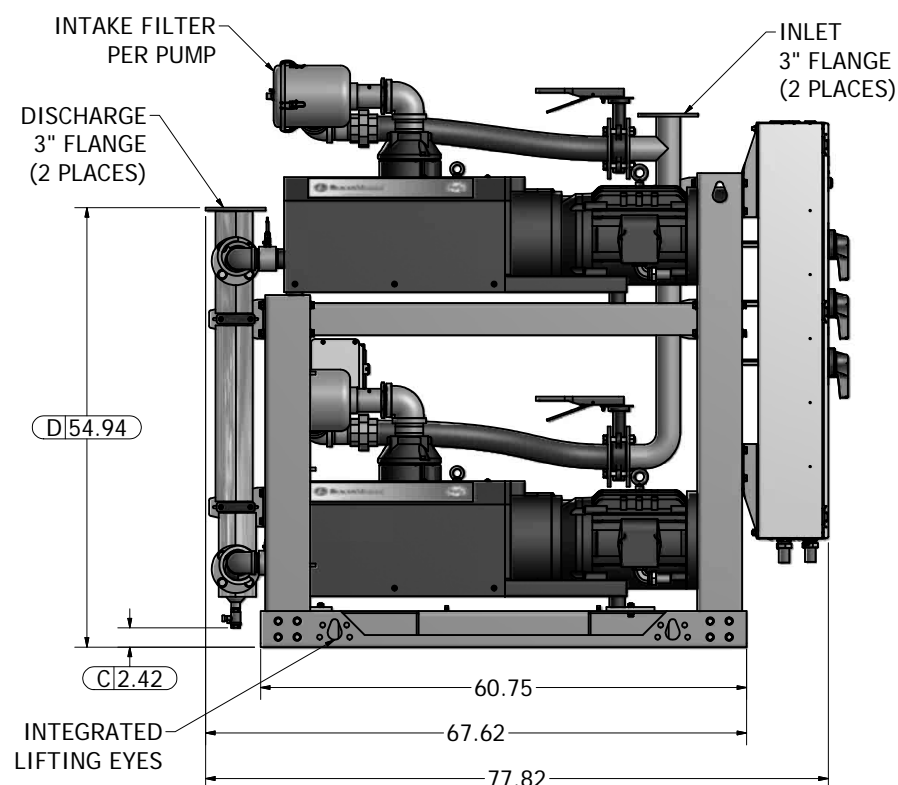
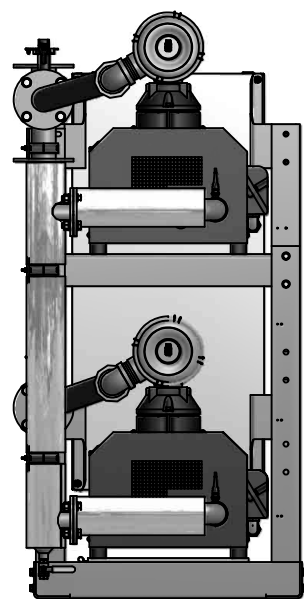
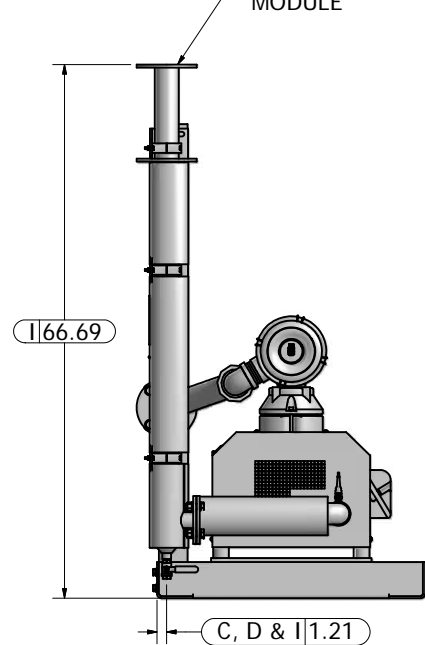

Revised:	Date:	Drawn:	Date:
		JWO	01/28/2014
		This drawing and the information contained therein remain the property of BeaconMedes and may not be used for other than the purpose for which it is loaned without the expressed written permission from BeaconMedes Engineering.	
Description: GENERAL ASSEMBLY 15HP DX-EXP-TX CLAW VAC MOD 240G RECEIVER STANDARD		Part Number: 4107 8549 43 DN: HOP131370 Rev: 00 Sheet 1 of 1 DO NOT SCALE THIS DOCUMENT	
		D	