

- NOTES:
- DISCHARGE MUFFLERS WILL BE SHIPPED LOOSE.
 - DX MODULE WEIGHT: 2,291 LBS.
240G TANK WEIGHT: 733 LBS
CONTROL PANEL WEIGHT: 229 LBS.
 - ☒ INDICATES LIFTING POINT.
 - DENOTES CENTER OF GRAVITY.

SYSTEM CONNECTIONS	
ID	DESCRIPTION
I	INLET LOCATION
D	DISCHARGE LOCATION
C	CONDENSATE DRAIN LOCATION
T	TANK DRAIN LOCATION

REMOVE INTAKE MANIFOLD BEFORE LIFTING (3 PLACES)

REMOVE JUNCTION BOX BEFORE LIFTING (3 PLACES)

MINIMUM CLEARANCE FOR MAINTENANCE & VENTILATION

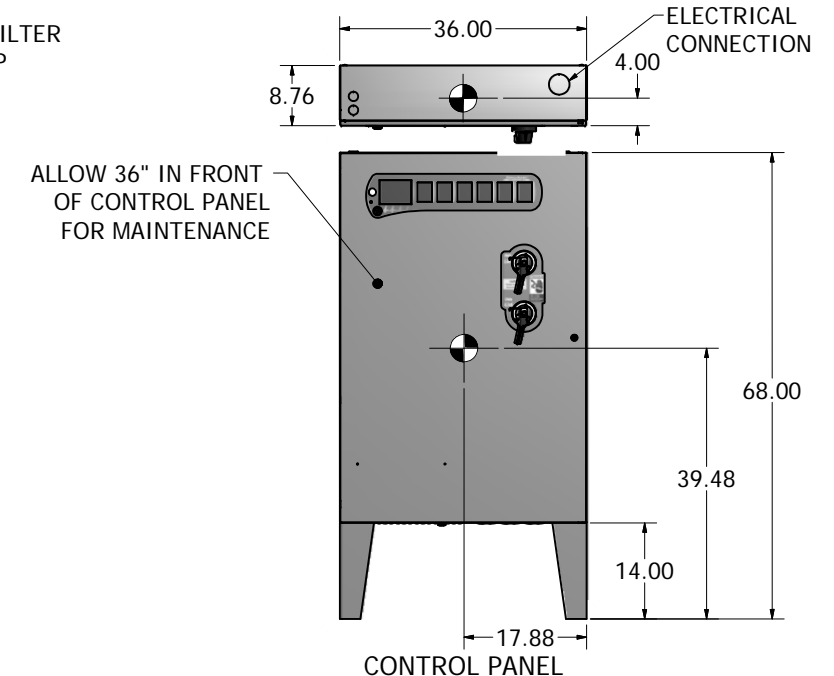
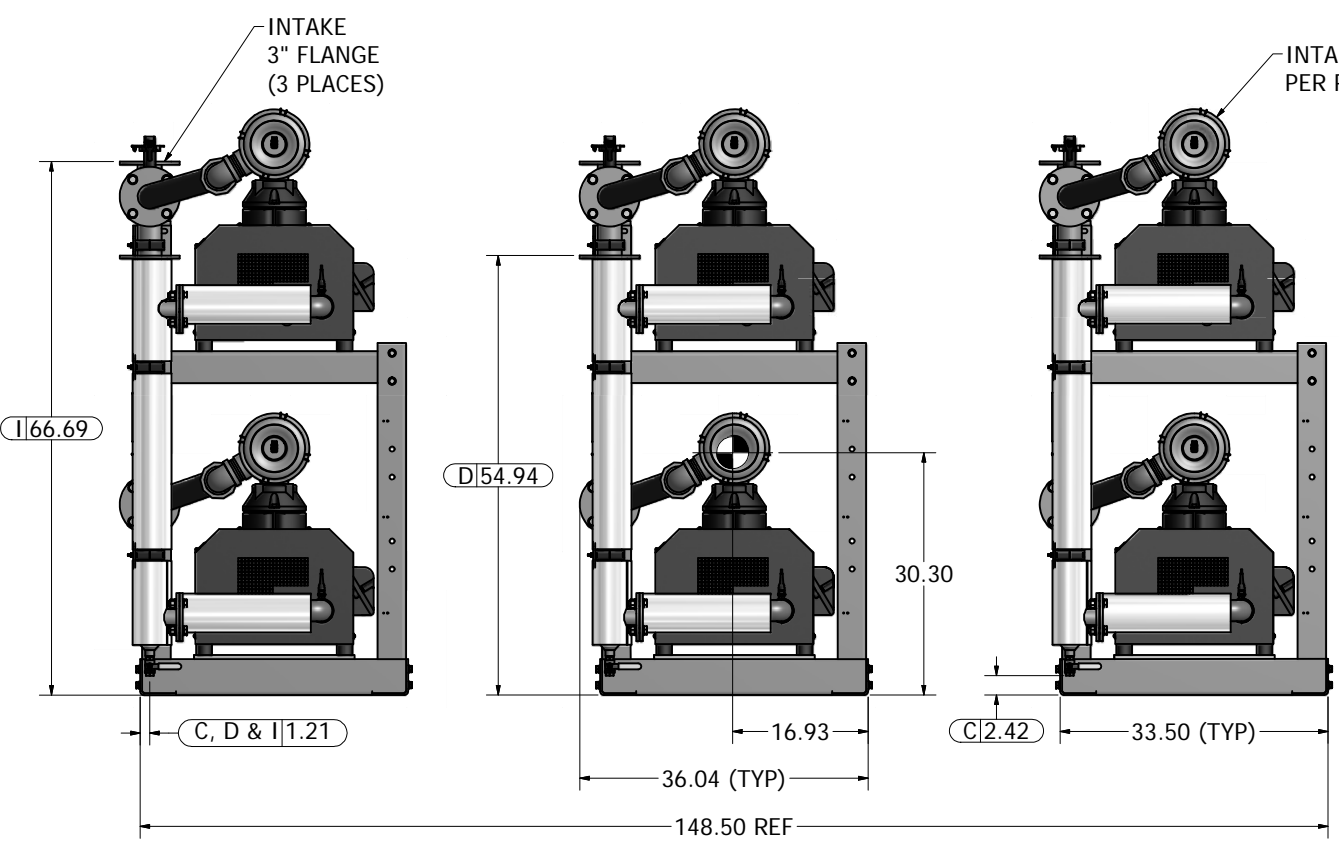
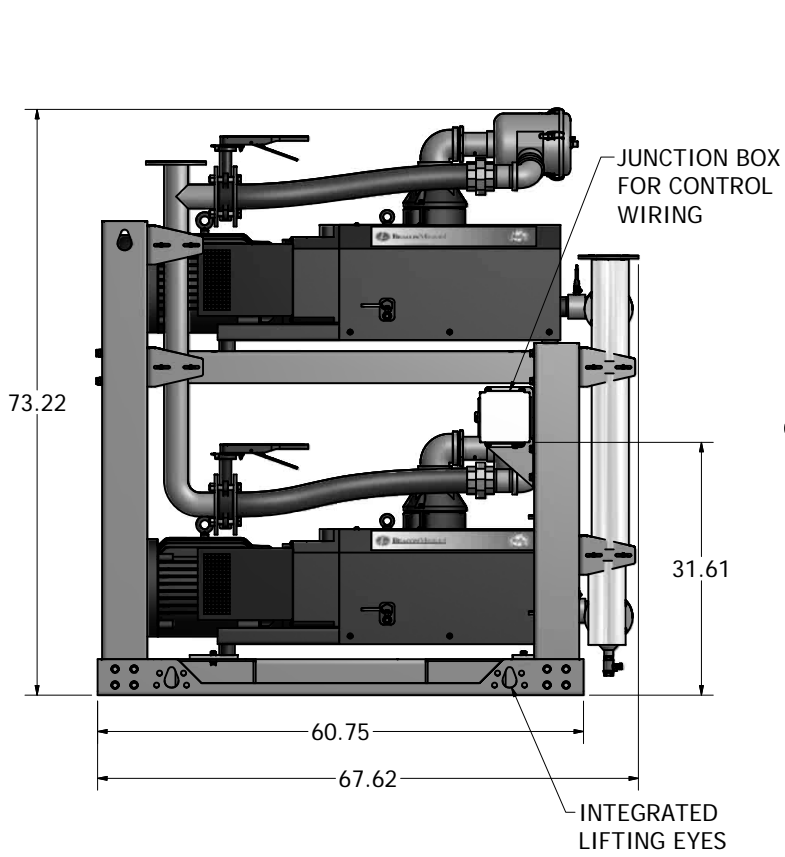
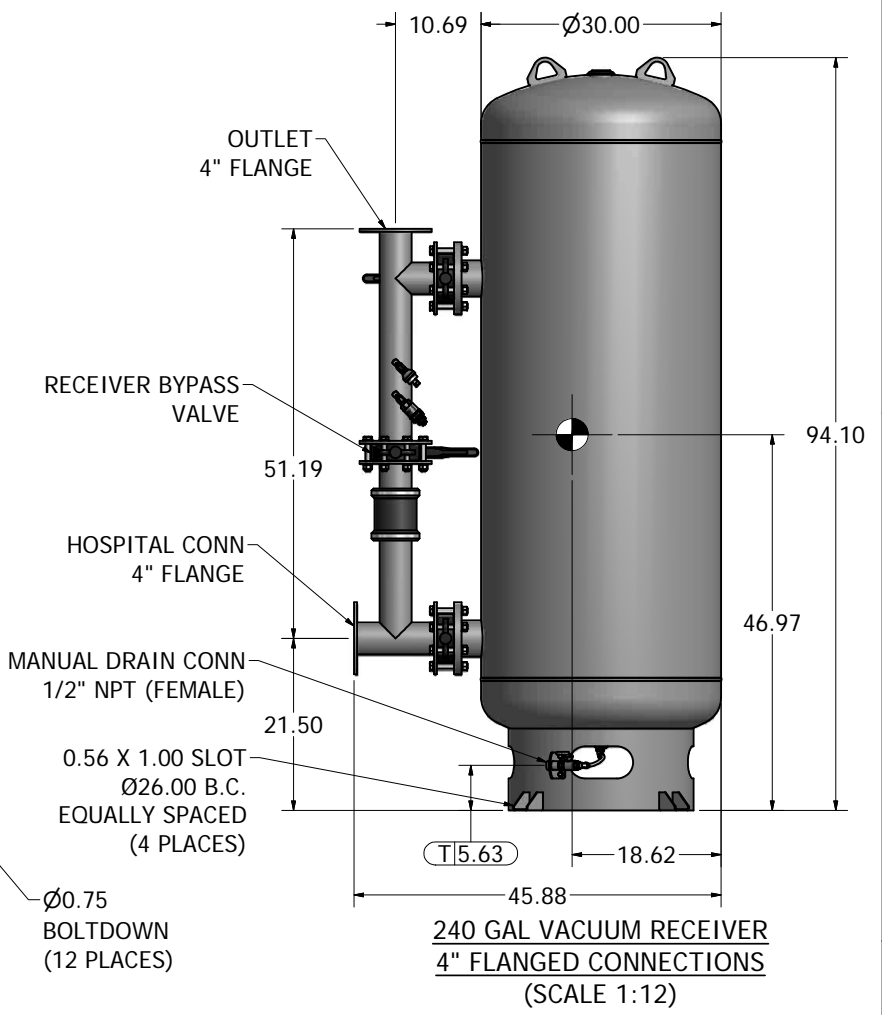
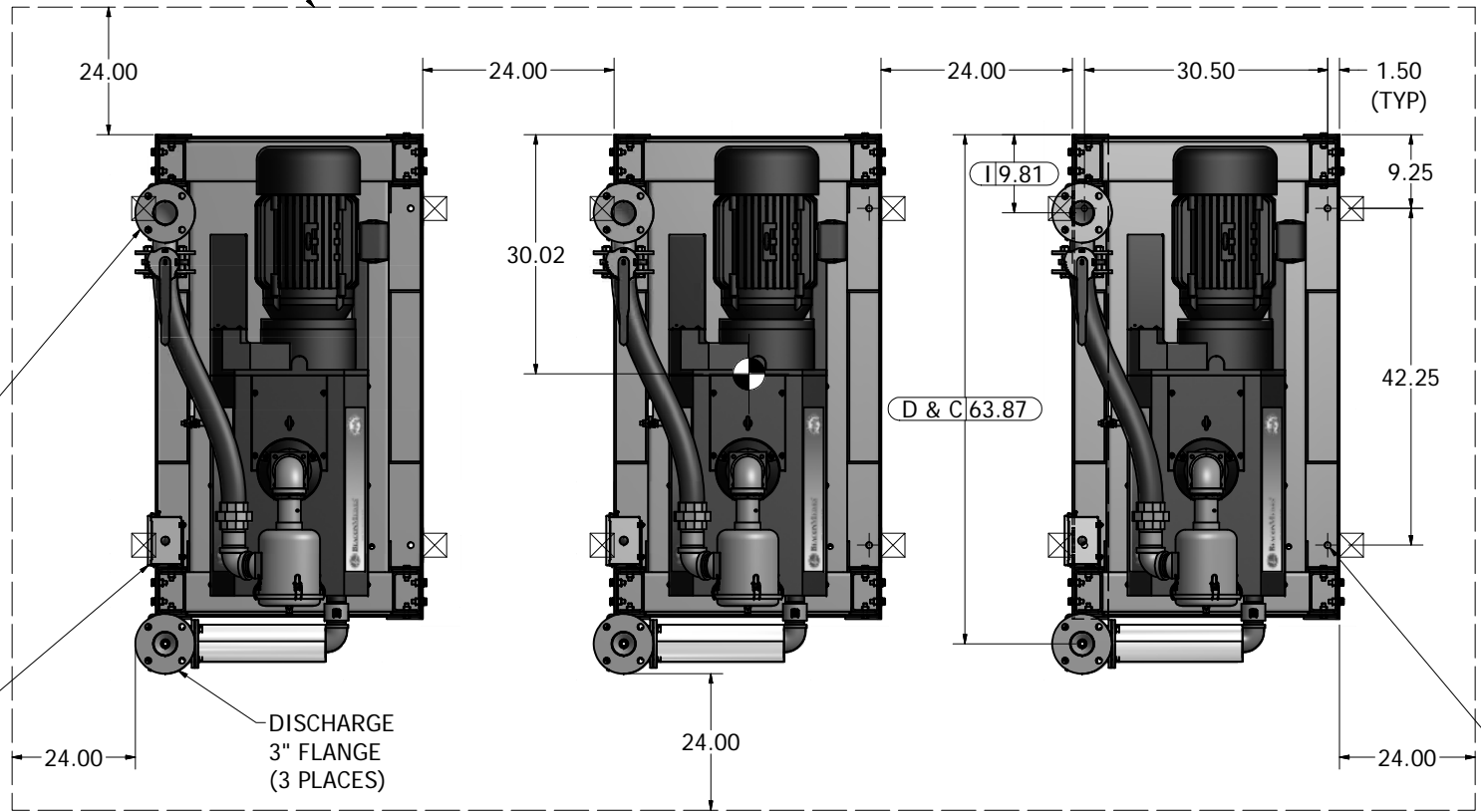

Revised:	Date:	Drawn:	Date:
		JWJ	02/07/2014
		This drawing and the information contained therein remain the property of BeaconMedes and may not be used for other than the purpose for which it is loaned without the expressed written permission from BeaconMedes Engineering.	
Description: GENERAL ASSEMBLY 15HP HX CLAW VAC MOD 240G RECEIVER STANDARD		Part Number: 4107 8549 11	
DN: HOP131370		Rev: 00	
Sheet 1 of 1		DO NOT SCALE THIS DOCUMENT	