

Notes:

- DISCHARGE MUFFLERS WILL BE SHIPPED LOOSE.
- WEIGHT OF DUPLEX MODULE W/ PANEL: 2,336 LBS
WEIGHT OF DUPLEX MODULE W/O PANEL: 2,291 LBS
200G TANK WEIGHT: 658 LBS
- ☒ INDICATES LIFTING POINT.
- DENOTES CENTER OF GRAVITY.

SYSTEM CONNECTIONS	
ID	DESCRIPTION
I	INLET LOCATION
D	DISCHARGE LOCATION
C	CONDENSATE DRAIN LOCATION
T	TANK DRAIN LOCATION

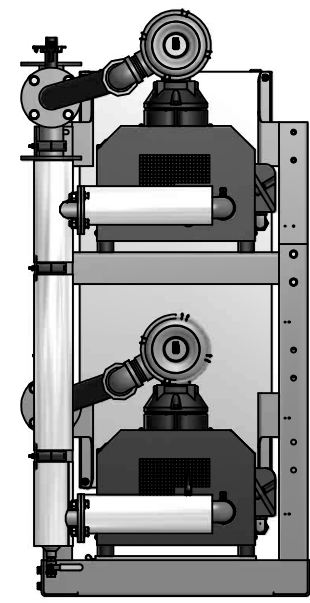
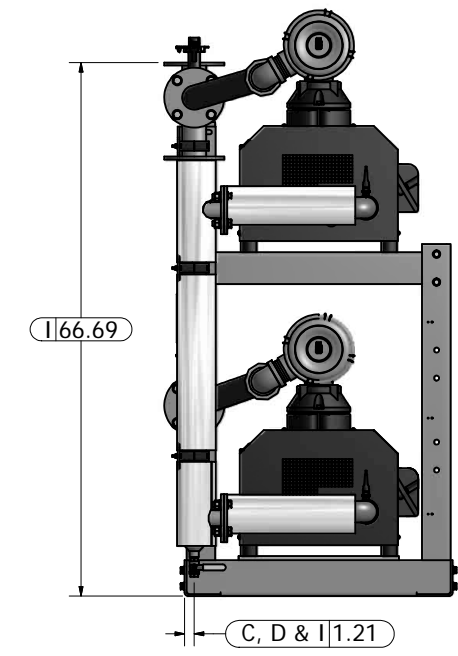
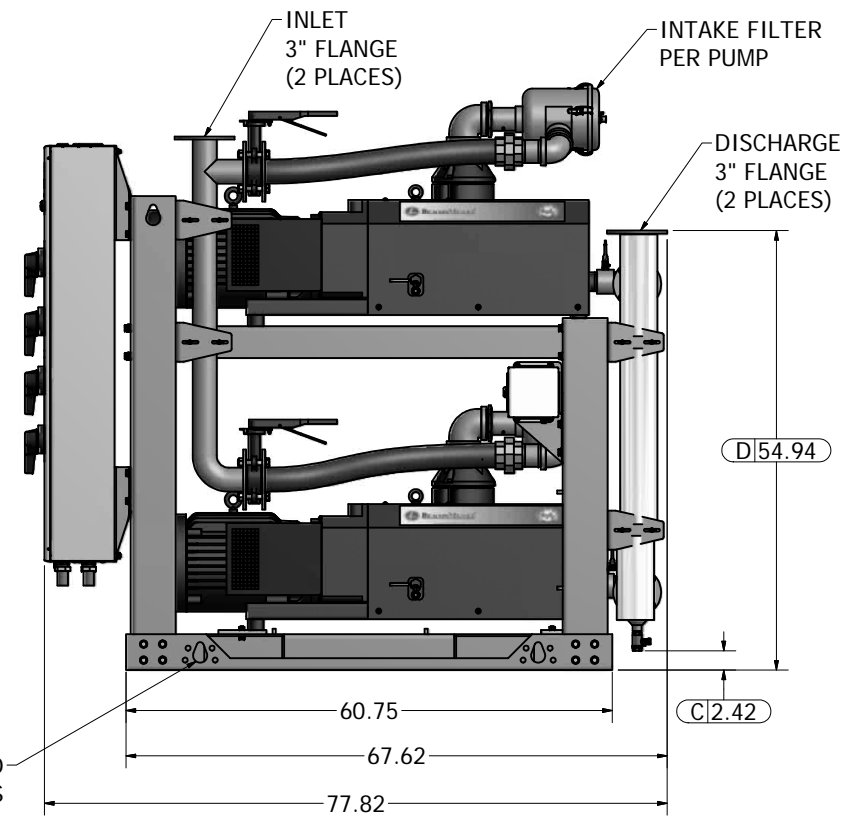
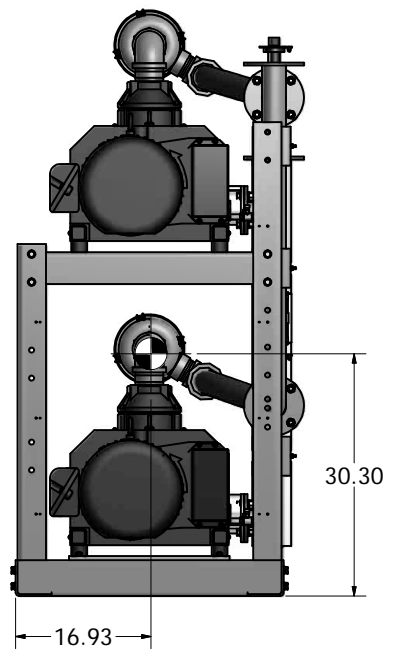
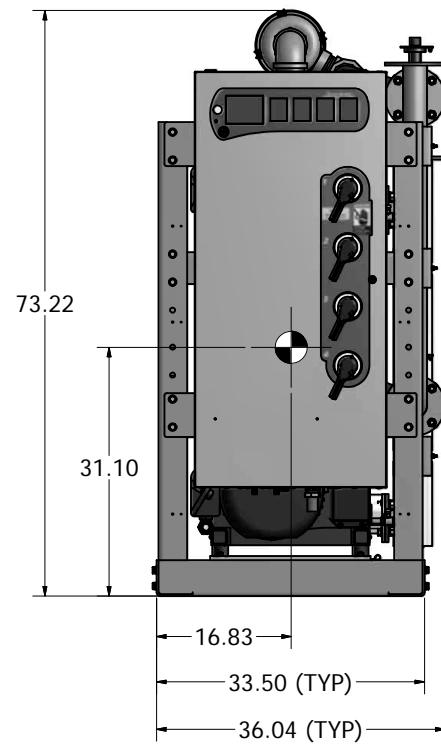
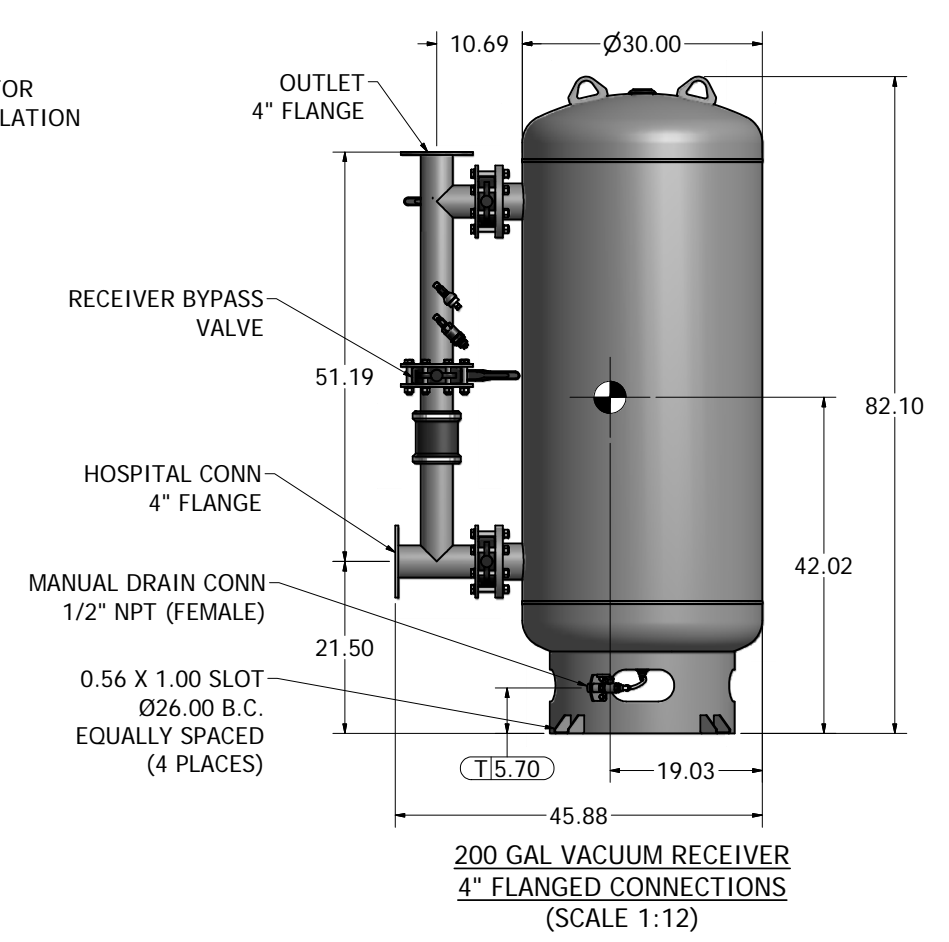
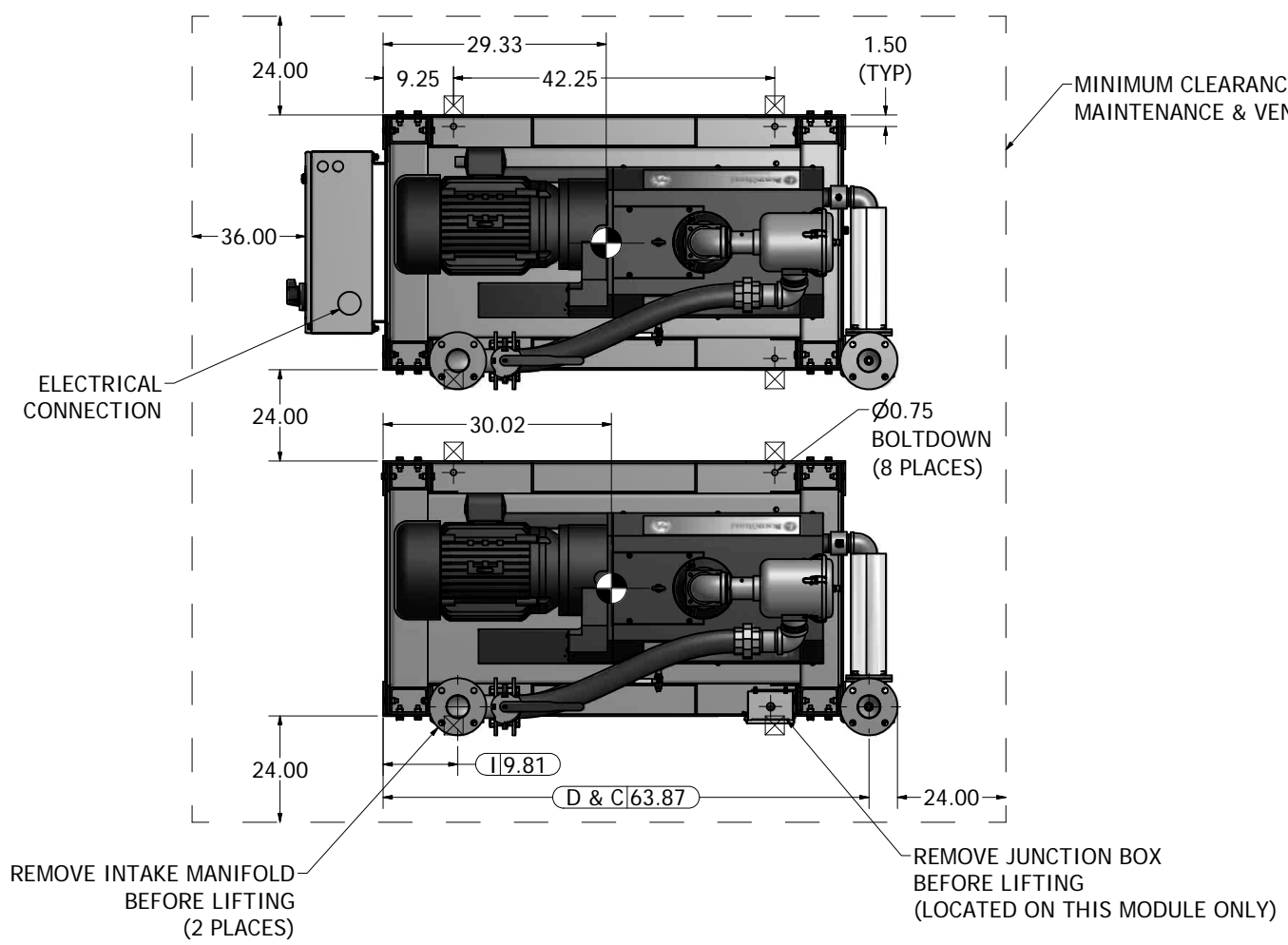

Revised:	Date:	Drawn:	Date:
		JWO	01/28/2014
		This drawing and the information contained therein remain the property of BeaconMedes and may not be used for other than the purpose for which it is loaned without the expressed written permission from BeaconMedes Engineering.	
Description: GENERAL ASSEMBLY 15HP OX CLAW VAC MOD 200G RECEIVER STANDARD		Part Number: 4107 8549 06	
DN: HOP131370		Rev: 00	
Sheet 1 of 1		DO NOT SCALE THIS DOCUMENT	