

- Notes:
- DISCHARGE MUFFLERS WILL BE SHIPPED LOOSE.
  - DUPLEX MODULE WITH CONTROL BOX WEIGHT: 2,287 LBS  
FUTURE SIMPLEX MODULE WEIGHT: 1,140 LBS  
200G TANK WEIGHT: 658 LBS
  - ☒ INDICATES LIFTING POINT.
  - DENOTES CENTER OF GRAVITY.

SYSTEM CONNECTIONS	
ID	DESCRIPTION
I	INLET LOCATION
D	DISCHARGE LOCATION
C	CONDENSATE DRAIN LOCATION
T	TANK DRAIN LOCATION

REMOVE JUNCTION BOX BEFORE LIFTING (LOCATED ON SX MODULE ONLY)

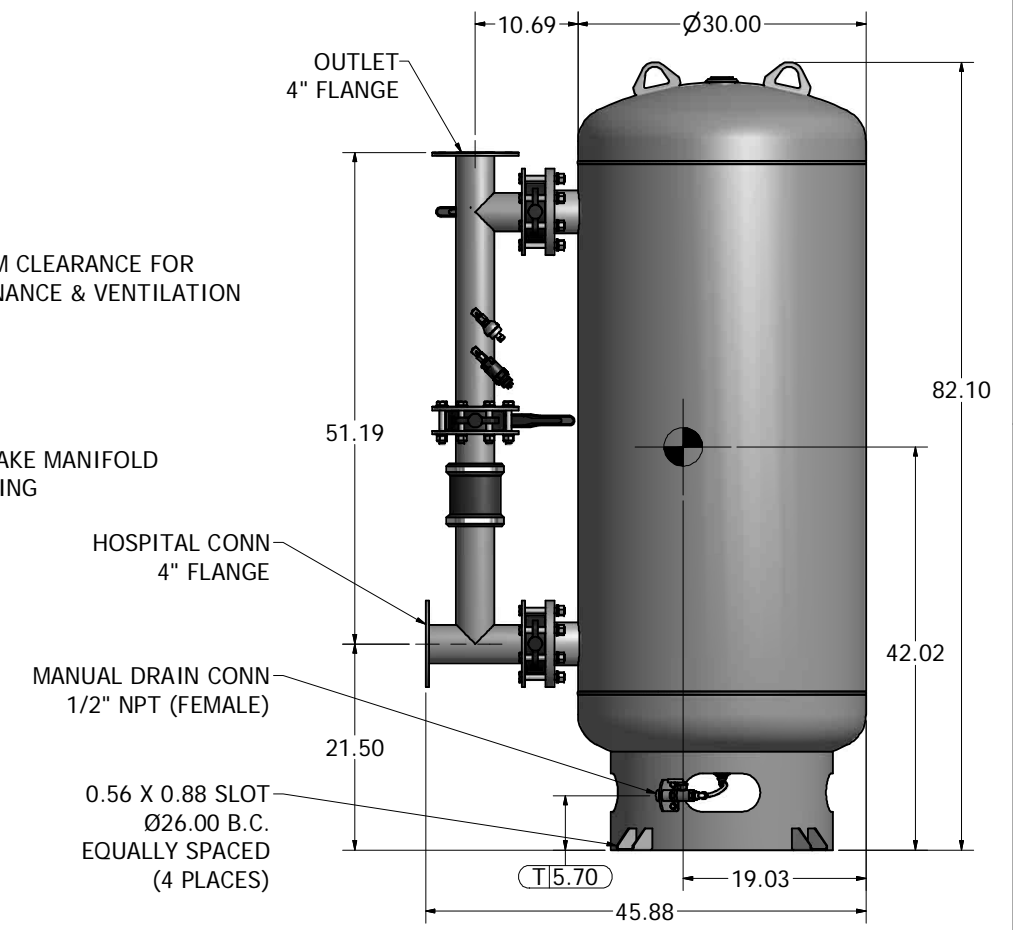
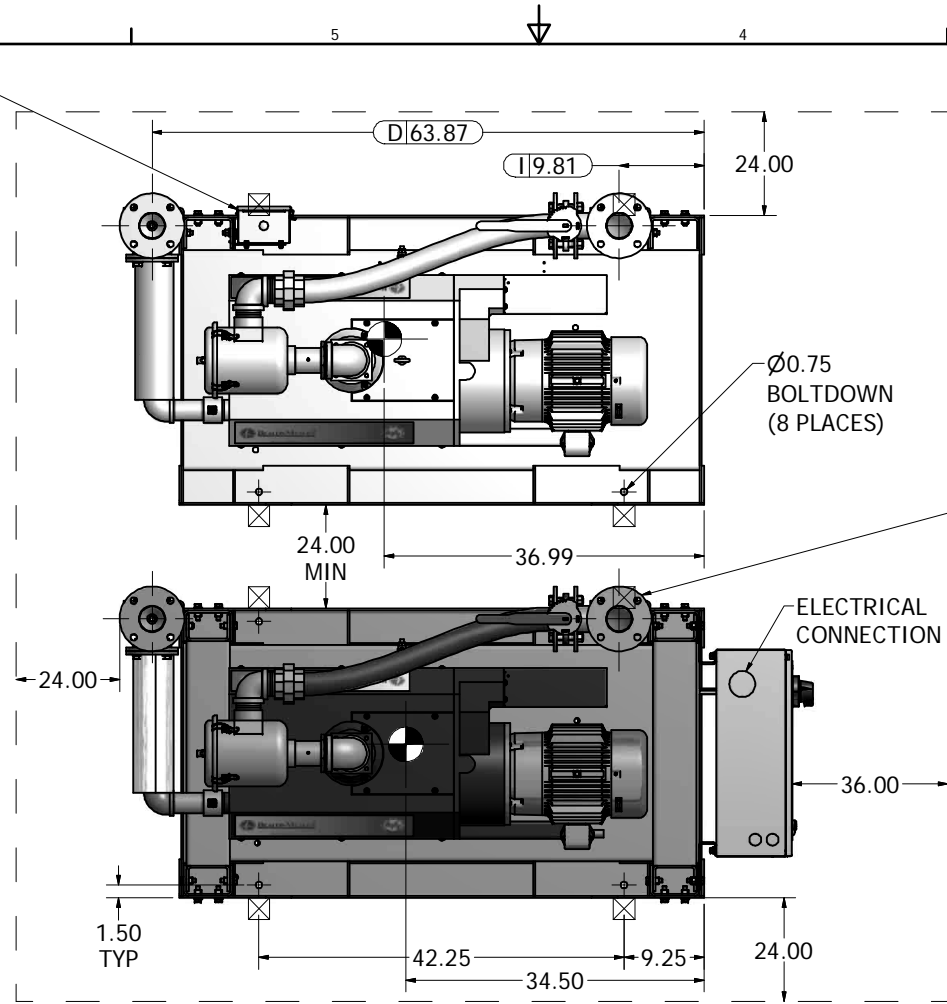

200 GAL VACUUM RECEIVER  
4" FLANGED CONNECTIONS  
(SCALE 1:10)

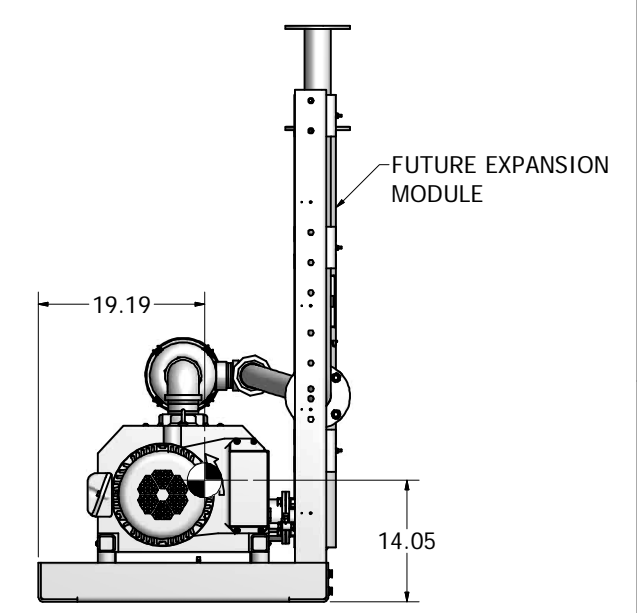
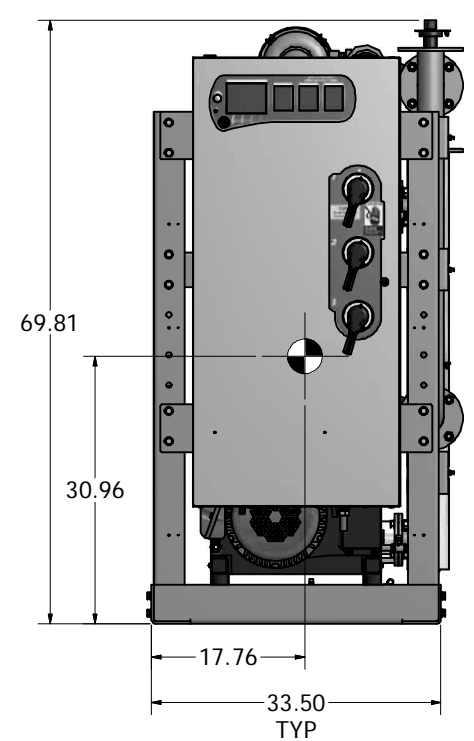
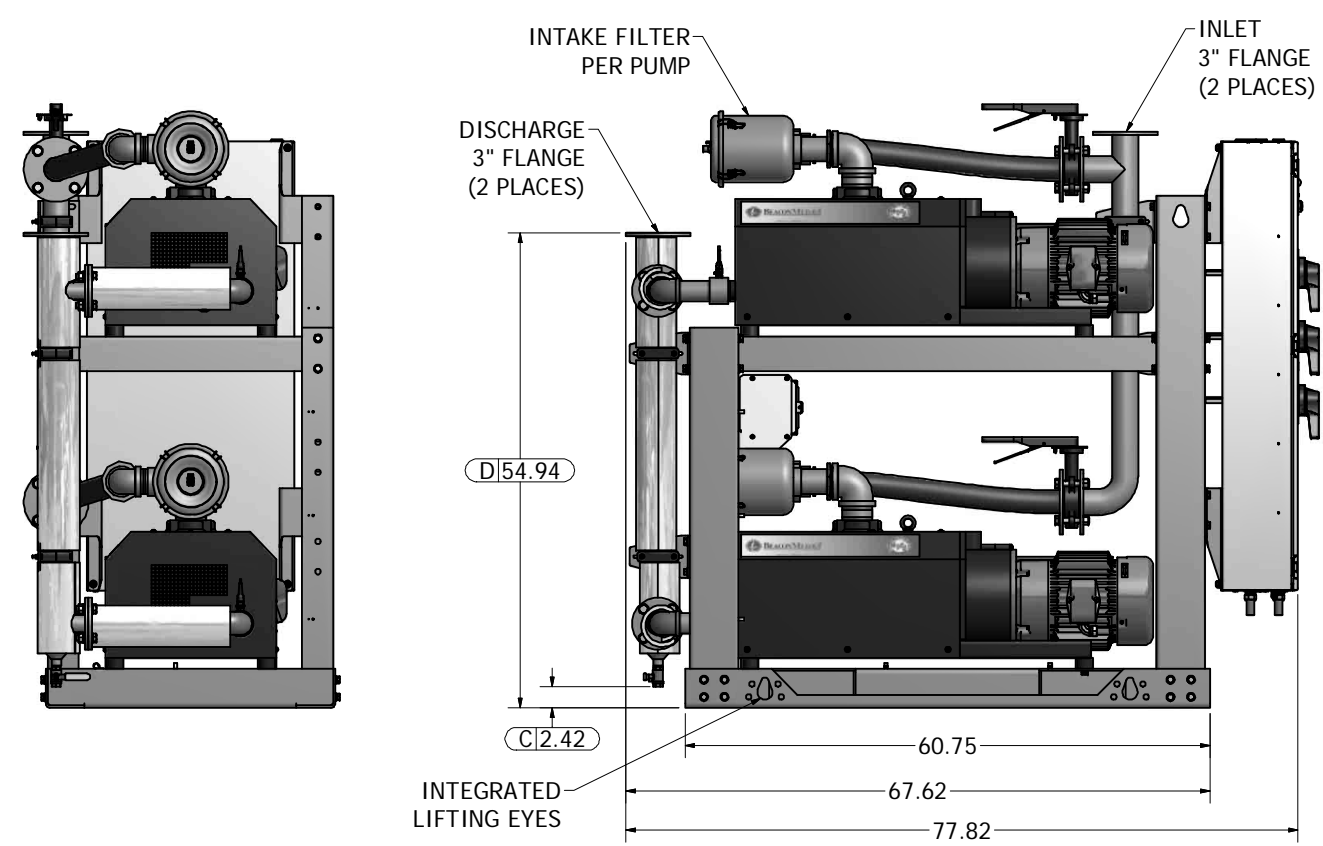
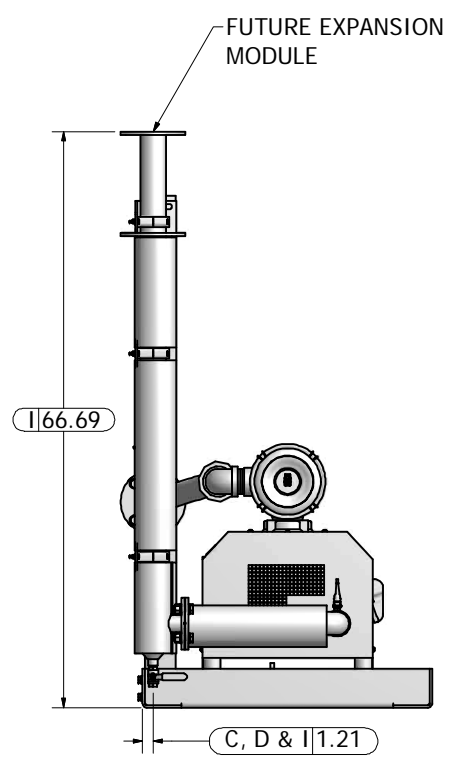

Revised:	Date:	Drawn: GTM	Date: 5/14/2012
		This drawing and the information contained therein remain the property of BeaconMedes and may not be used for other than the purpose for which it is loaned without the expressed written permission from BeaconMedes Engineering.	
Description: GENERAL ASSEMBLY 10HP DX-X-TX CLAW VAC MOD 200G RECEIVER STANDARD AND O2 ASSURED		Part Number: 4107 8539 18 Rev: HOP120412 00 Sheet 1 of 1	
Scale: 1/12 <b>D</b>		DO NOT SCALE THIS DOCUMENT	