

Notes:

- DISCHARGE MUFFLERS WILL BE SHIPPED LOOSE.
- WEIGHT OF DUPLEX MODULE W/ PANEL: 2,307 LBS  
WEIGHT OF DUPLEX MODULE W/O PANEL: 2,139 LBS  
240G TANK WEIGHT: 733 LBS
- ☒ INDICATES LIFTING POINT.
- DENOTES CENTER OF GRAVITY.

SYSTEM CONNECTIONS	
ID	DESCRIPTION
I	INLET LOCATION
D	DISCHARGE LOCATION
C	CONDENSATE DRAIN LOCATION
T	TANK DRAIN LOCATION

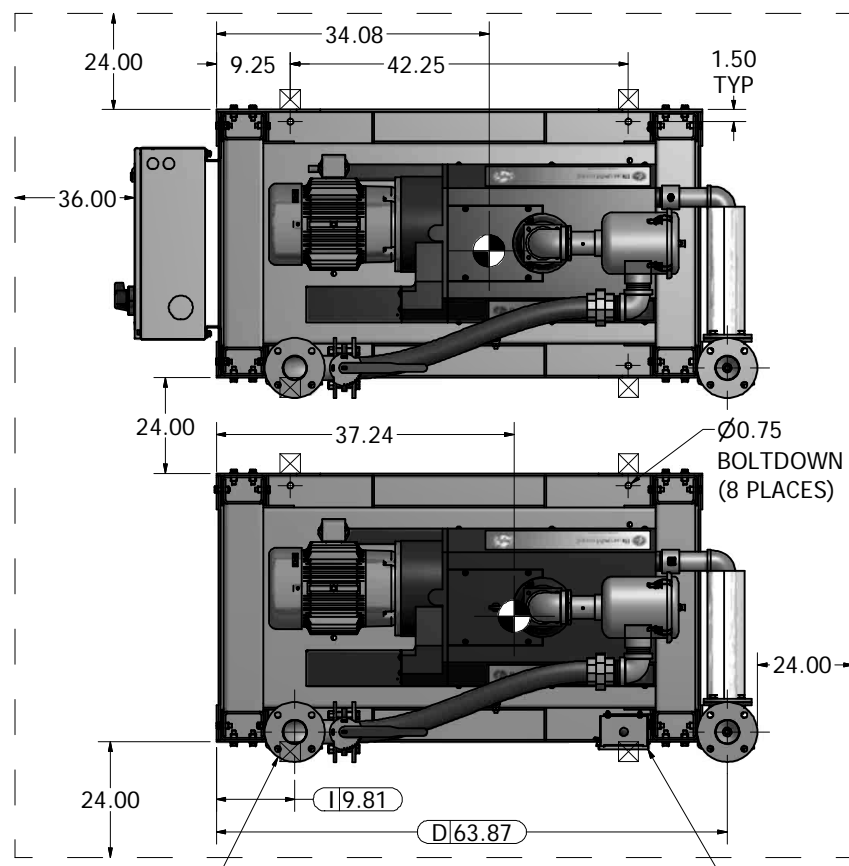

MINIMUM CLEARANCE FOR MAINTENANCE & VENTILATION

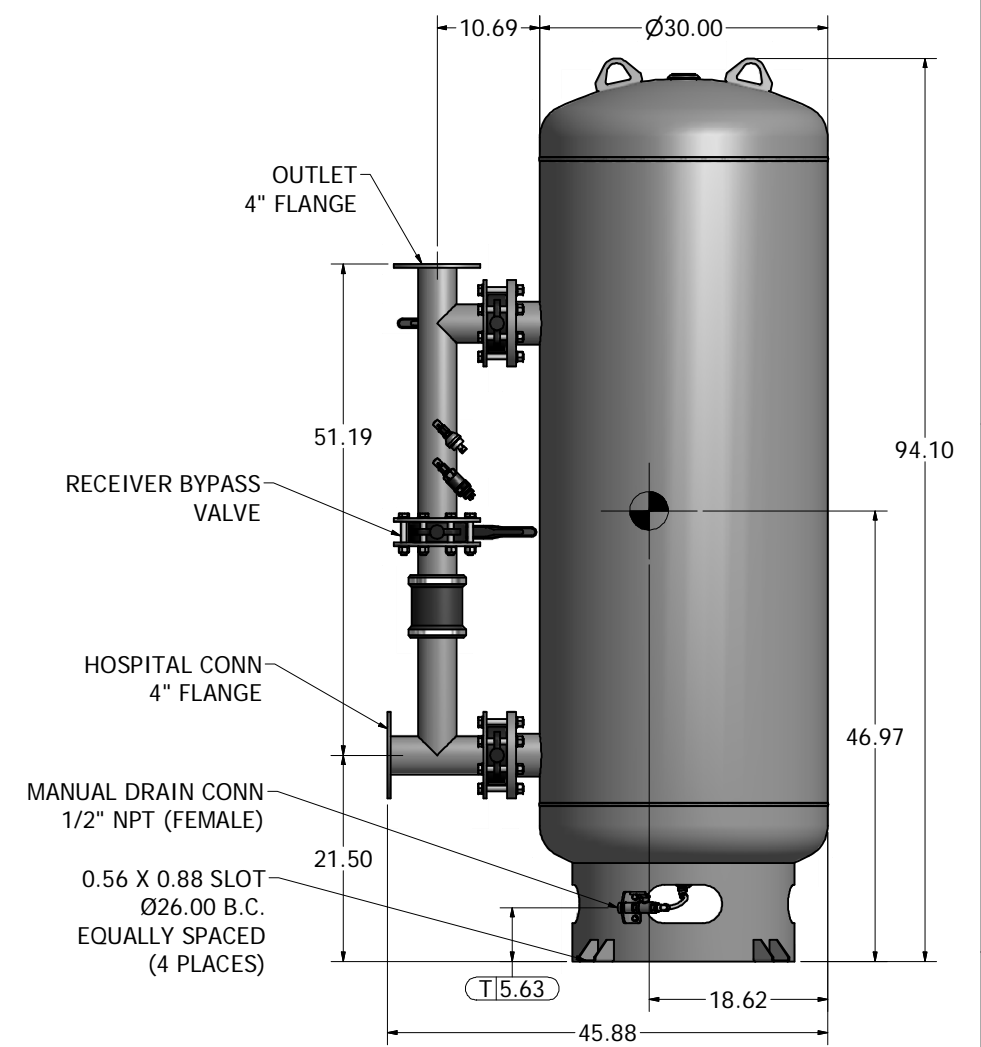

240 GAL VACUUM RECEIVER  
4\"/>

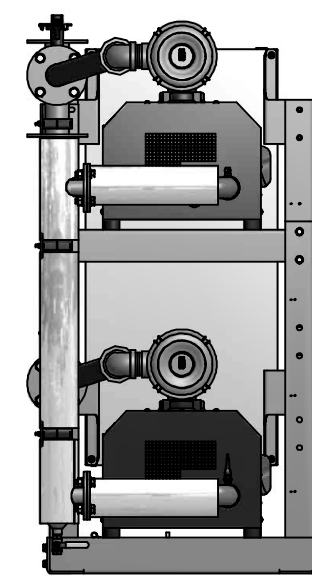
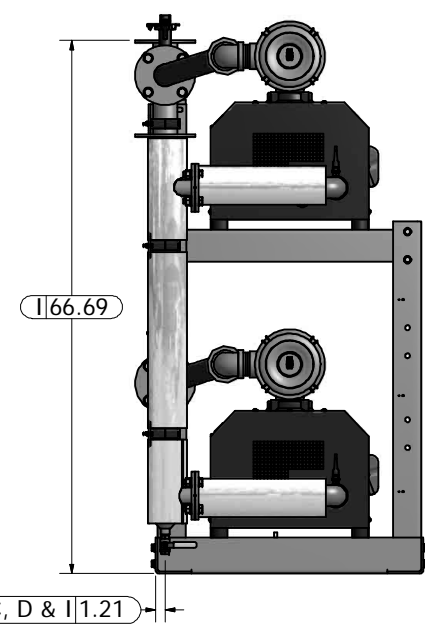
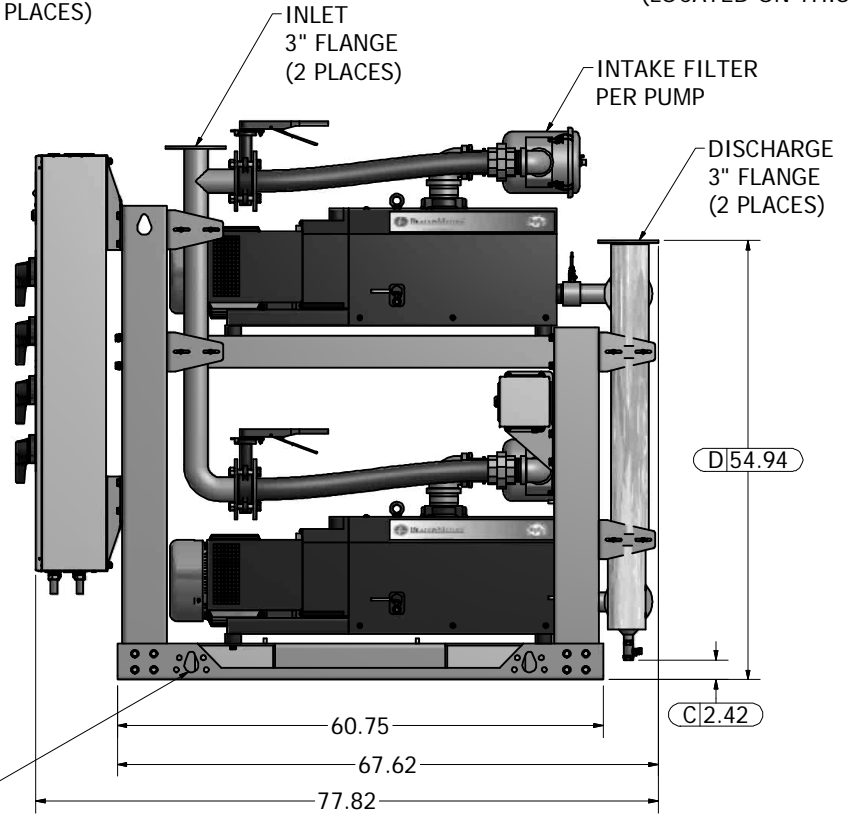
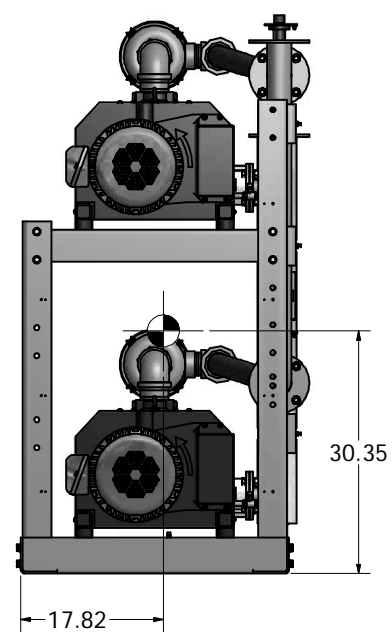
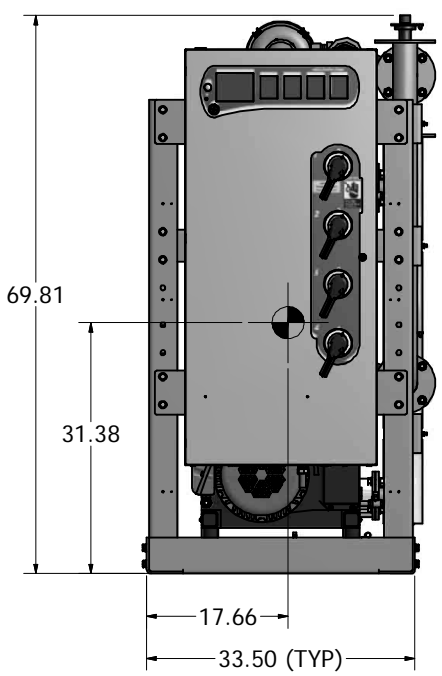

Revised:	Date:	Drawn:	Date:
		MDB	4/17/2012
		This drawing and the information contained therein remain the property of BeaconMedes and may not be used for other than the purpose for which it is loaned without the expressed written permission from BeaconMedes Engineering.	
Description: GENERAL ASSEMBLY 10HP OX CLAW VAC MOD 240G RECEIVER STANDARD AND O2 ASSURED		Part Number: 4107 8539 13	
DN: HOP120412		Rev: 00	
Sheet 1 of 1		DO NOT SCALE THIS DOCUMENT	