

Notes:

- DISCHARGE MUFFLERS & FLEX HOSES WILL BE SHIPPED LOOSE.
- DX MODULE WEIGHT: 2,252 LBS  
240G TANK WEIGHT: 713 LBS
- ⊠ INDICATES LIFTING POINT.
- DENOTES CENTER OF GRAVITY.

SYSTEM CONNECTIONS	
ID	DESCRIPTION
I	INLET LOCATION
D	DISCHARGE LOCATION
C	CONDENSATE DRAIN LOCATION
T	TANK DRAIN LOCATION

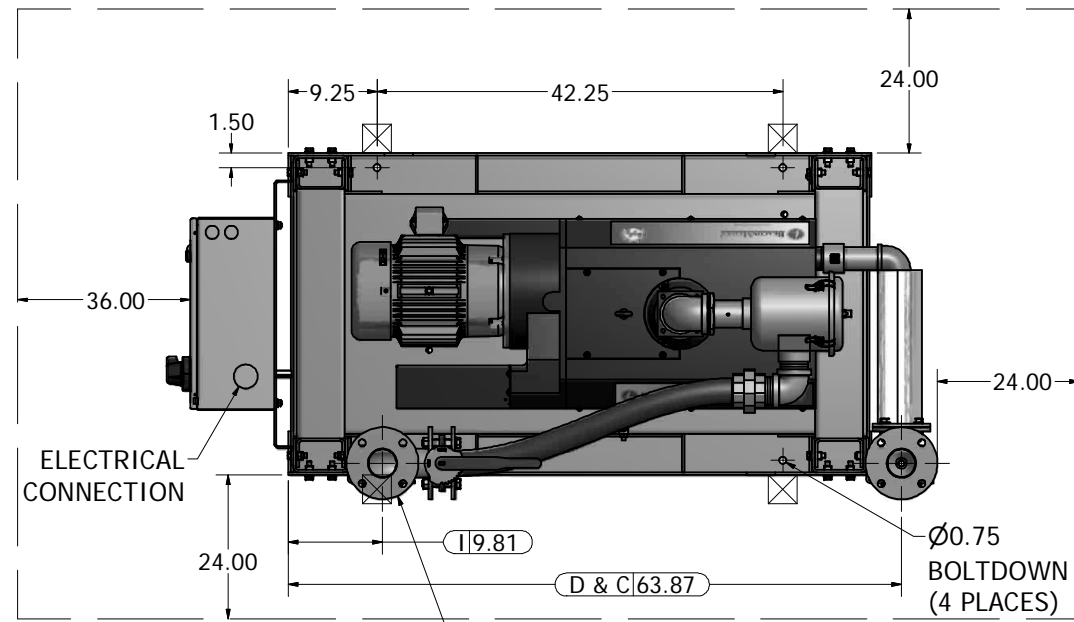

MINIMUM CLEARANCE FOR MAINTENANCE & VENTILATION

REMOVE INTAKE MANIFOLD BEFORE LIFTING

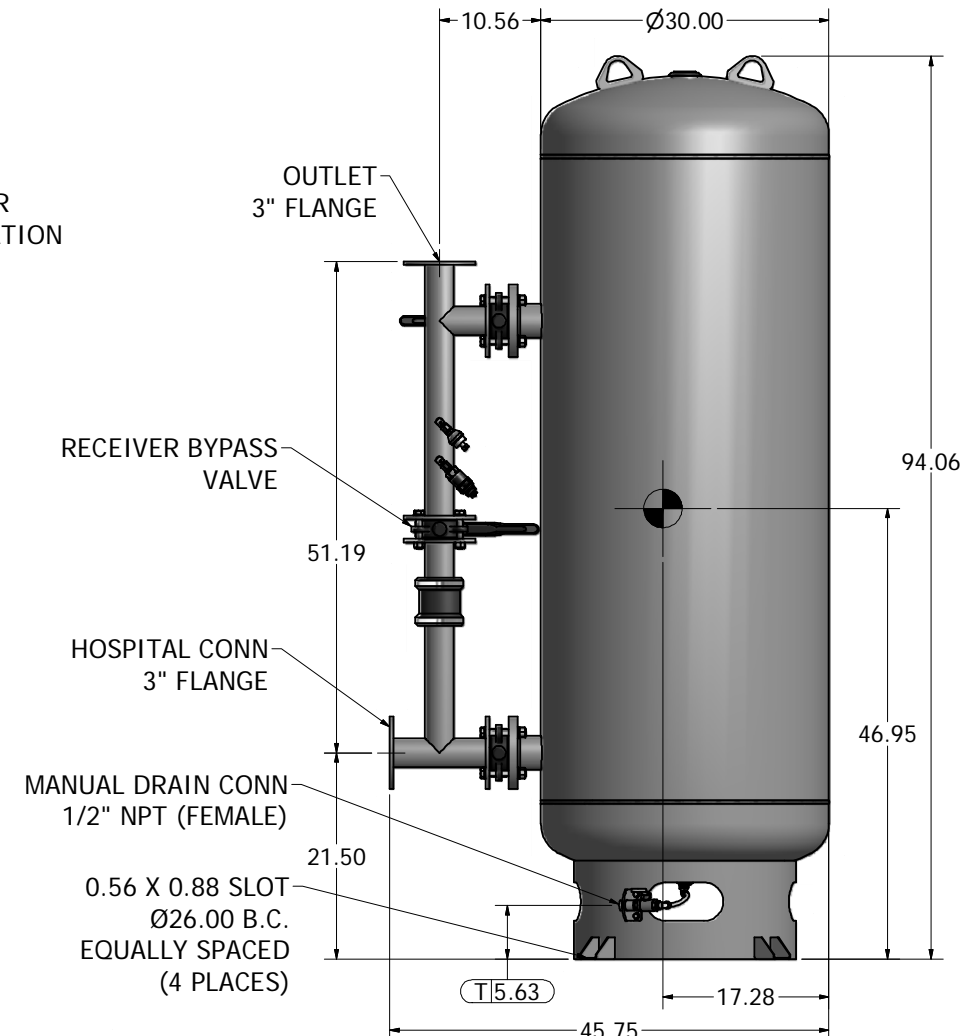

240 GAL VACUUM RECEIVER  
3" FLANGED CONNECTIONS  
(SCALE 1:10)

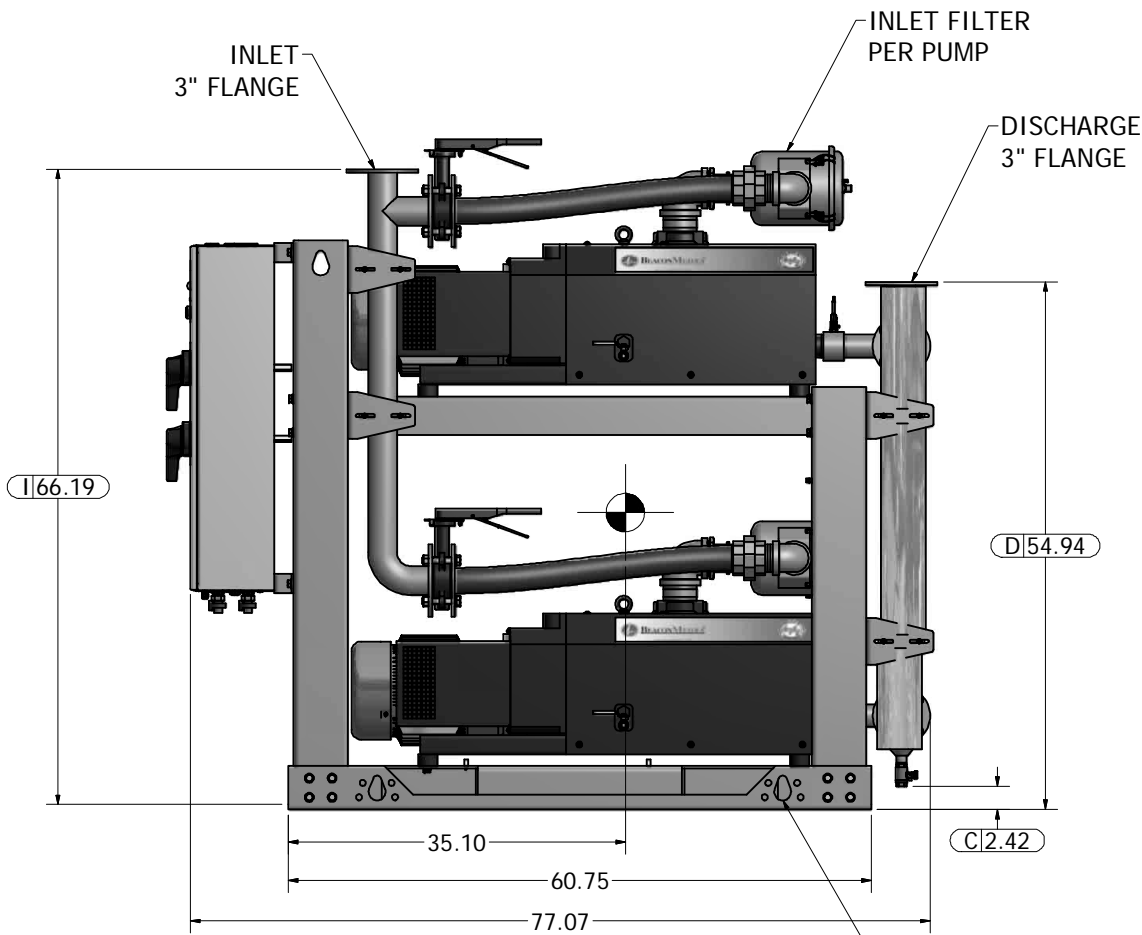
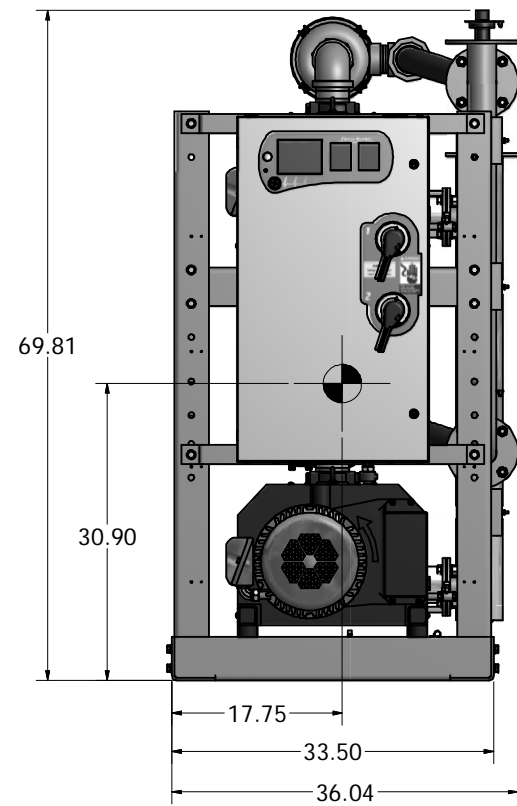

Revised:	Date:	Drawn:	Date:
		MDB	4/13/2012
		This drawing and the information contained therein remain the property of BeaconMedes and may not be used for other than the purpose for which it is loaned without the expressed written permission from BeaconMedes Engineering.	
Description: GENERAL ASSEMBLY 10HP DX CLAW VAC MOD 240G RECEIVER STANDARD AND O2 ASSURED		Part Number: 4107 8539 09	
DN: HOP120412		Rev: 00	
Sheet 1 of 1		DO NOT SCALE THIS DOCUMENT	