

Notes:

- DISCHARGE MUFFLER WILL BE SHIPPED LOOSE.
- TX MODULE WEIGHT: 2,647 LBS  
200G TANK WEIGHT: 638 LBS
- ☒ INDICATES LIFTING POINT.
- DENOTES CENTER OF GRAVITY.

SYSTEM CONNECTIONS	
ID	DESCRIPTION
I	INLET LOCATION
D	DISCHARGE LOCATION
C	CONDENSATE DRAIN LOCATION
T	TANK DRAIN LOCATION

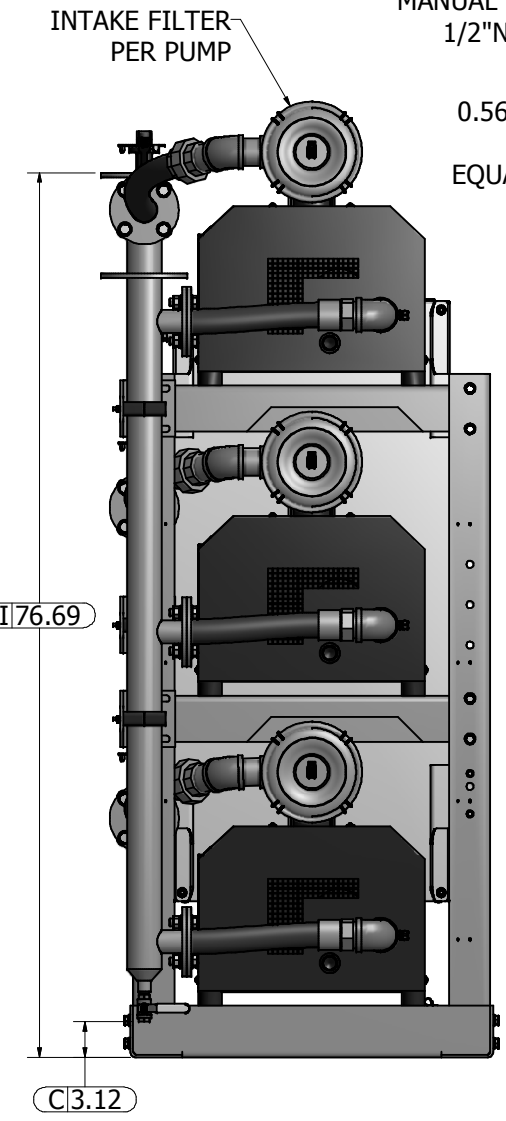
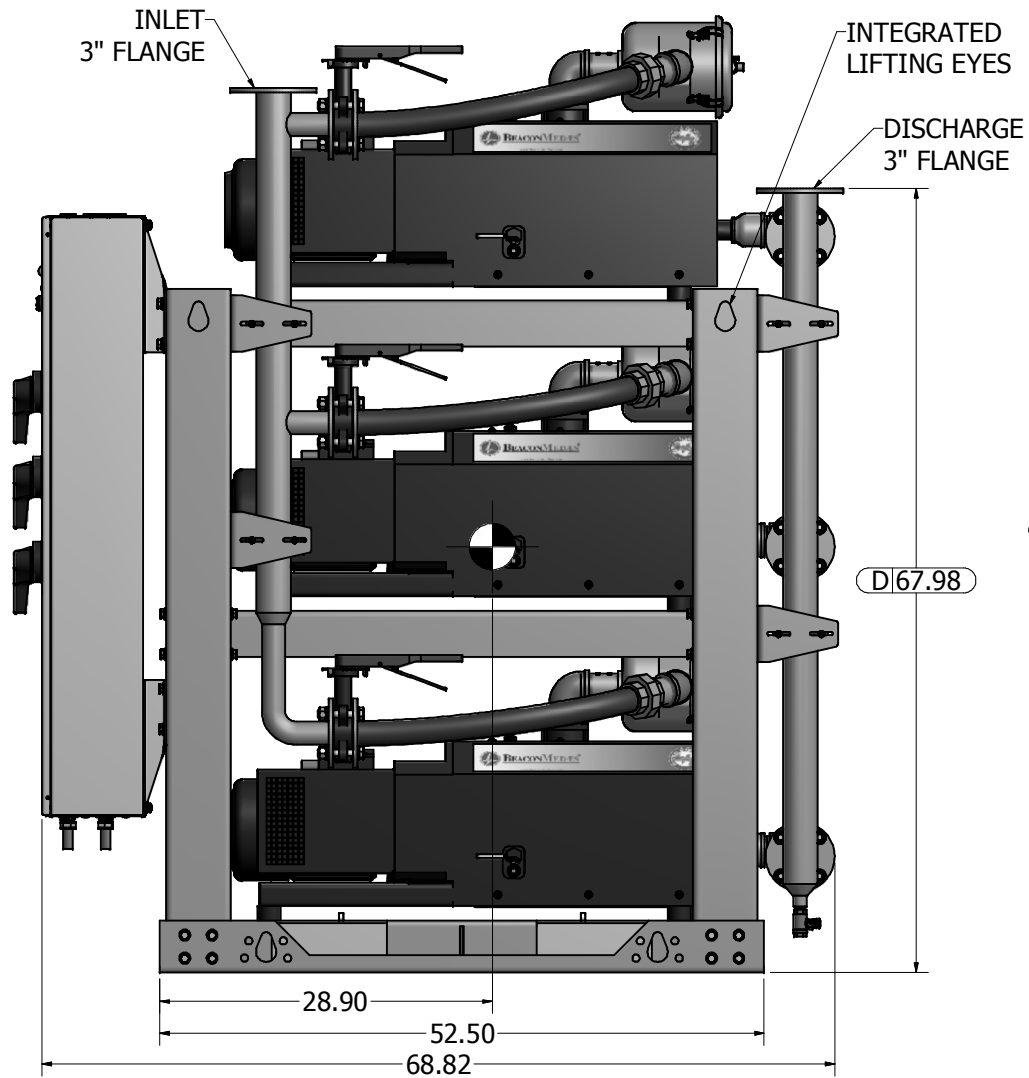
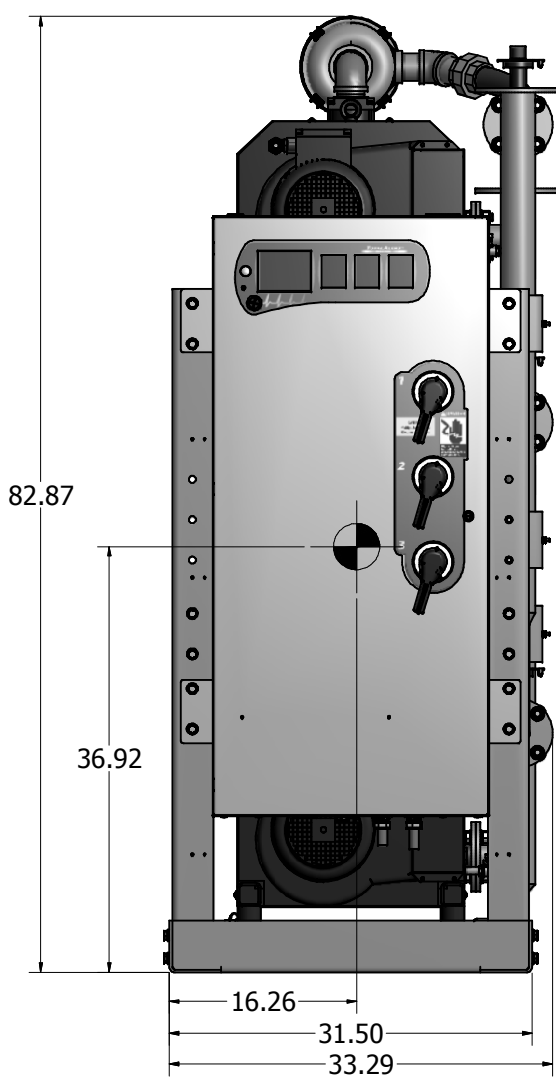
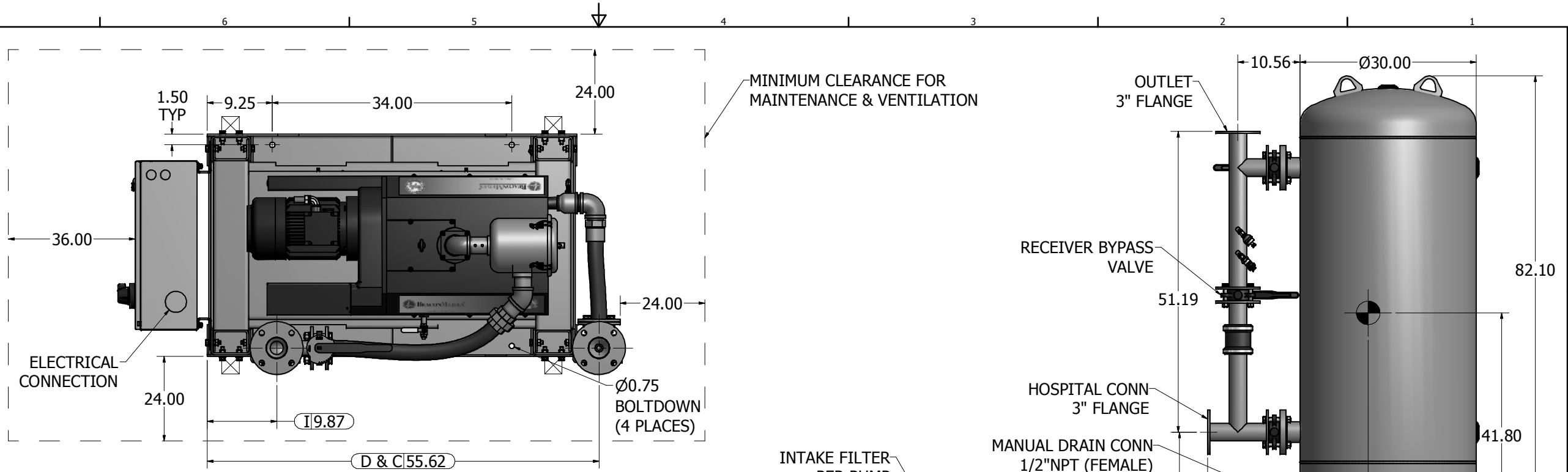

200 GAL VACUUM RECEIVER  
3" FLANGED CONNECTIONS  
(SCALE 1:10)

Revised:	Date:	Drawn: usnbw	Date: 3/31/2010
		This drawing and the information contained thereon remain the property of BeaconMedes and may not be used for other than the purpose for which it is loaned without the expressed written permission from BeaconMedes Engineering.	
Description: GENERAL ASSEMBLY 8.7HP TX CLAW VAC MOD 200G RECEIVER STANDARD AND O2 ASSURED		Part Number: 4107 8513 28 DN: USN100159 Rev: 00 Sheet 1 of 1 DO NOT SCALE THIS DOCUMENT	