

NOTES:

1. ALL INTERCONNECTING PIPE AND FITTINGS SHALL BE INSTALLED BY THE CONTRACTOR.
2. ALL PIPING SHALL BE INSTALLED IN ACCORDANCE WITH NFPA 99. PIPING LAYOUT IS DIAGRAMMATIC ONLY. FINAL ARRANGEMENT WILL BE SITE SPECIFIC. CONTRACTOR WILL BE RESPONSIBLE FOR FIELD VERIFICATION AND COORDINATING ACTUAL LOCATION WITH ALL OTHER TRADES.
3. CONTRACTOR SHALL VERIFY MOTOR VOLTAGE, PHASE AND AMP RATINGS BEFORE STARTING ELECTRICAL INSTALLATION; AND MAKE CERTAIN THE VOLTAGE SUPPLIED BY THE HOSPITAL IS THE SAME.
4. THE ROOM REQUIRES DEDICATED MECHANICAL VENTILATION WITH AN ALLOWABLE TEMPERATURE VARIANCE OF 40° TO 105°F. (FOR HIGHER AMBIENTS, CONSULT FACTORY)
5. ELECTRICAL POWER SHALL BE SUPPLIED FROM THE EQUIPMENT SYSTEM BRANCH OF THE ESSENTIAL ELECTRICAL SYSTEM (EMERGENCY POWER).
6. EQUIPMENT, INSTALLATION, AND TESTING OF THE MEDICAL VACUUM SYSTEM SHALL COMPLY WITH NFPA 99 AND ALL STATE AND LOCAL CODES OR ORDINANCES.
7. WIRE LAG PUMP RUNNING ALARM REMOTE CONTACTS IN THIS CONTROL SYSTEM TO MASTER ALARM SYSTEM AS REQUIRED BY NFPA 99.
8. ALL ACCESSORIES, PIPE AND FITTINGS, EXCEPT DISCHARGE SILENCERS BEYOND INLET AND DISCHARGE PORTS ARE SUPPLIED AND INSTALLED BY OTHERS.
9. WHEN DETERMINING THE TOTAL PIPE LENGTH, ADD ALL THE STRAIGHT LENGTHS OF PIPE TOGETHER IN ADDITION TO THE NUMBER OF ELBOWS TIMES THE THE EFFECTIVE PIPE LENGTH FOR THAT PIPE SIZE. (SEE EQUIVALENT PIPE LENGTH TABLE & EXAMPLE CALCULATION IN THE O&M MANUAL)

FOR INTAKE PIPE SIZING REFER TO STANDARD PRESSURE DROP TABLES. TOTAL PRESSURE DROP SHOULD BE LESS THAN 2" Hg AT A SYSTEM VACUUM LEVEL OF 15" Hg.

EXHAUST PIPE SIZE TABLE (SEE NOTE 9)			
UNIT SIZE	PIPE LENGTH		
	0-100'	101'-350'	351'-500'
QX 10	4.00" NPT	5.00" NPT	6.00" NPT

EFFECTIVE PIPE LENGTH FOR ELBOWS			
PIPE SIZE (IN)	4.00" NPT	5.00" NPT	6.00" NPT
	EFF. PIPE LENGTH (FT)	10	11.9

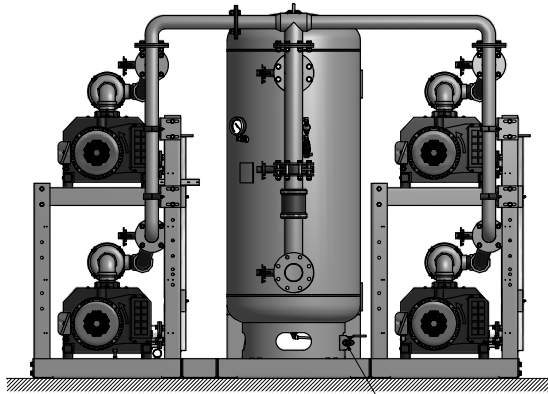
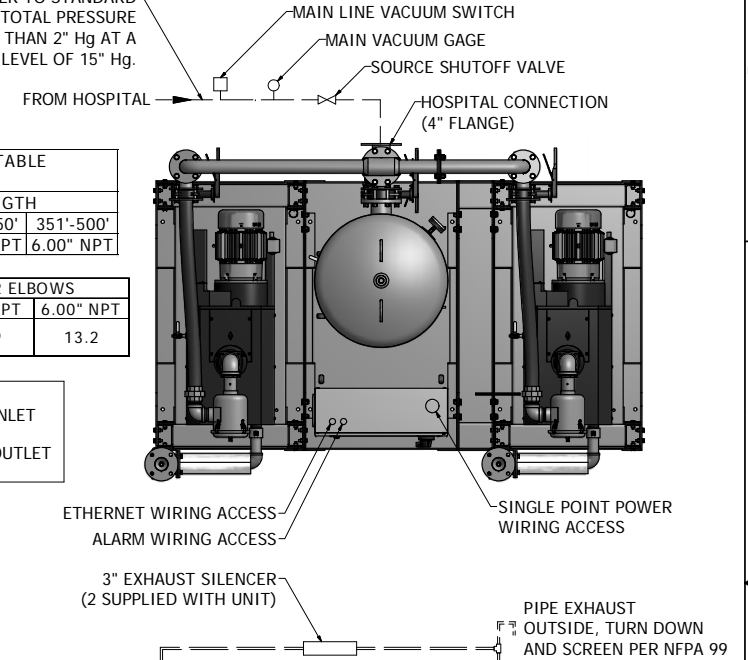
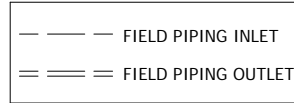

TANK DRAIN CONNECTION

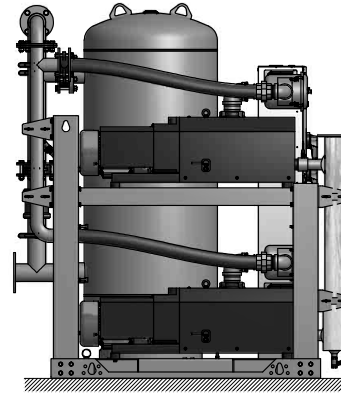

3" DISCHARGE FLANGE (2 PLACES)

NO FOUNDATION OR INERTIA PAD IS REQUIRED (HOUSEKEEPING PAD IS OPTIONAL)

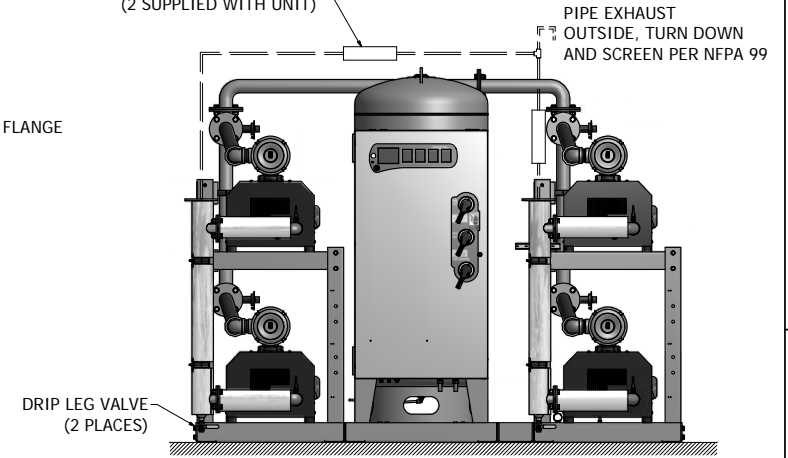

DRIP LEG VALVE (2 PLACES)

3" EXHAUST SILENCER (2 SUPPLIED WITH UNIT)

PIPE EXHAUST OUTSIDE, TURN DOWN AND SCREEN PER NFPA 99

(200 GALLON RECEIVER SHOWN)

Revised: CCC	Date: 6/26/2013	Drawn: GTM	Scale: 4:16/2012
			Circle: 1/11
<small>This drawing and the information contained therein remain the property of DragonMedes and may not be used for other than the purpose for which it is issued without the expressed written permission from DragonMedes Engineering.</small>			
Description: INSTALLATION DIAGRAM 10HP QX CLAW VAC VSD SPC STANDARD AND O2 ASSURED		Part Number: 4107 8539 01	Rev: 01
Sheet: 1 of 1		DO NOT SCALE THIS DRAWING	