

- NOTES:
- DISCHARGE MUFFLERS WILL BE SHIPPED LOOSE.
  - DX MODULE WEIGHT: 2,291 LBS.  
SX MODULE WEIGHT: 1,219 LBS  
(FUTURE EXPANSION MODULE).
  - 240G TANK WEIGHT: 733 LBS  
CONTROL PANEL WEIGHT: 257 LBS.
  - ☒ INDICATES LIFTING POINT.
  - DENOTES CENTER OF GRAVITY.

SYSTEM CONNECTIONS	
ID	DESCRIPTION
I	INLET LOCATION
D	DISCHARGE LOCATION
C	CONDENSATE DRAIN LOCATION
T	TANK DRAIN LOCATION

MINIMUM CLEARANCE FOR MAINTENANCE & VENTILATION

REMOVE INTAKE MANIFOLD BEFORE LIFTING (3 PLACES)

REMOVE JUNCTION BOX BEFORE LIFTING (3 PLACES)

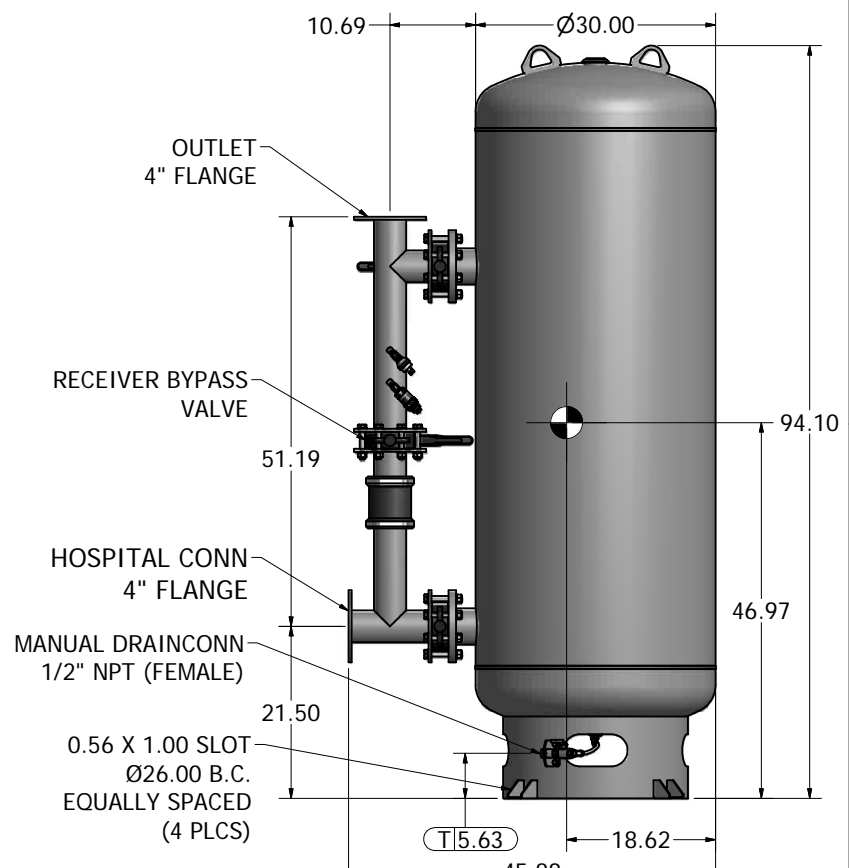
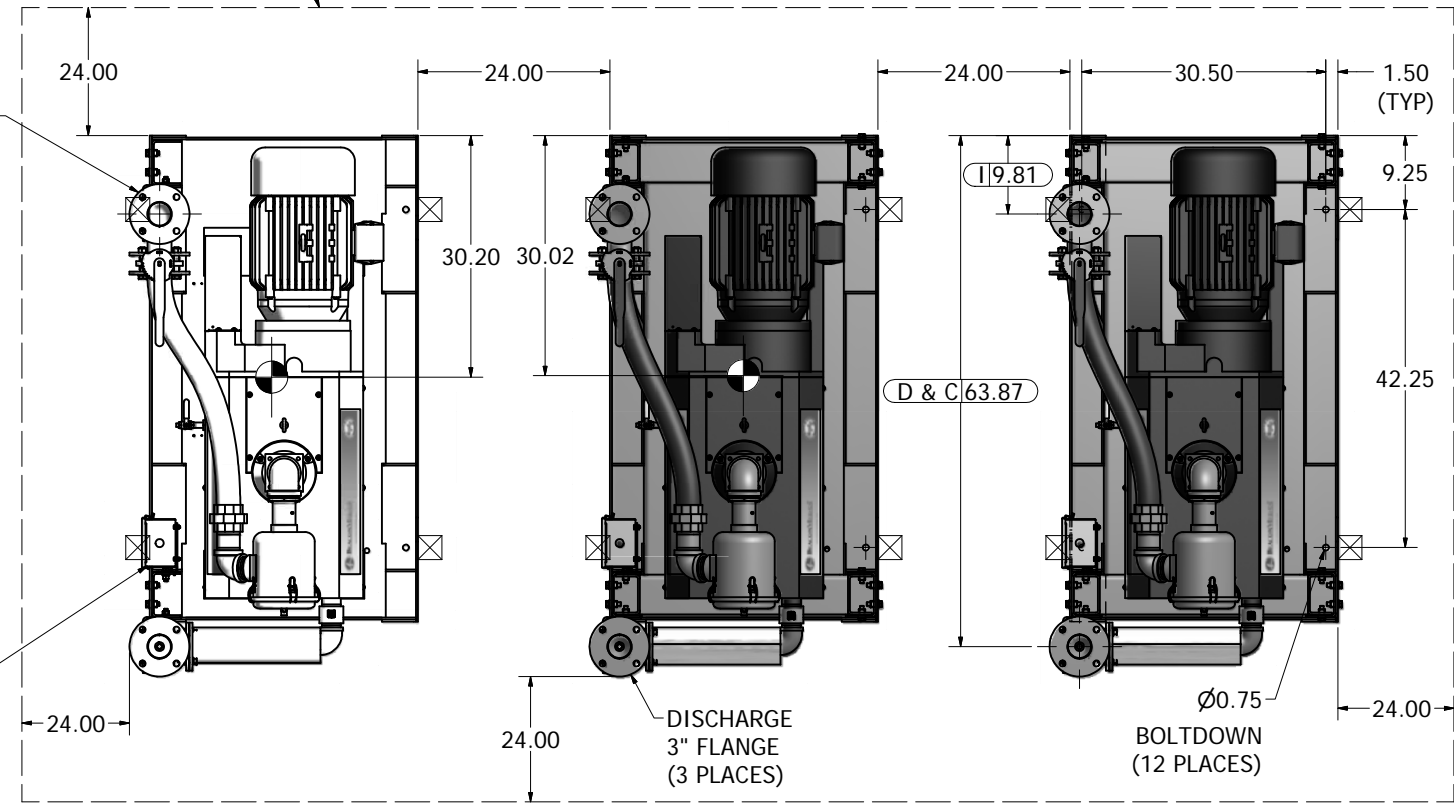

240 GAL VACUUM RECEIVER  
4" FLANGED CONNECTIONS  
(SCALE 1:12)

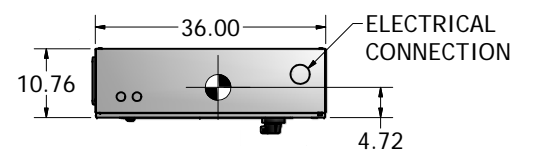
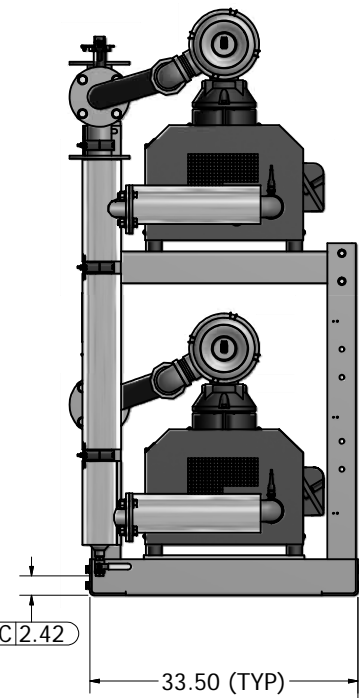
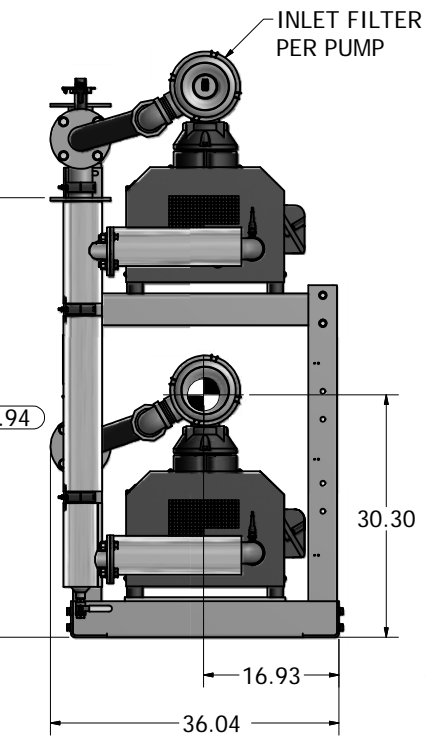
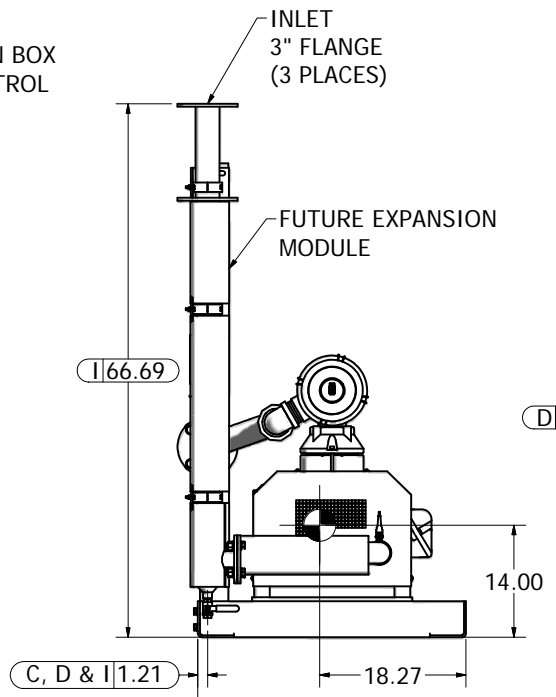
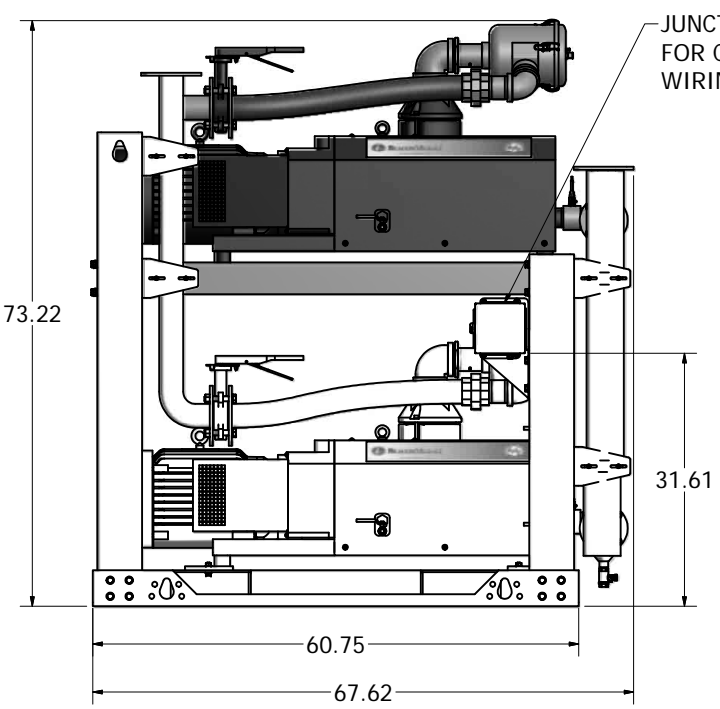

ALLOW 36" IN FRONT OF CONTROL PANEL FOR MAINTAINANCE

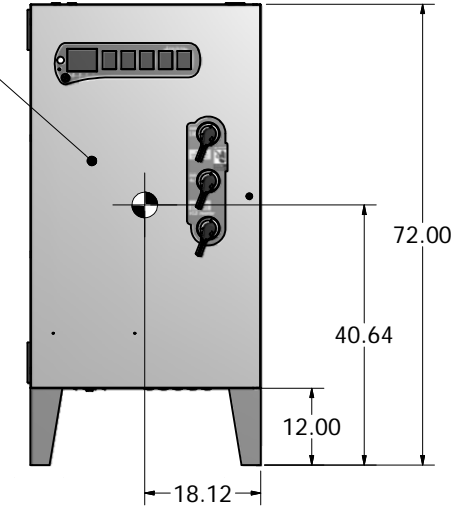

CONTROL PANEL

Revised:	Date:	Drawn: JWO	Date: 01/22/2014
		This drawing and the information contained therein remain the property of BeaconMedes and may not be used for other than the purpose for which it is loaned without the expressed written permission from BeaconMedes Engineering.	
Description: GENERAL ASSEMBLY 15HP OX-EXP-PX CLAW VSD VAC MOD 240G RECEIVER STANDARD		Part Number: 4107 8549 63 DN: HOP131370 Rev: 00 Sheet 1 of 1	
Scale: 1:12		DO NOT SCALE THIS DOCUMENT	