

- NOTES:
- DISCHARGE MUFFLERS WILL BE SHIPPED LOOSE.
 - DX MODULE WEIGHT: 2,291 LBS.
SX MODULE WEIGHT: 1,219 LBS.
(FUTURE EXPANSION MODULE)
 - 200G TANK WEIGHT: 658 LBS
CONTROL PANEL WEIGHT: 257 LBS.
 - ☒ INDICATES LIFTING POINT.
 - DENOTES CENTER OF GRAVITY.

SYSTEM CONNECTIONS	
ID	DESCRIPTION
I	INLET LOCATION
D	DISCHARGE LOCATION
C	CONDENSATE DRAIN LOCATION
T	TANK DRAIN LOCATION

MINIMUM CLEARANCE FOR MAINTENANCE & VENTILATION

REMOVE INTAKE MANIFOLD BEFORE LIFTING (3 PLACES)

REMOVE JUNCTION BOX BEFORE LIFTING (3 PLACES)

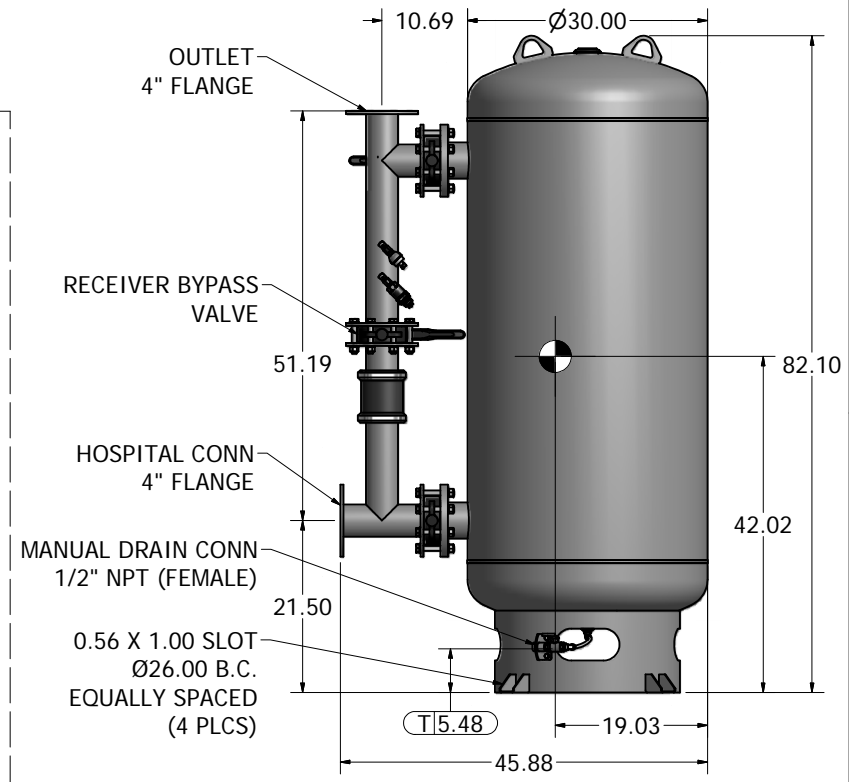
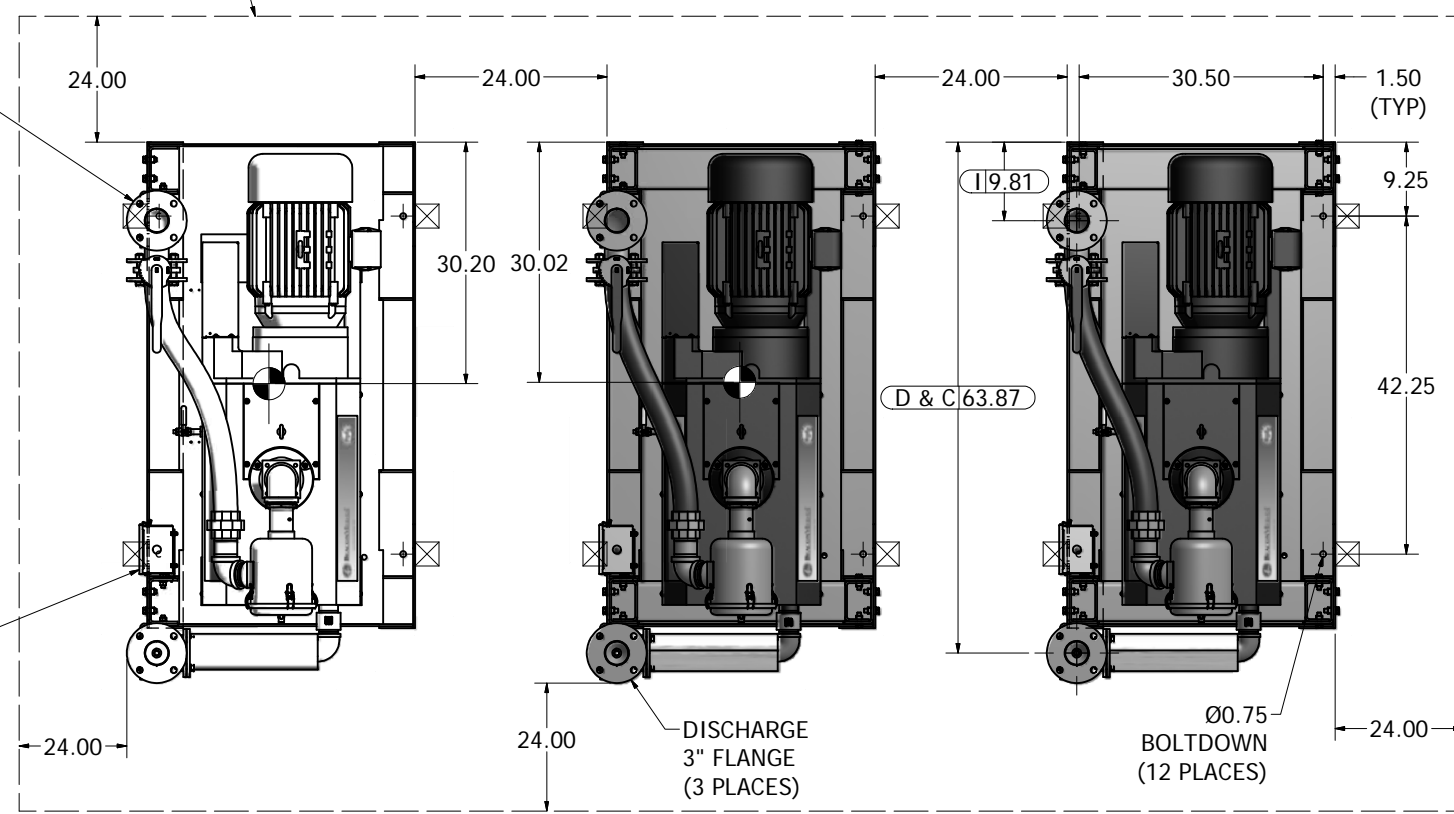

200 GAL VACUUM RECEIVER
4" FLANGED CONNECTIONS
(SCALE 1:12)

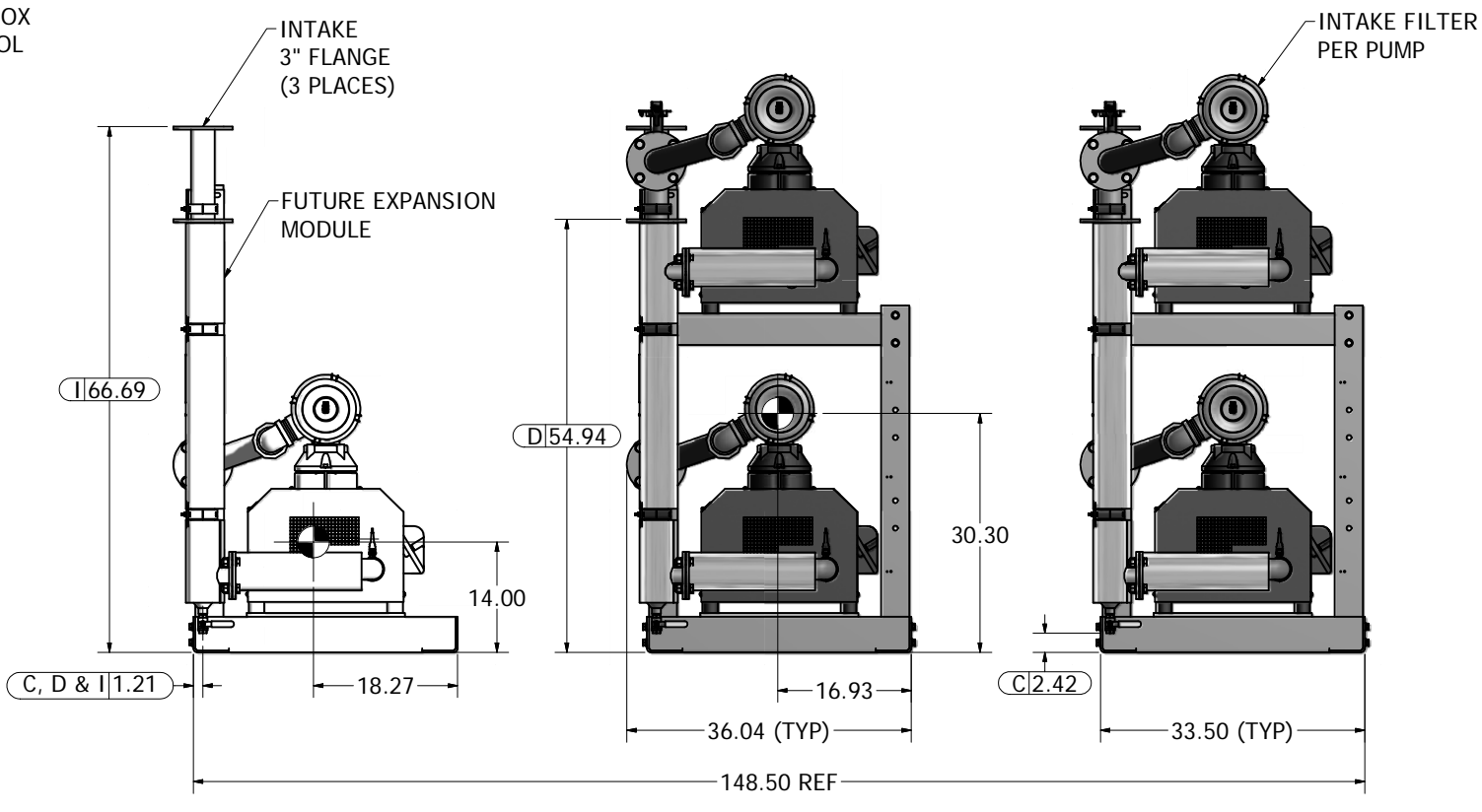
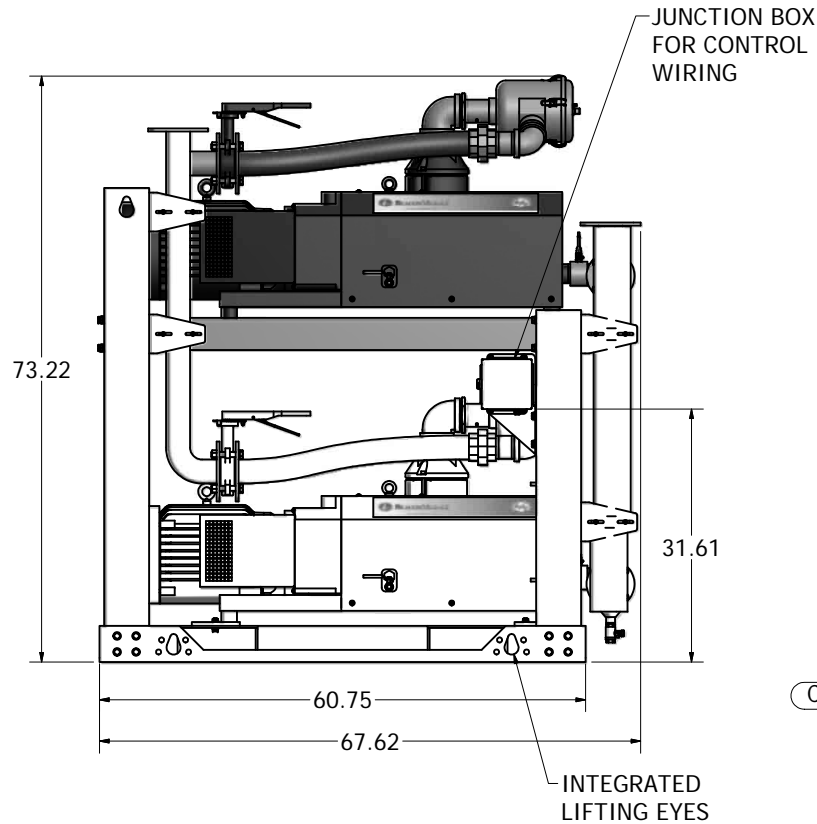
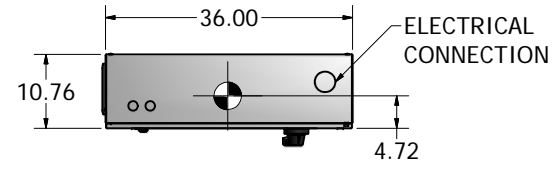

ALLOW 36" IN FRONT OF CONTROL PANEL FOR MAINTAINANCE

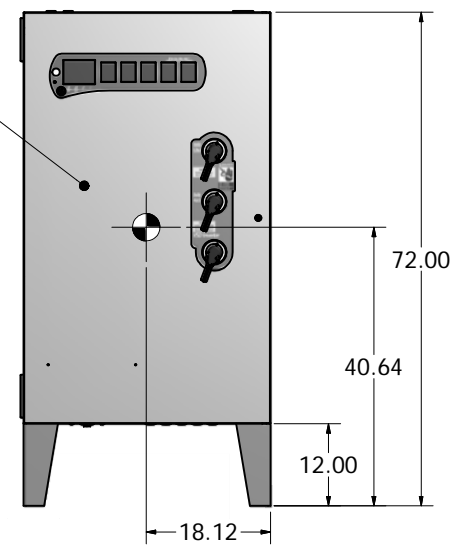

CONTROL PANEL

Revised:	Date:	Drawn:	Date:
		JWO	02/04/2014
		This drawing and the information contained therein remain the property of BeaconMedes and may not be used for other than the purpose for which it is loaned without the expressed written permission from BeaconMedes Engineering.	
Description:		Part Number:	
GENERAL ASSEMBLY 15HP QX-EXP-PX CLAW VSD VAC MOD 200G RECEIVER STANDARD		4107 8549 62	
DN:	Rev:		
1	00		
Sheet	1 of 1	DO NOT SCALE THIS DOCUMENT	