

Notes:

- DISCHARGE MUFFLERS WILL BE SHIPPED LOOSE.
- WEIGHT OF DUPLEX MODULE W/ PANEL: 2,414 LBS
WEIGHT OF DUPLEX MODULE W/O PANEL: 2,291 LBS (INCLUDES FUTURE EXPANSION PUMP)

240G TANK WEIGHT: 733 LBS
- ☒ INDICATES LIFTING POINT.
- DENOTES CENTER OF GRAVITY.

SYSTEM CONNECTIONS	
ID	DESCRIPTION
I	INLET LOCATION
D	DISCHARGE LOCATION
C	CONDENSATE DRAIN LOCATION
T	TANK DRAIN LOCATION

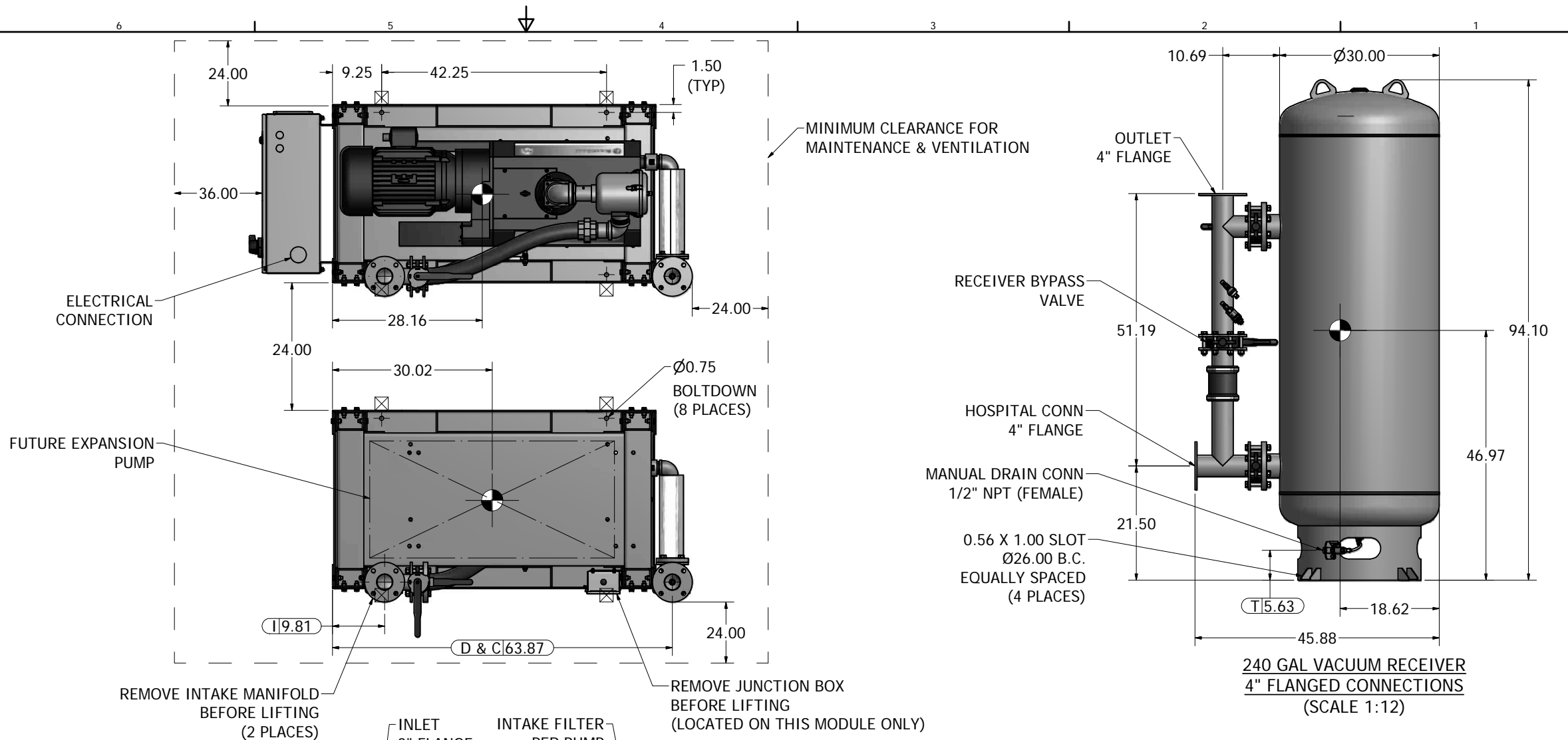

Revised:	Date:	Drawn:	Date:
		JWO	01/22/2014
		This drawing and the information contained therein remain the property of BeaconMedes and may not be used for other than the purpose for which it is loaned without the expressed written permission from BeaconMedes Engineering.	
Description: GENERAL ASSEMBLY 15HP TX-EXP-OX CLAW VSD VAC MOD 240G RECEIVER STANDARD		Part Number: 4107 8549 61 DN: HOP131370 Rev: 00 Sheet 1 of 1 DO NOT SCALE THIS DOCUMENT	