

Notes:

- DISCHARGE MUFFLER WILL BE SHIPPED LOOSE.
- WEIGHT OF DUPLEX MODULE W/ PANEL: 2,393 LBS
WEIGHT OF DUPLEX MODULE W/O PANEL: 1,219 LBS
200G TANK WEIGHT: 658 LBS
- ☒ INDICATES LIFTING POINT.
- DENOTES CENTER OF GRAVITY.

SYSTEM CONNECTIONS	
ID	DESCRIPTION
I	INLET LOCATION
D	DISCHARGE LOCATION
C	CONDENSATE DRAIN LOCATION
T	TANK DRAIN LOCATION

REMOVE JUNCTION BOX BEFORE LIFTING (LOCATED ON SX MODULE ONLY)

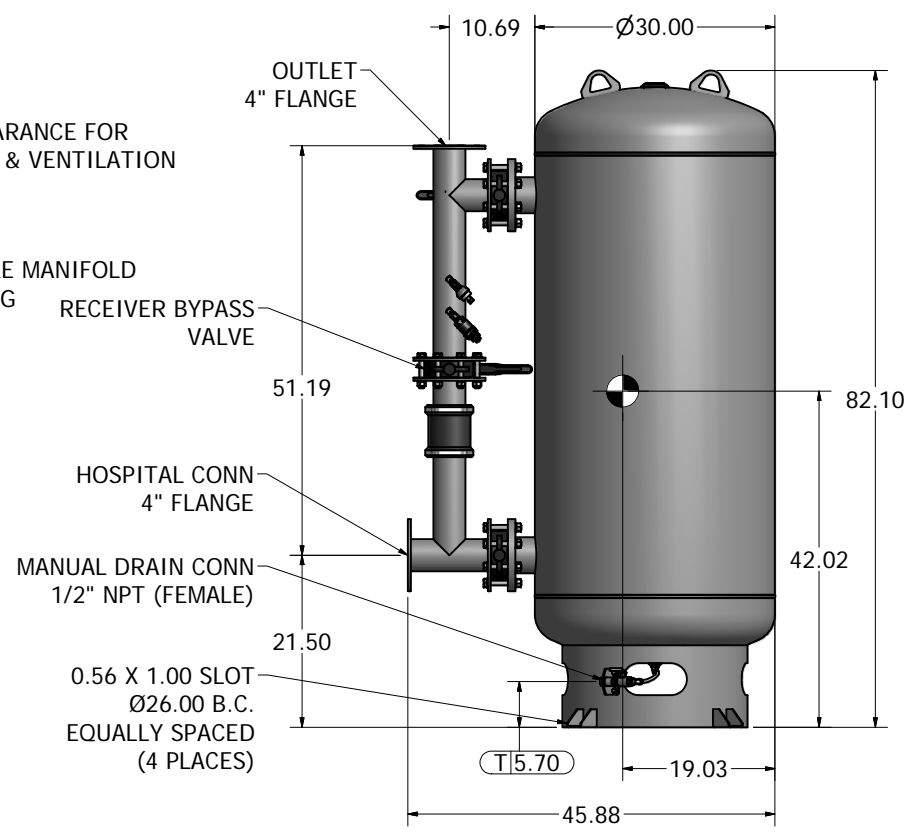
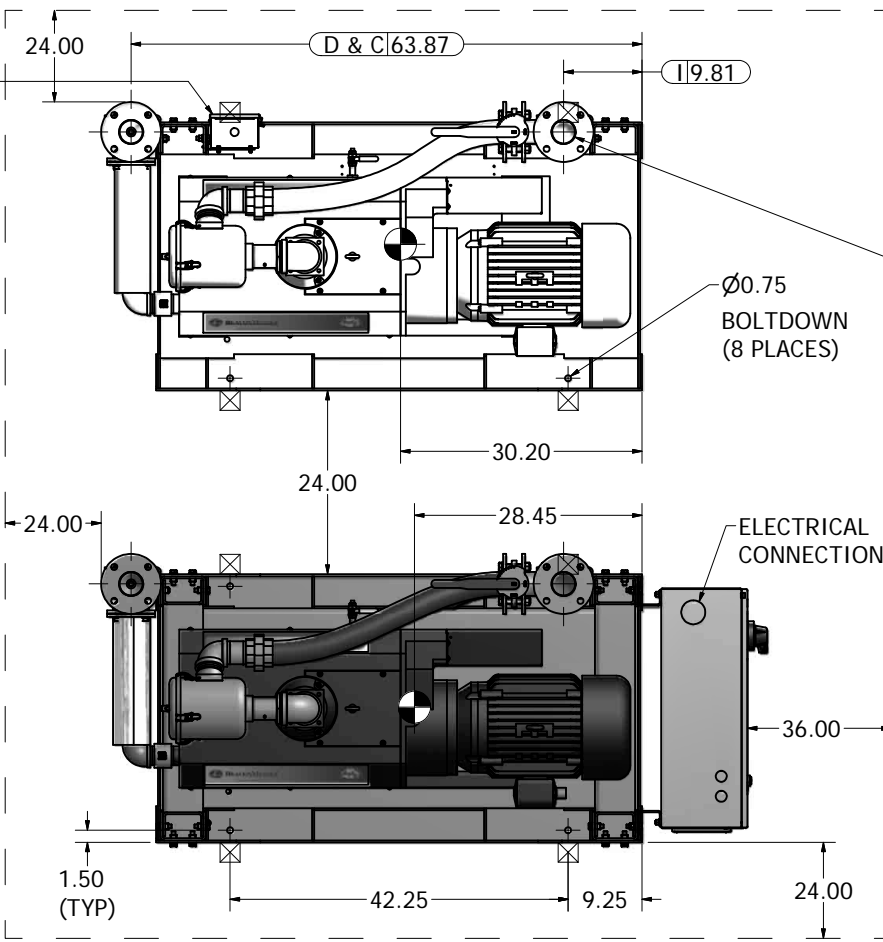

200 GAL VACUUM RECEIVER
4" FLANGED CONNECTIONS
(SCALE 1:12)

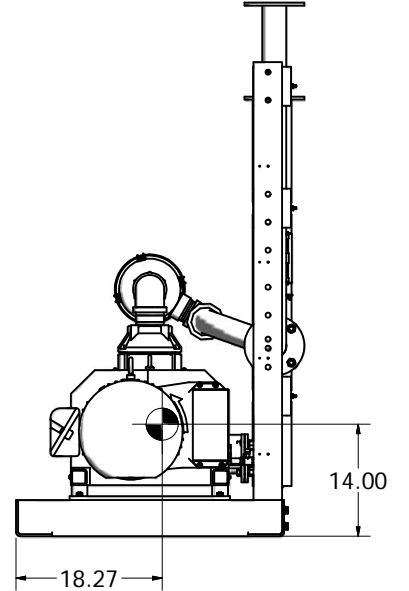
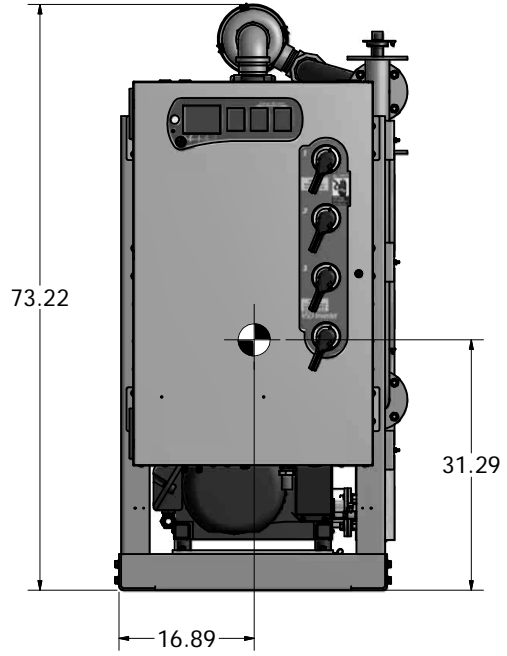
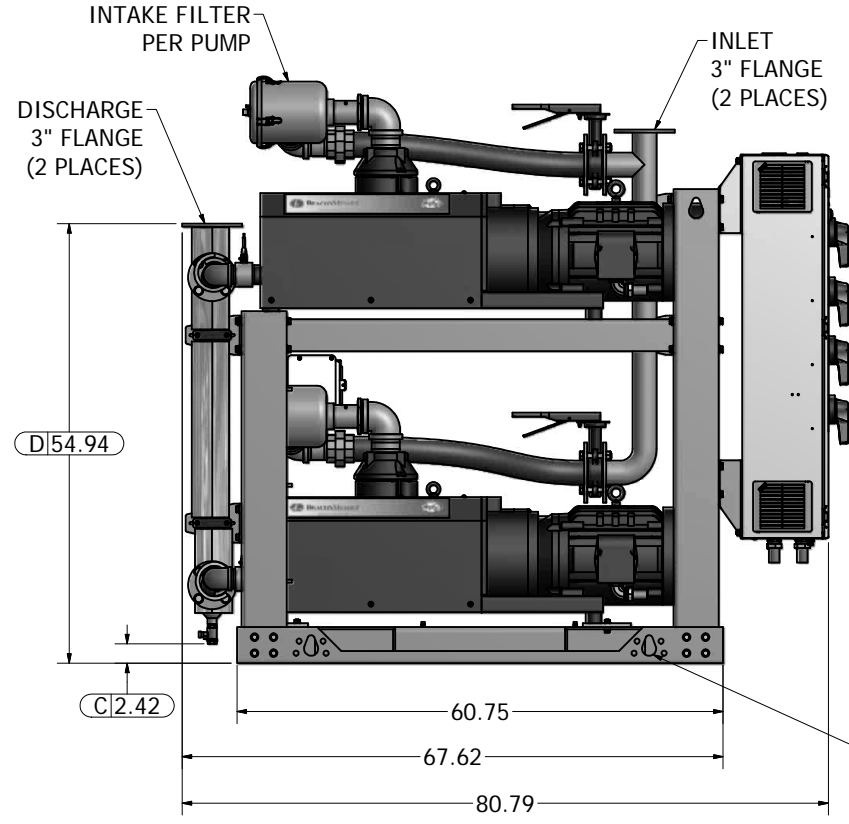
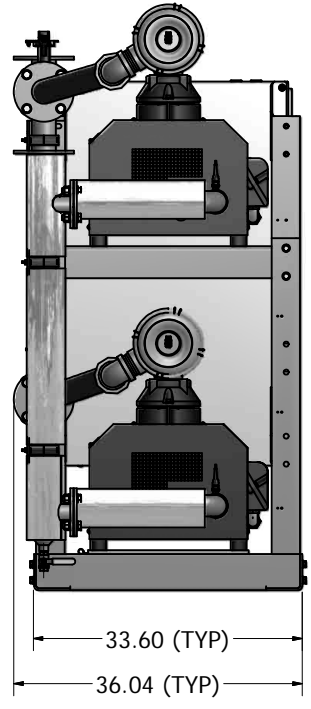
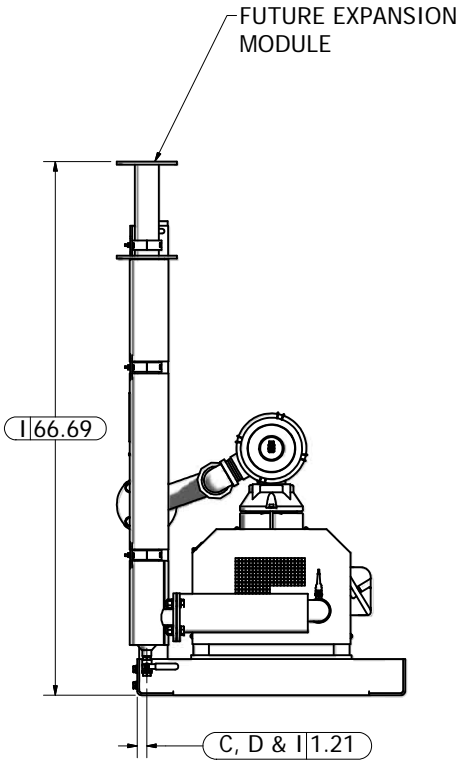

Revised:	Date:	Drawn:	Date:
		JWO	12/20/2013
		This drawing and the information contained therein remain the property of BeaconMedes and may not be used for other than the purpose for which it is loaned without the expressed written permission from BeaconMedes Engineering.	
Description: GENERAL ASSEMBLY 15 HP DX-EXP-TX CLAW VSD VAC MOD 200G RECIEVER STANDARD		Part Number: 4107 8549 58 DN: HOP131370 Rev: 00 Sheet 1 of 1	
		Scale: 1:12 DO NOT SCALE THIS DOCUMENT	