

- NOTES:
- DISCHARGE MUFFLERS WILL BE SHIPPED LOOSE.
 - DX MODULE WEIGHT: 2,291 LBS.
SX MODULE WEIGHT: 1,219 LBS
240G TANK WEIGHT: 733 LBS
CONTROL PANEL WEIGHT: 257 LBS.
 - ☒ INDICATES LIFTING POINT.
 - DENOTES CENTER OF GRAVITY.

SYSTEM CONNECTIONS	
ID	DESCRIPTION
I	INLET LOCATION
D	DISCHARGE LOCATION
C	CONDENSATE DRAIN LOCATION
T	TANK DRAIN LOCATION

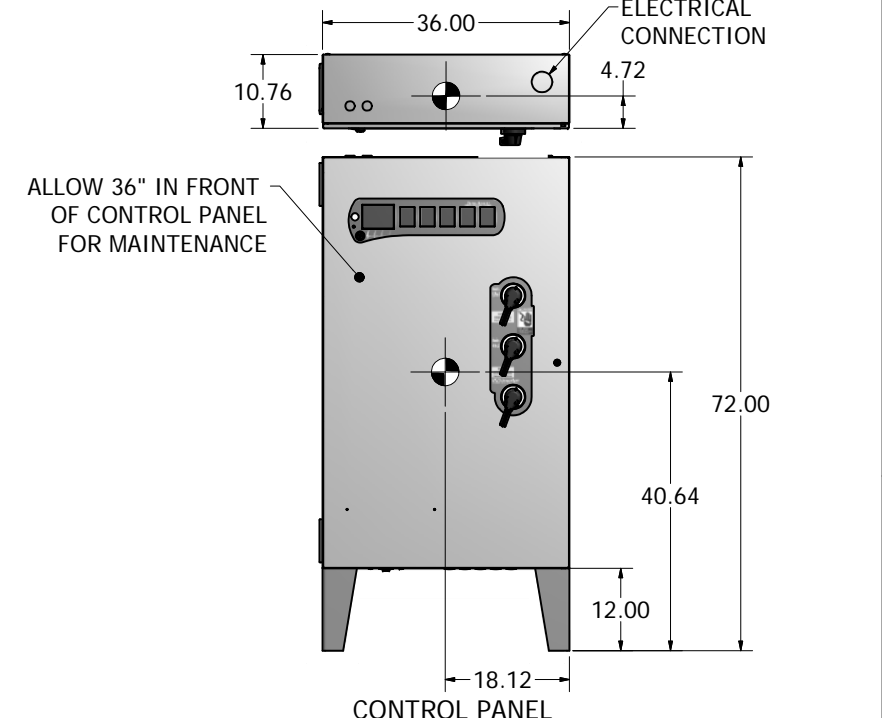
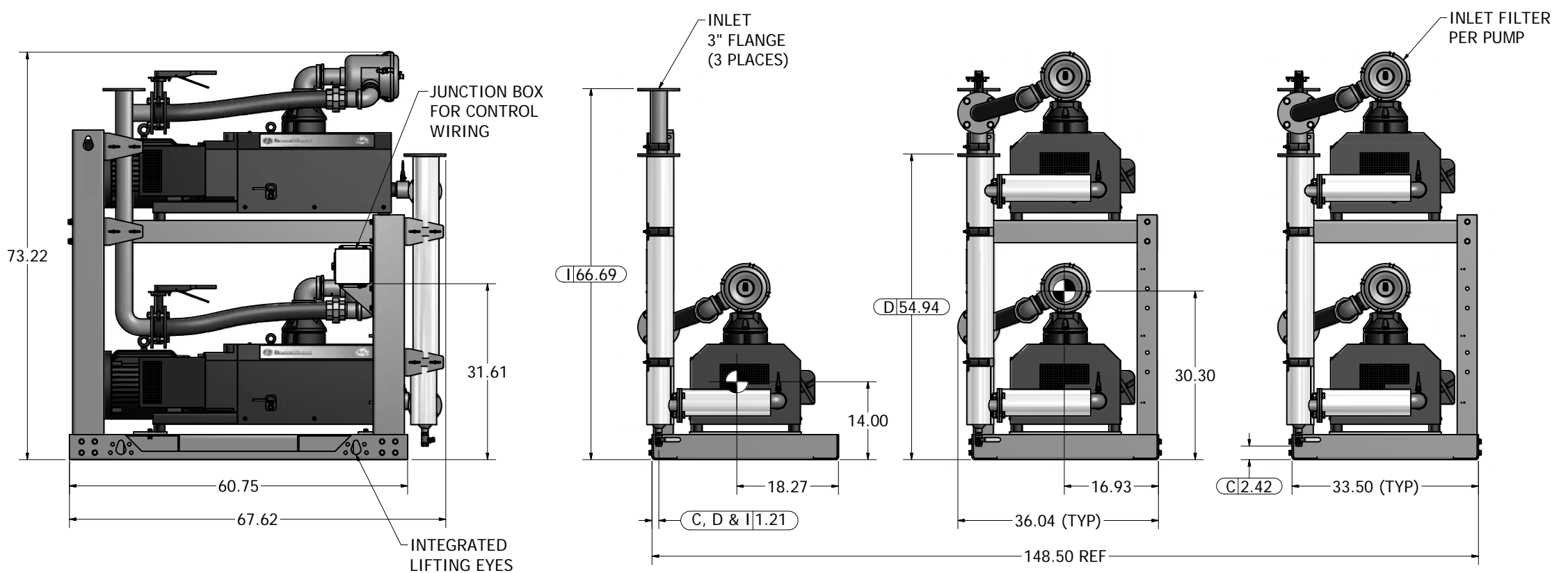
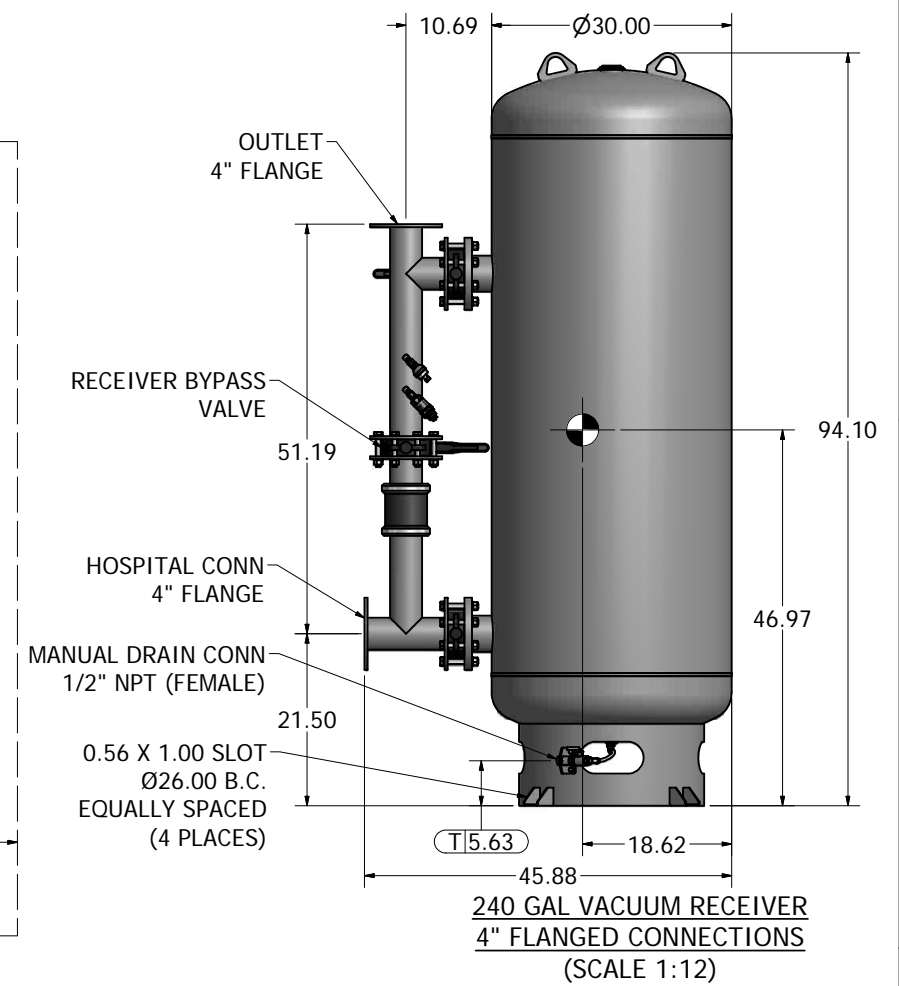
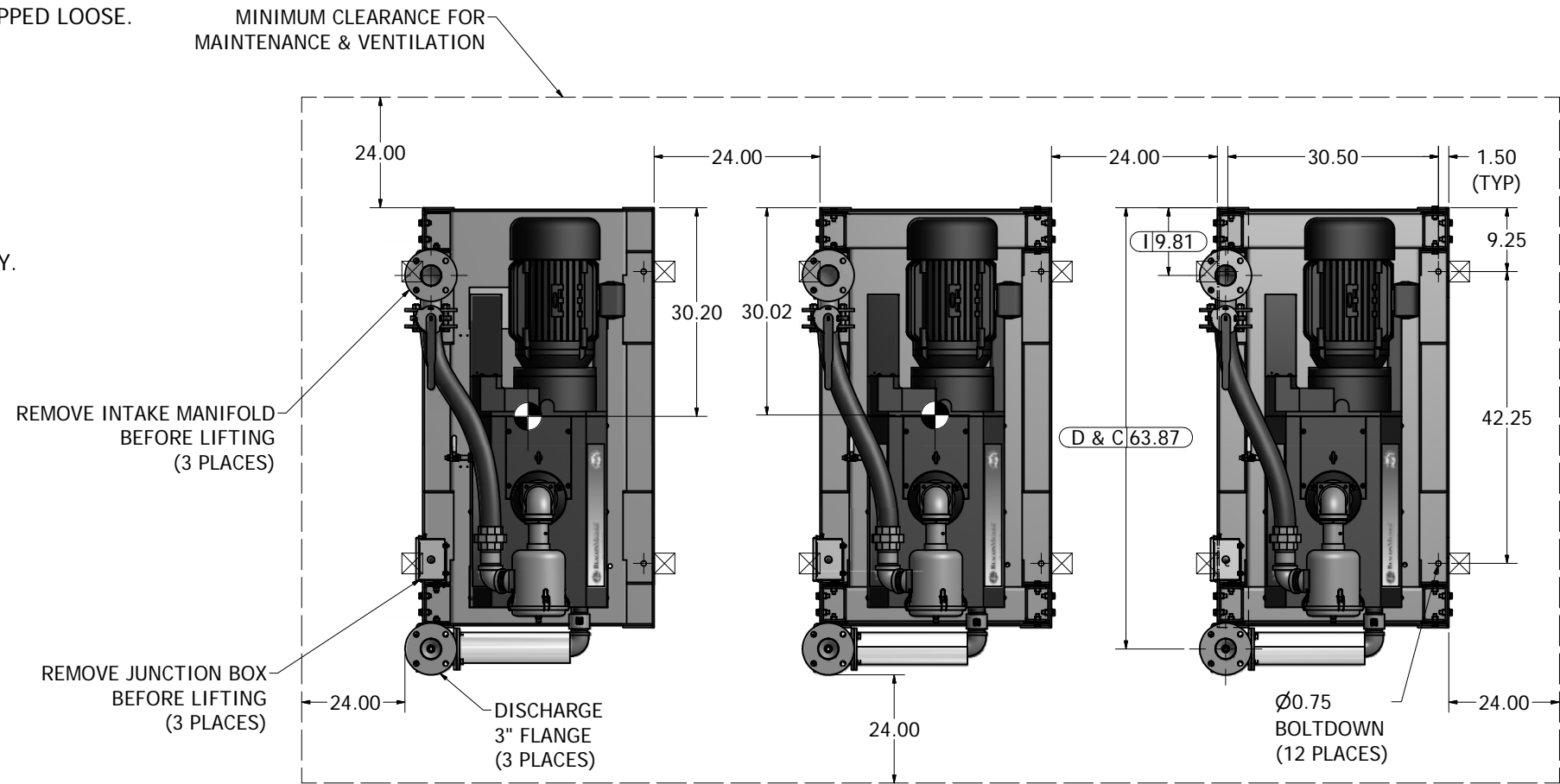

Revised:	Date:	Drawn:	Date:
		JWO	02/07/2014
		This drawing and the information contained therein remain the property of BeaconMedes and may not be used for other than the purpose for which it is loaned without the expressed written permission from BeaconMedes Engineering.	
Description: GENERAL ASSEMBLY 15HP PX CLAW VSD VAC MOD 240G RECEIVER STANDARD		Part Number: 4107 8549 29 DN: HOP131370 Rev: 00 Sheet 1 of 1	
		D	