

NOTES:
 1. DISCHARGE MUFFLERS WILL BE SHIPPED LOOSE.

2. DX MODULE WEIGHT: 2,291 LBS.
 SX MODULE WEIGHT: 1,219 LBS.
 200G TANK WEIGHT: 658 LBS
 CONTROL PANEL WEIGHT: 257 LBS.

3. ☒ INDICATES LIFTING POINT.

4. ● DENOTES CENTER OF GRAVITY.

SYSTEM CONNECTIONS	
ID	DESCRIPTION
I	INLET LOCATION
D	DISCHARGE LOCATION
C	CONDENSATE DRAIN LOCATION
T	TANK DRAIN LOCATION

REMOVE INTAKE MANIFOLD BEFORE LIFTING (3 PLACES)

REMOVE JUNCTION BOX BEFORE LIFTING (3 PLACES)

MINIMUM CLEARANCE FOR MAINTENANCE & VENTILATION

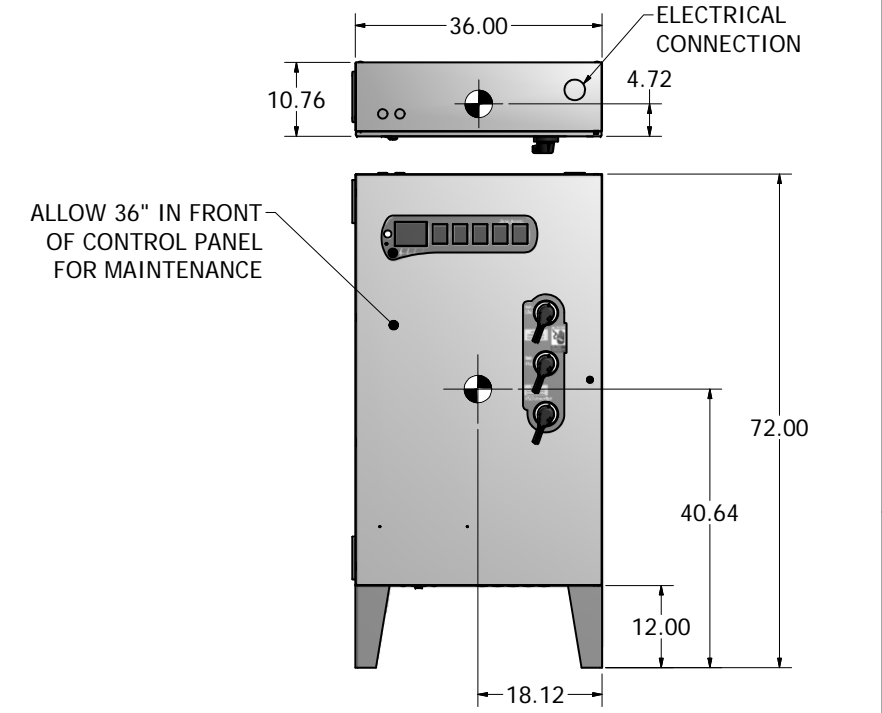
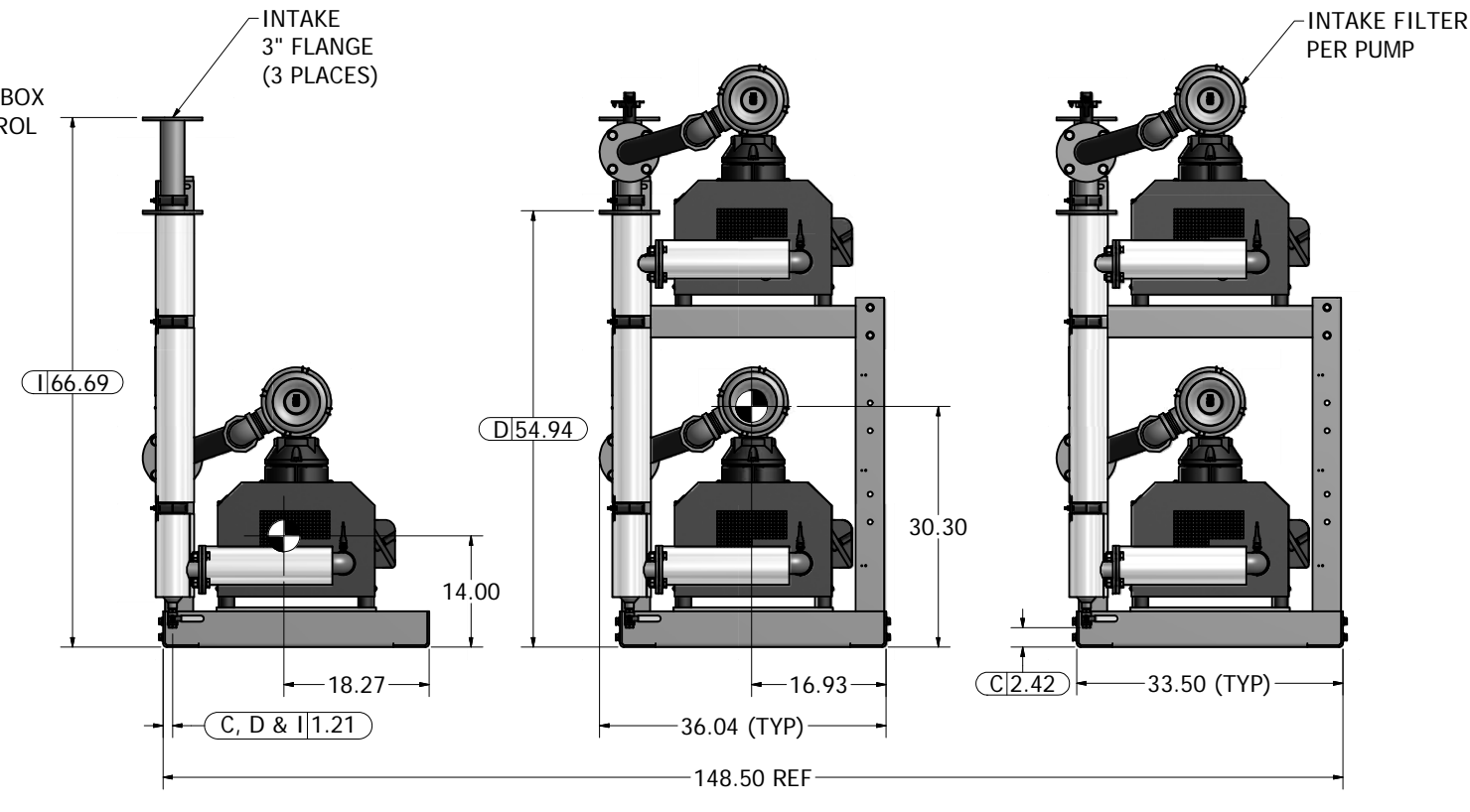
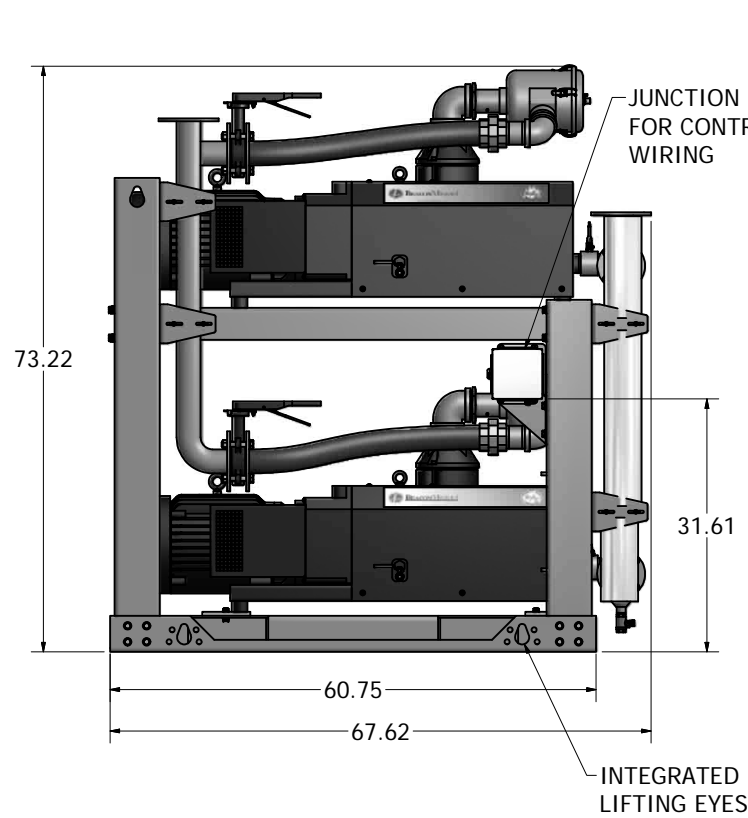
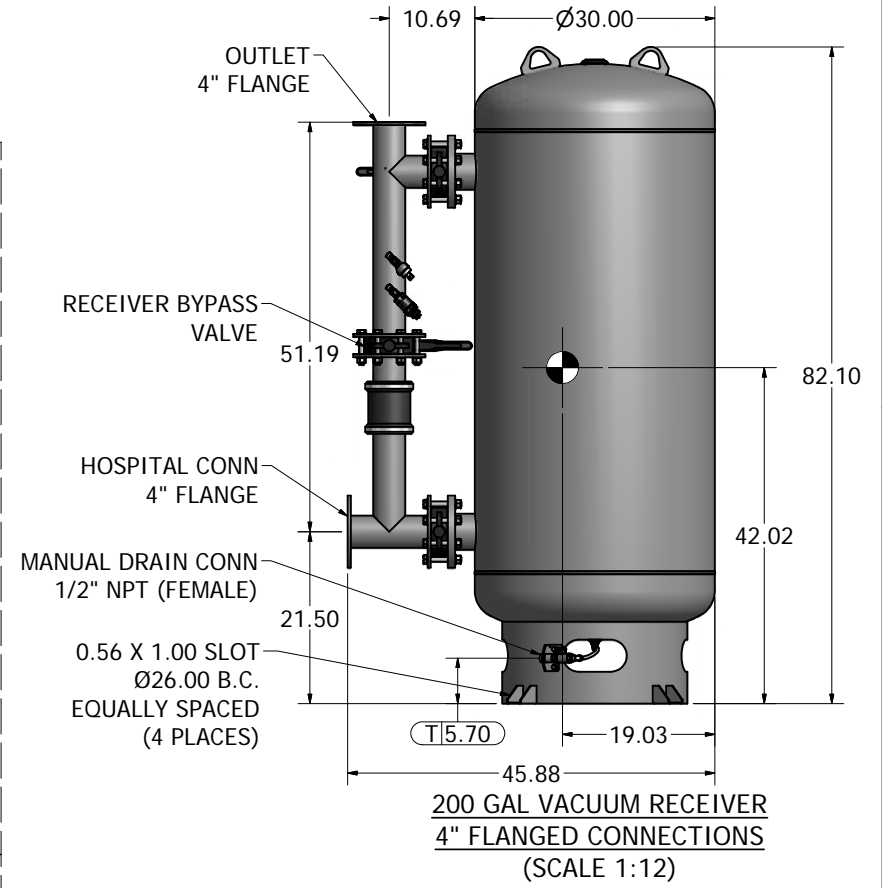
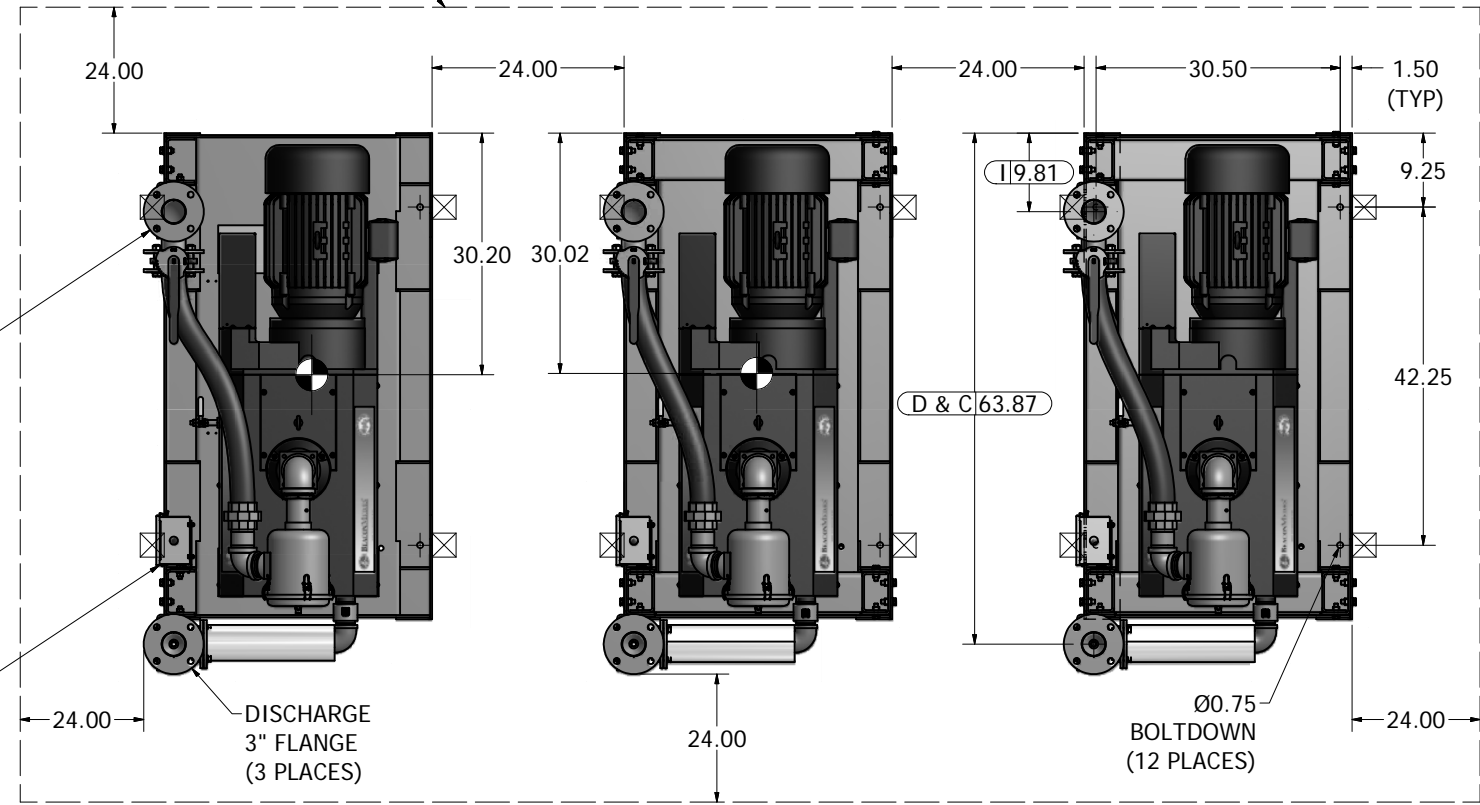

CONTROL PANEL	
Revised:	Date: 02/07/2014
Drawn: JWJ	Scale: 1:12
<p>This drawing and the information contained therein remain the property of BeaconMedes and may not be used for other than the purpose for which it is loaned without the expressed written permission from BeaconMedes Engineering.</p>	
Description:	Part Number: 4107 8549 28
GENERAL ASSEMBLY 15HP PX CLAW VSD VAC MOD 200G RECEIVER STANDARD	Rev: 00
DN: HOP131370	Sheet 1 of 1
DO NOT SCALE THIS DOCUMENT	