

Notes:

- DISCHARGE MUFFLERS WILL BE SHIPPED LOOSE.
- WEIGHT OF DUPLEX MODULE W/ PANEL: 2,393 LBS
WEIGHT OF SIMPLEX MODULE W/O PANEL: 1,219 LBS
240G TANK WEIGHT: 733 LBS
- ☒ INDICATES LIFTING POINT.
- DENOTES CENTER OF GRAVITY.

| SYSTEM CONNECTIONS | |
|--------------------|---------------------------|
| ID | DESCRIPTION |
| I | INLET LOCATION |
| D | DISCHARGE LOCATION |
| C | CONDENSATE DRAIN LOCATION |
| T | TANK DRAIN LOCATION |

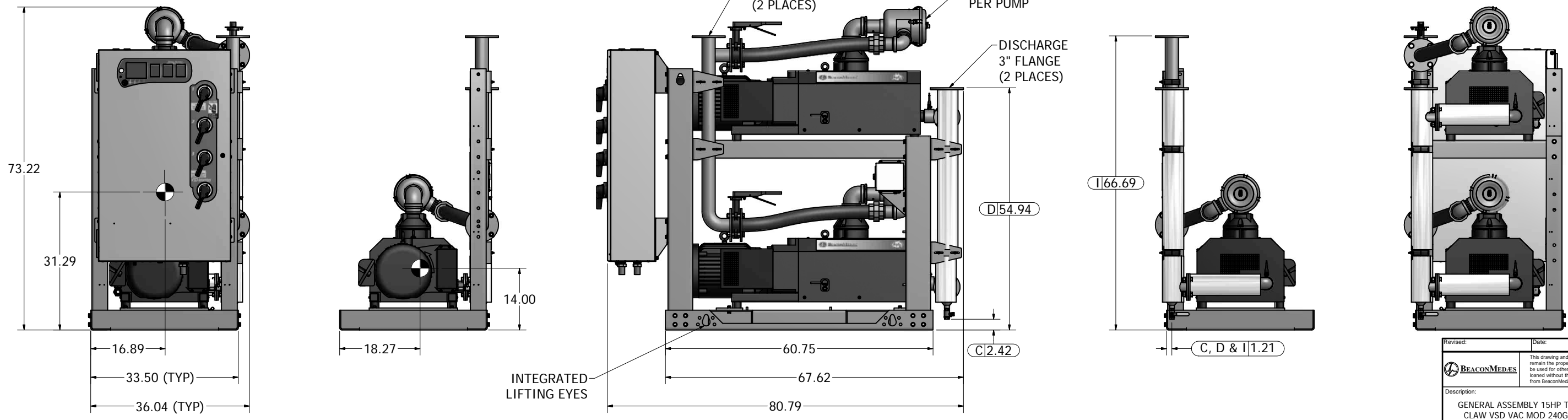
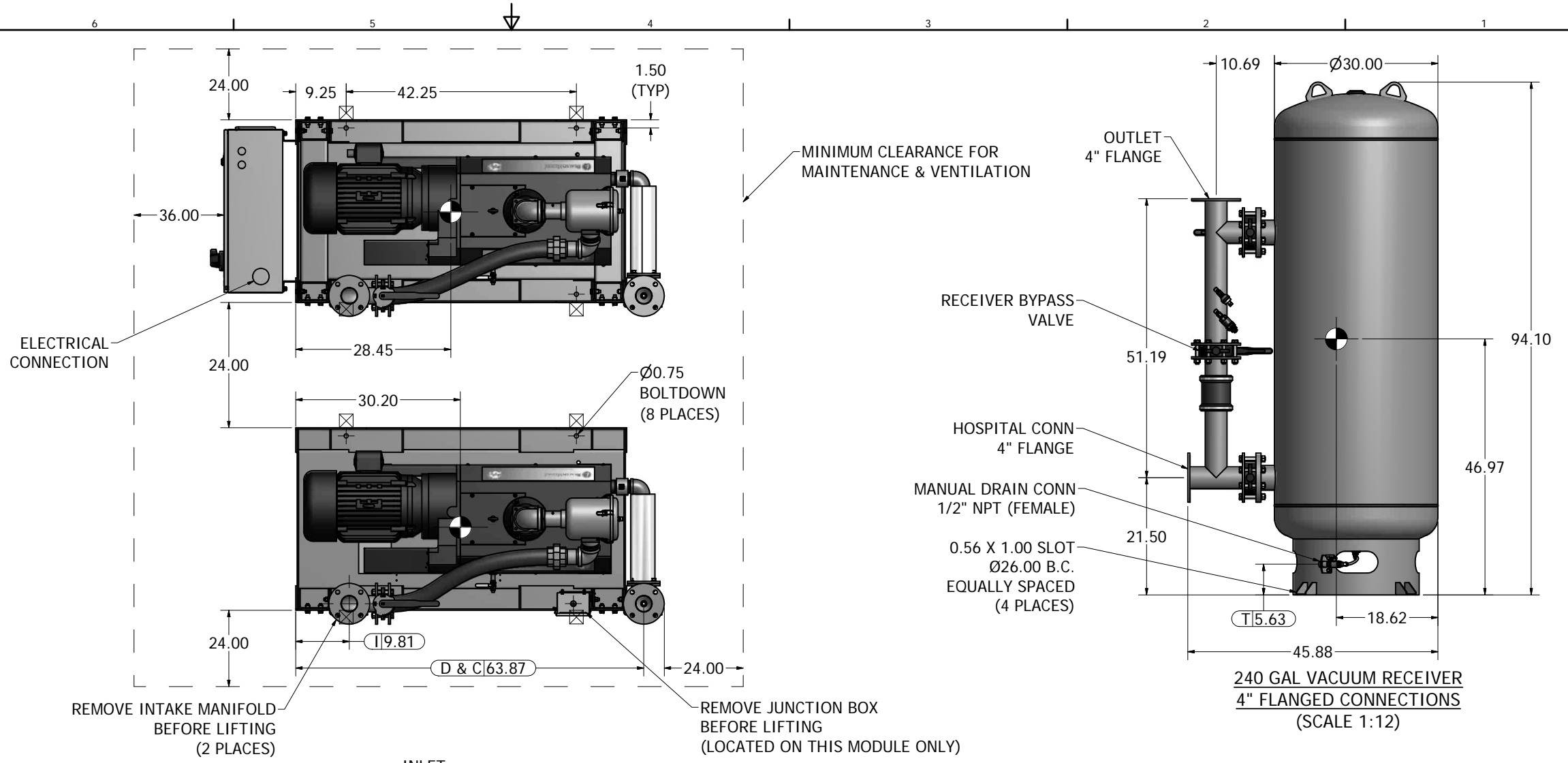

| | | | |
|--|-------|--|------------|
| Revised: | Date: | Drawn: | Date: |
| | | JWO | 02/07/2014 |
| | | This drawing and the information contained therein remain the property of BeaconMedes and may not be used for other than the purpose for which it is loaned without the expressed written permission from BeaconMedes Engineering. | |
| Description: GENERAL ASSEMBLY 15HP TX CLAW VSD VAC MOD 240G RECEIVER STANDARD | | Part Number: 4107 8549 25 DN: HOP131370 Rev: 00 Sheet 1 of 1 DO NOT SCALE THIS DOCUMENT | |