

Notes:

- DISCHARGE MUFFLER WILL BE SHIPPED LOOSE.
- DX MODULE WEIGHT: 2,427 LBS
240G TANK WEIGHT: 713 LBS
- ☒ INDICATES LIFTING POINT.
- DENOTES CENTER OF GRAVITY.

ID	DESCRIPTION
I	INLET LOCATION
D	DISCHARGE LOCATION
C	CONDENSATE DRAIN LOCATION
T	TANK DRAIN LOCATION

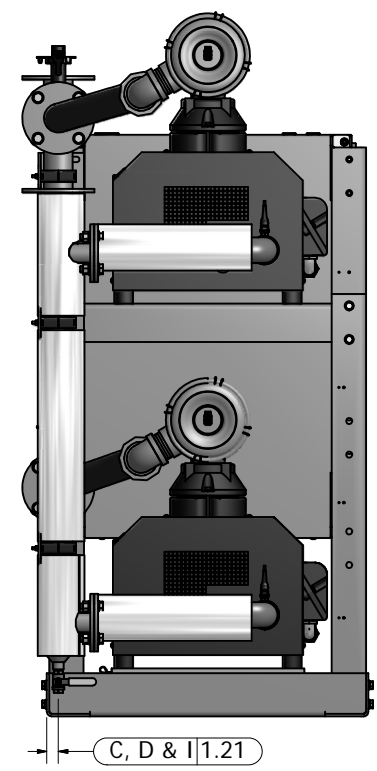
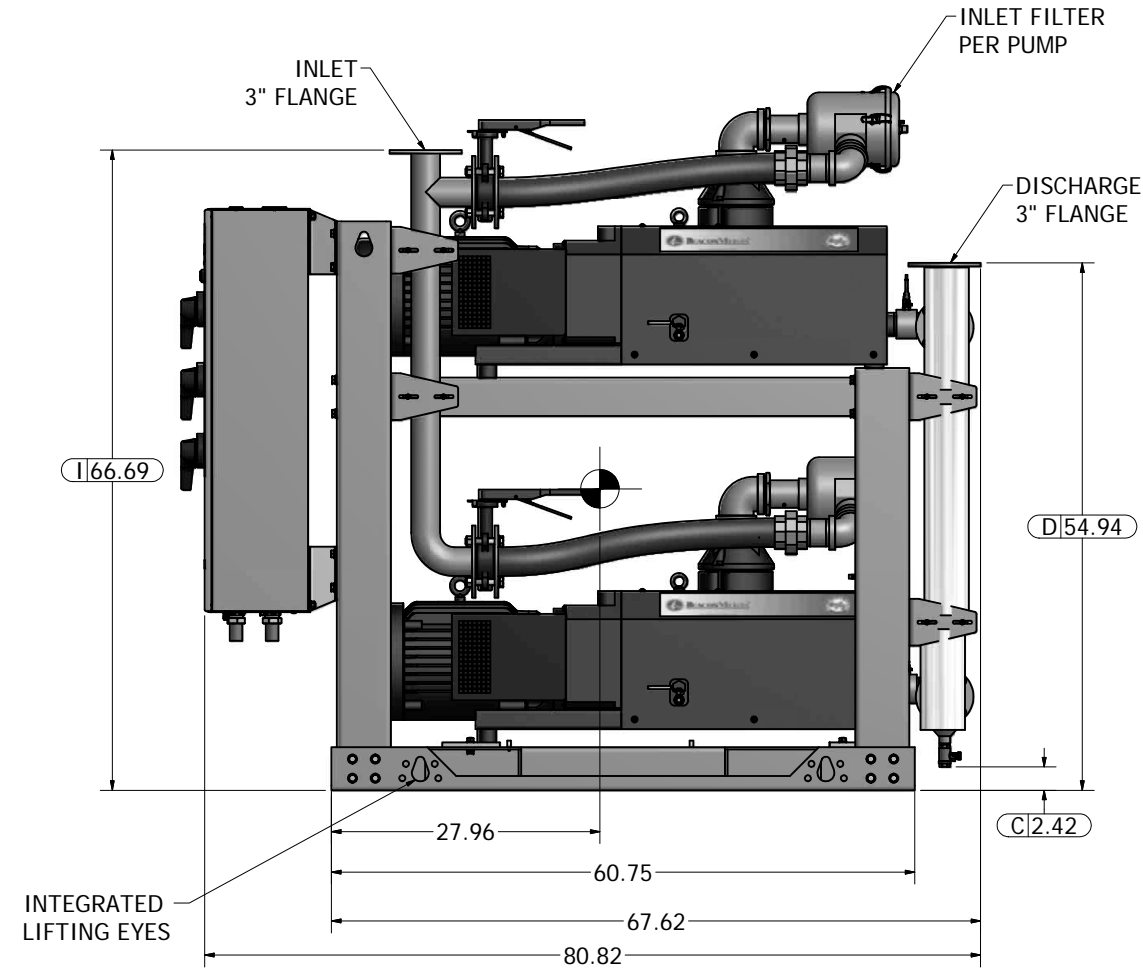
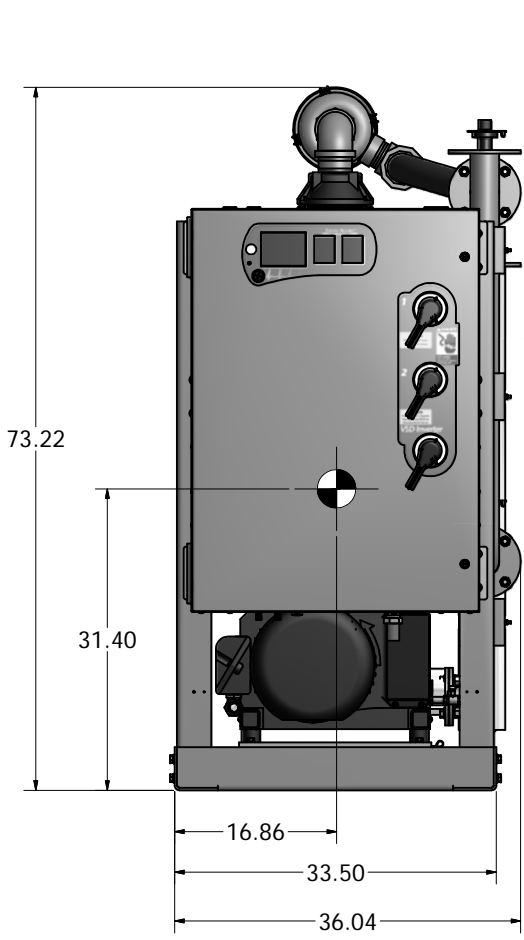
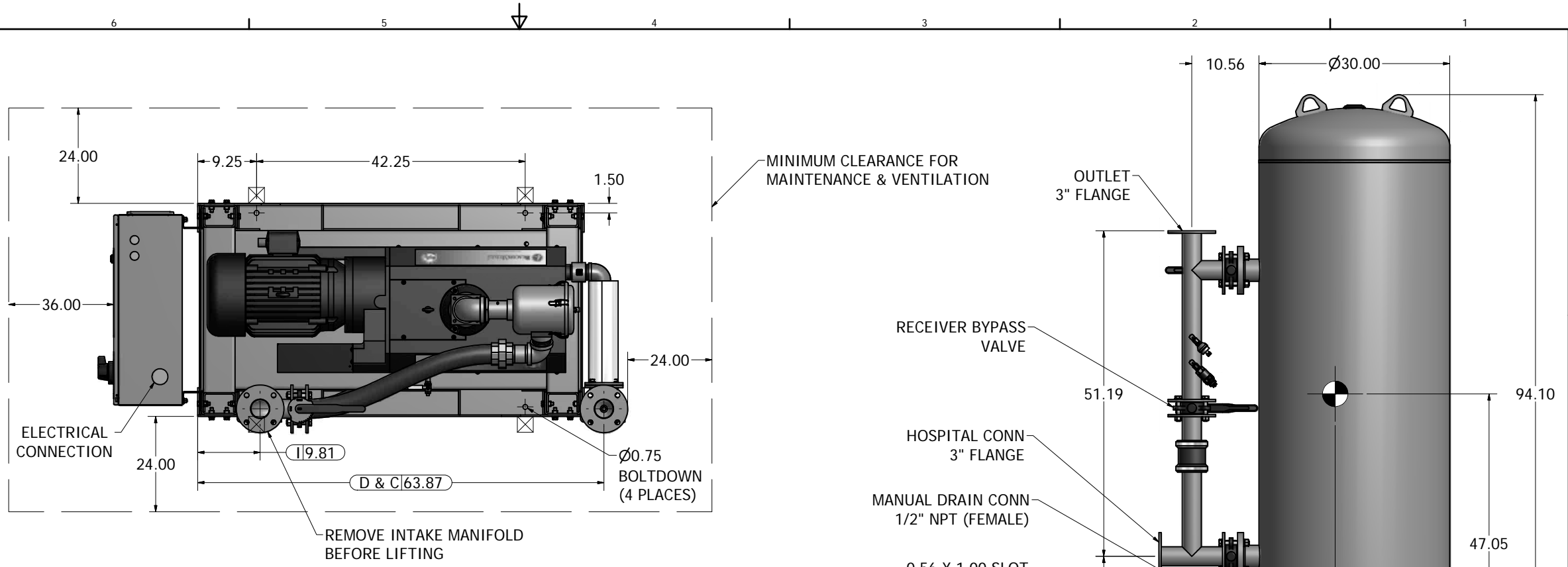

240 GAL VACUUM RECEIVER
3" FLANGED CONNECTIONS
(SCALE 1:10)

Revised:	Date:	Drawn: JWO	Date: 01/29/2014
		This drawing and the information contained therein remain the property of BeaconMedes and may not be used for other than the purpose for which it is loaned without the expressed written permission from BeaconMedes Engineering.	
Description: GENERAL ASSEMBLY 15HP DX CLAW VSD VAC MOD 240G RECEIVER STANDARD		Part Number: 4107 8549 23	Scale: 1:10
DN: HOP131370		Rev: 00	Sheet 1 of 1
DO NOT SCALE THIS DOCUMENT		DO NOT SCALE THIS DOCUMENT	