

Notes:

- DISCHARGE MUFFLERS WILL BE SHIPPED LOOSE.
- WEIGHT OF DUPLEX MODULE W/ PANEL: 2,332 LBS  
WEIGHT OF DUPLEX MODULE W/O PANEL: 2,139 LBS  
200G TANK WEIGHT: 658 LBS
- ☒ INDICATES LIFTING POINT.
- DENOTES CENTER OF GRAVITY.

| SYSTEM CONNECTIONS |                           |
|--------------------|---------------------------|
| ID                 | DESCRIPTION               |
| I                  | INLET LOCATION            |
| D                  | DISCHARGE LOCATION        |
| C                  | CONDENSATE DRAIN LOCATION |
| T                  | TANK DRAIN LOCATION       |

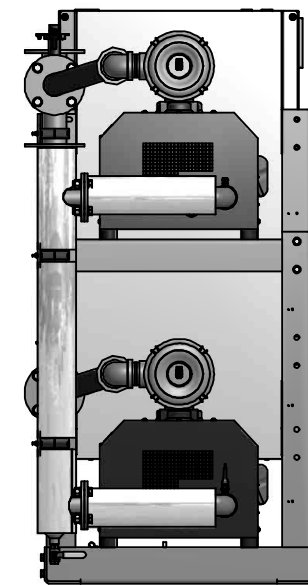
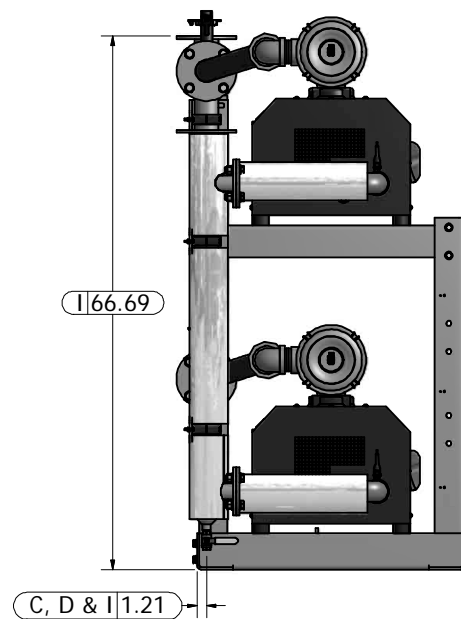
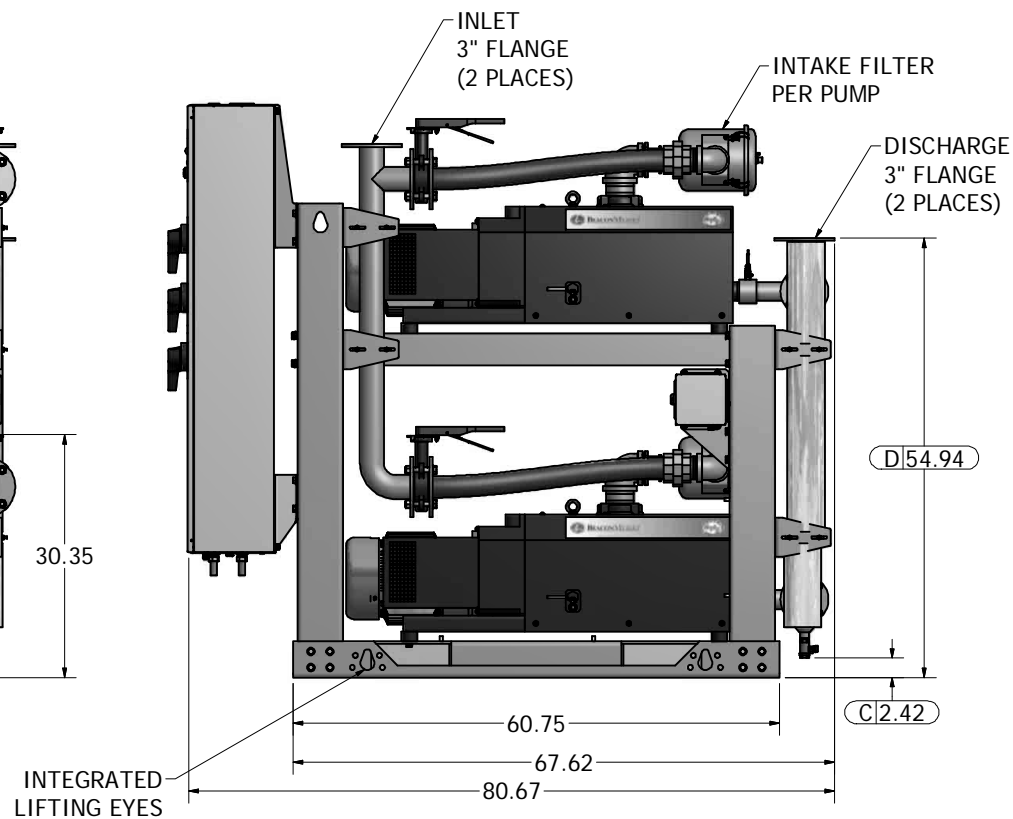
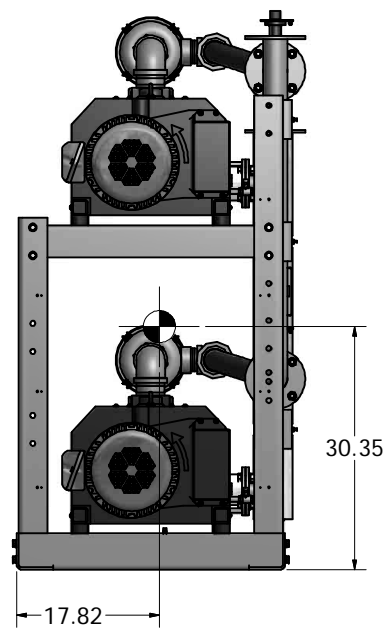
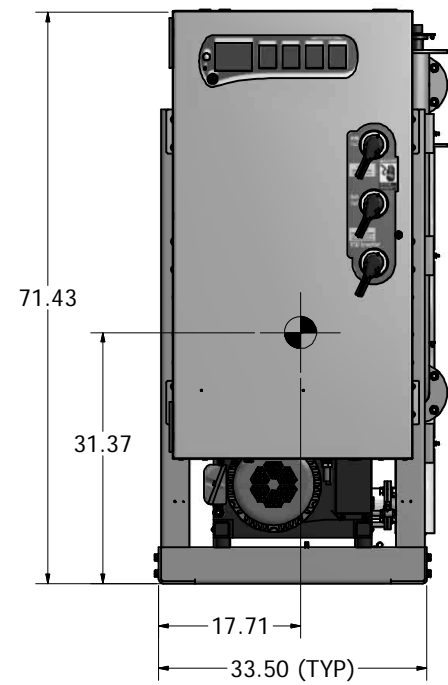
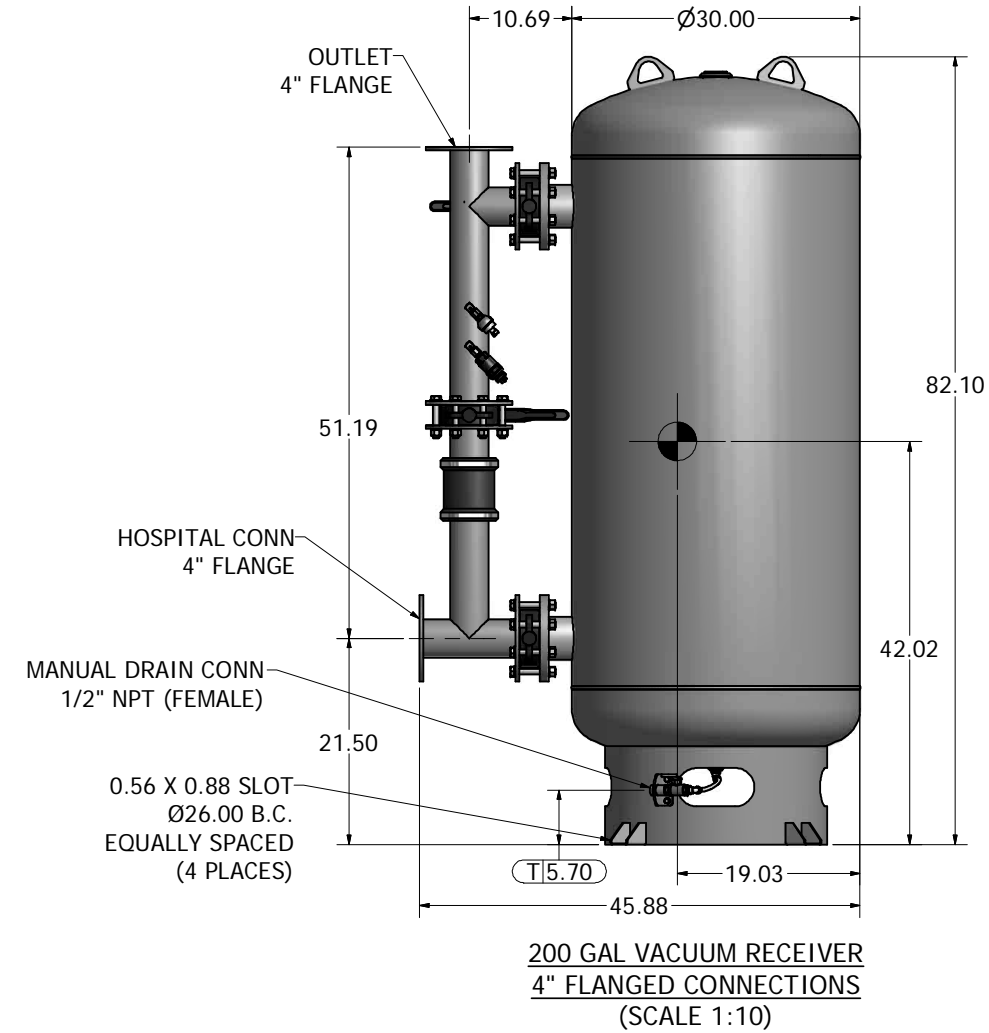
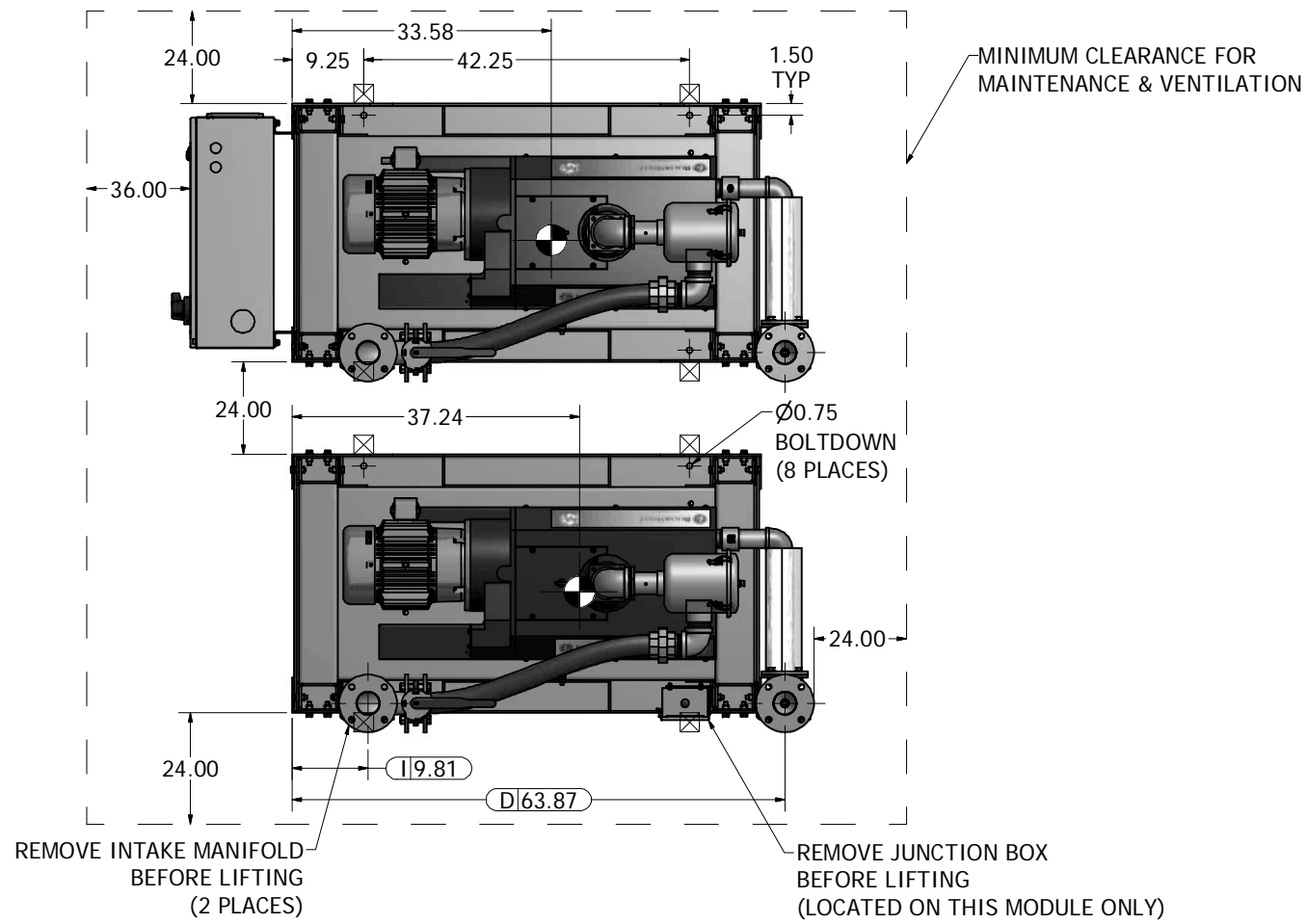

|  |       |  |                     |
|--|-------|--|---------------------|
| Revised:   | Date: | Drawn:   | Date:               |
|  |       | MDB  | 4/17/2012           |
|  |       | This drawing and the information contained therein remain the property of BeaconMedes and may not be used for other than the purpose for which it is loaned without the expressed written permission from BeaconMedes Engineering. |                     |
| Description:<br>GENERAL ASSEMBLY 10HP OX<br>CLAW VSD VAC MOD 200G<br>RECEIVER STANDARD AND O2<br>ASSURED |       | Part Number:<br>4107 8539 39   | Scale:<br>1/12<br>D |
| DN:<br>HOP120412   |       | Rev:<br>00   | Sheet<br>1 of 1     |
|  |       | DO NOT SCALE THIS DOCUMENT   |                     |