

Notes:

- DISCHARGE MUFFLERS & FLEX HOSES WILL BE SHIPPED LOOSE.
- DX MODULE WEIGHT: 2,275 LBS  
200G TANK WEIGHT: 638 LBS
- ⊠ INDICATES LIFTING POINT.
- DENOTES CENTER OF GRAVITY.

SYSTEM CONNECTIONS	
ID	DESCRIPTION
I	INLET LOCATION
D	DISCHARGE LOCATION
C	CONDENSATE DRAIN LOCATION
T	TANK DRAIN LOCATION

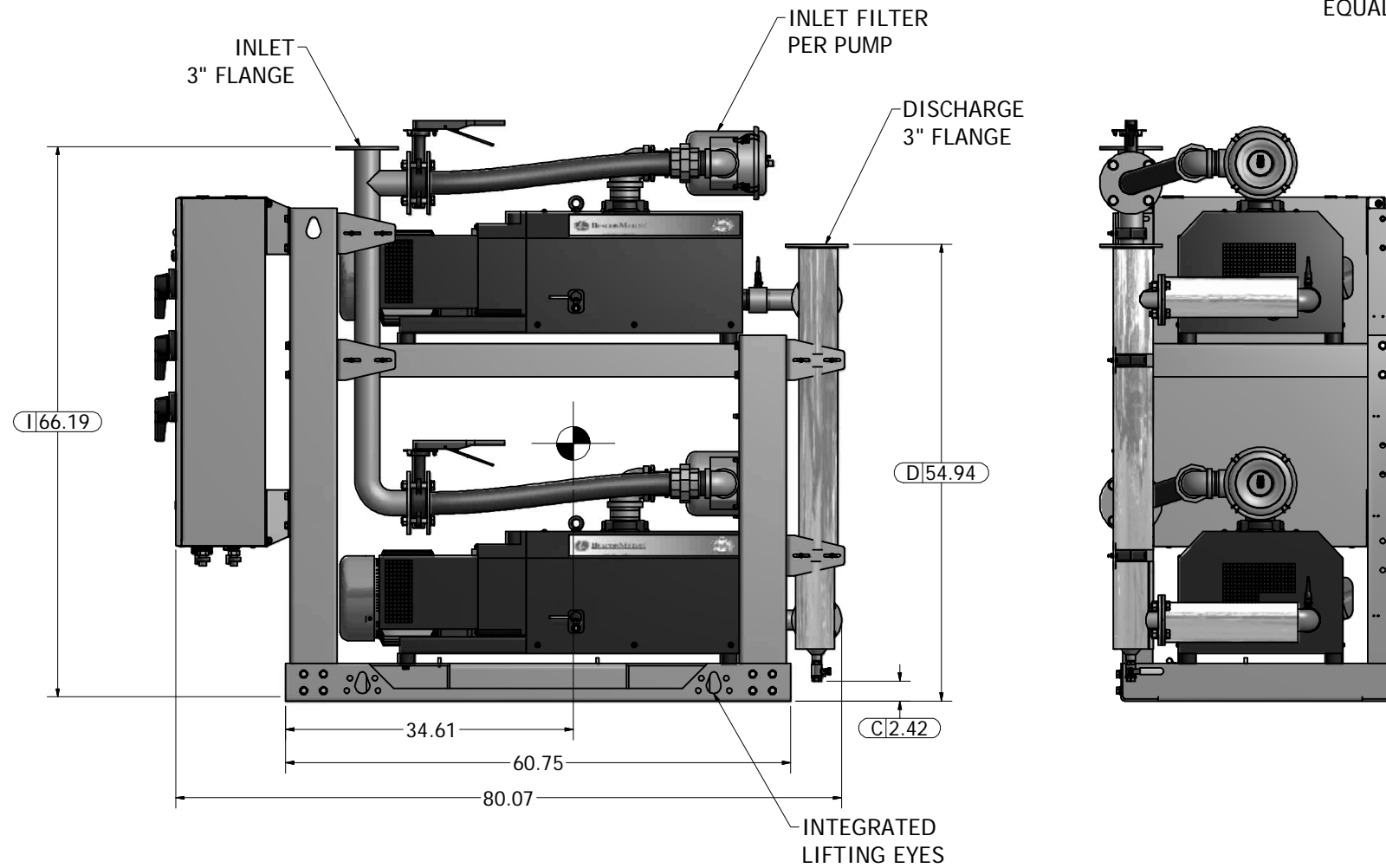
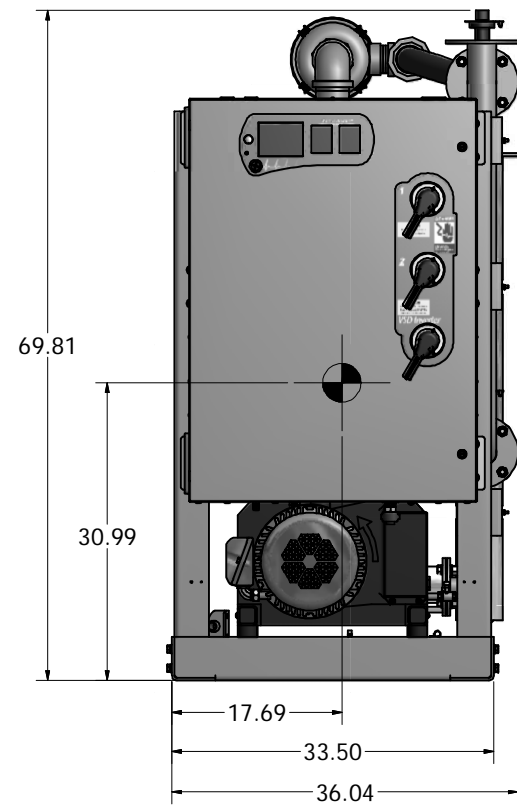
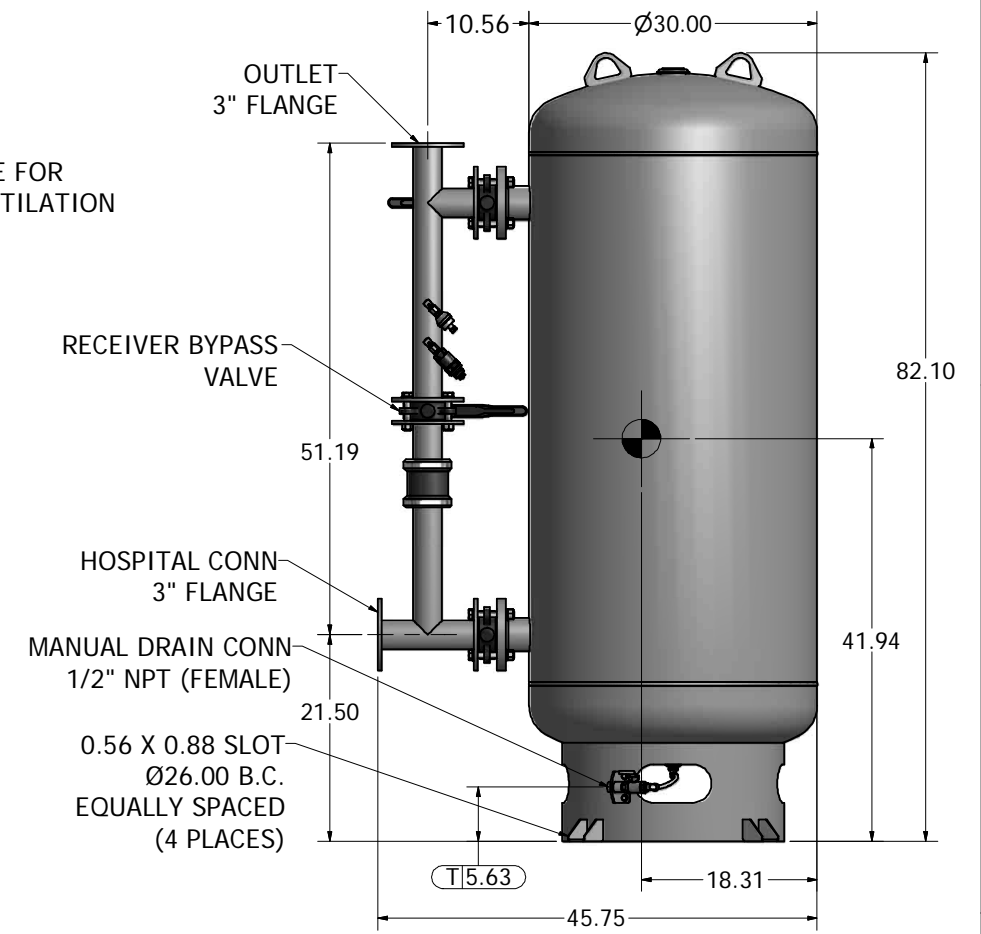
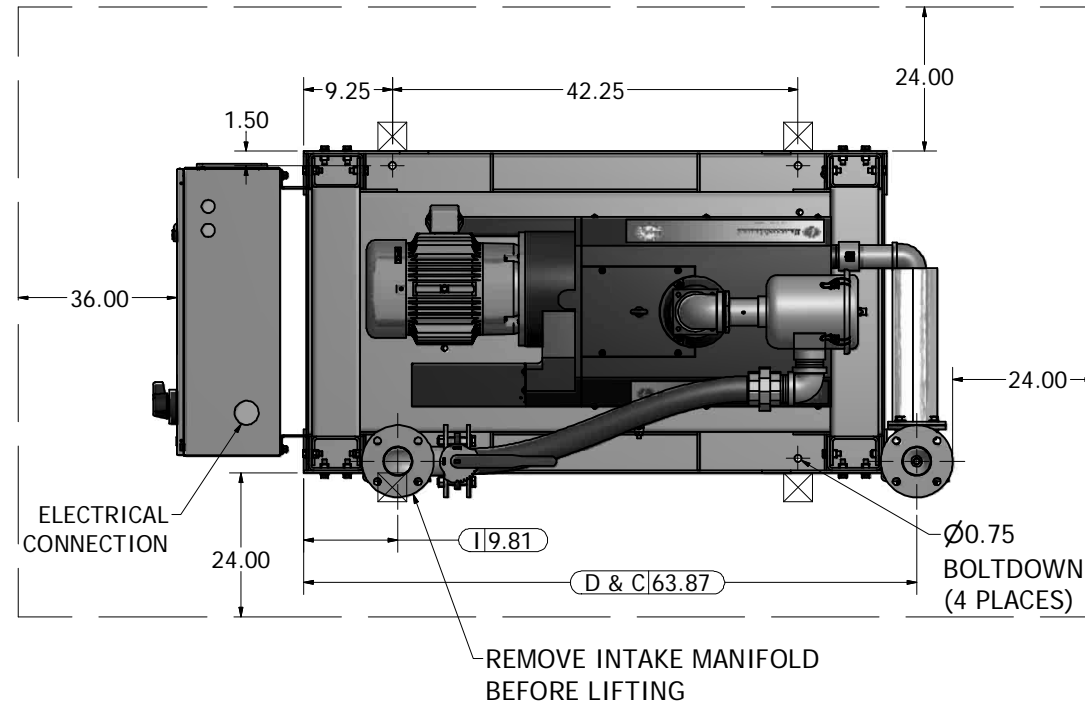

Revised:	Date:	Drawn:	Date:
		MDB	4/17/2012
		This drawing and the information contained therein remain the property of BeaconMedes and may not be used for other than the purpose for which it is loaned without the expressed written permission from BeaconMedes Engineering.	
Description: GENERAL ASSEMBLY 10HP DX CLAW VSD VAC MOD 200G RECEIVER STANDARD AND O2 ASSURED		Part Number: 4107 8539 35	Scale: 1/10 D
DN: HOP120412		Rev: 00	Sheet 1 of 1
		DO NOT SCALE THIS DOCUMENT	