

- Notes:
- DISCHARGE MUFFLER WILL BE SHIPPED LOOSE.
  - TX MODULE WEIGHT: 2,631 LBS  
240G TANK WEIGHT: 713 LBS
  - ☒ INDICATES LIFTING POINT.
  - DENOTES CENTER OF GRAVITY.

SYSTEM CONNECTIONS	
ID	DESCRIPTION
I	INLET LOCATION
D	DISCHARGE LOCATION
C	CONDENSATE DRAIN LOCATION
T	TANK DRAIN LOCATION

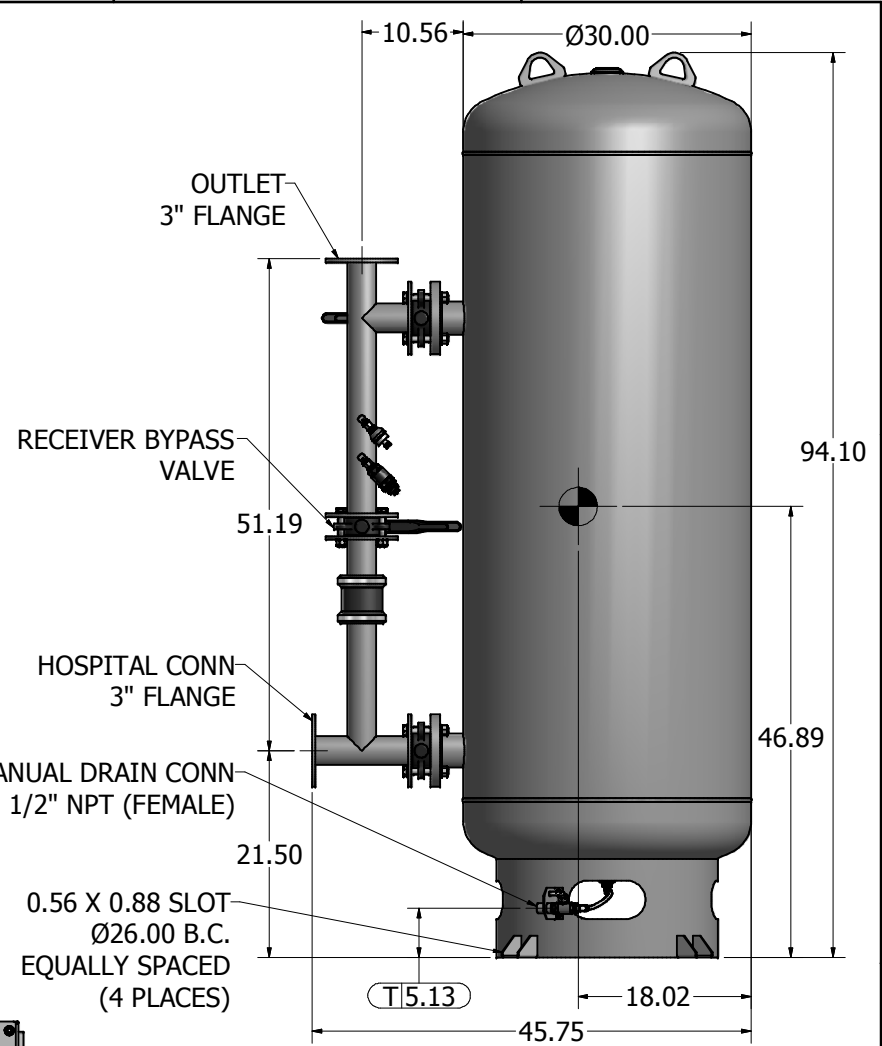
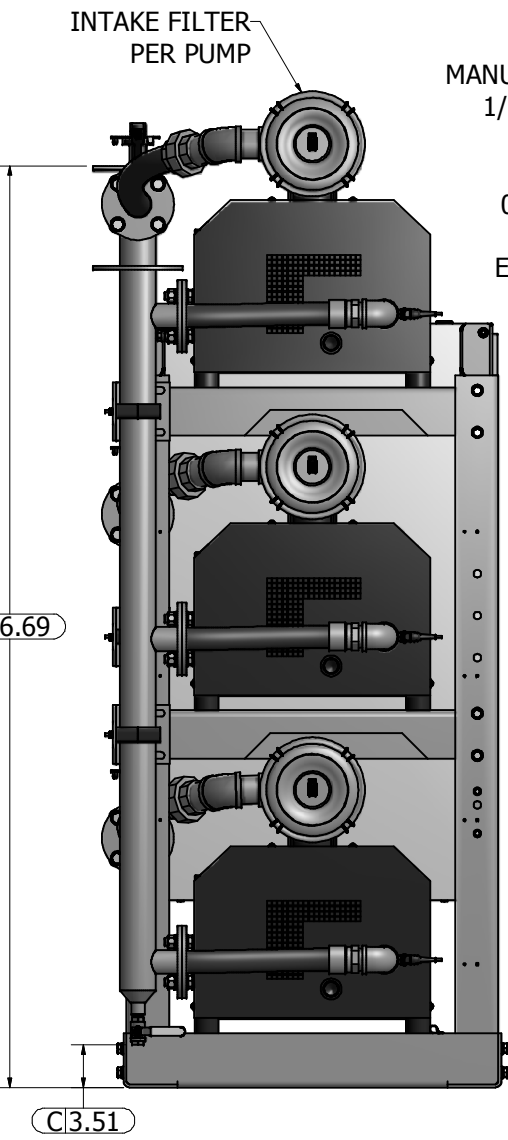
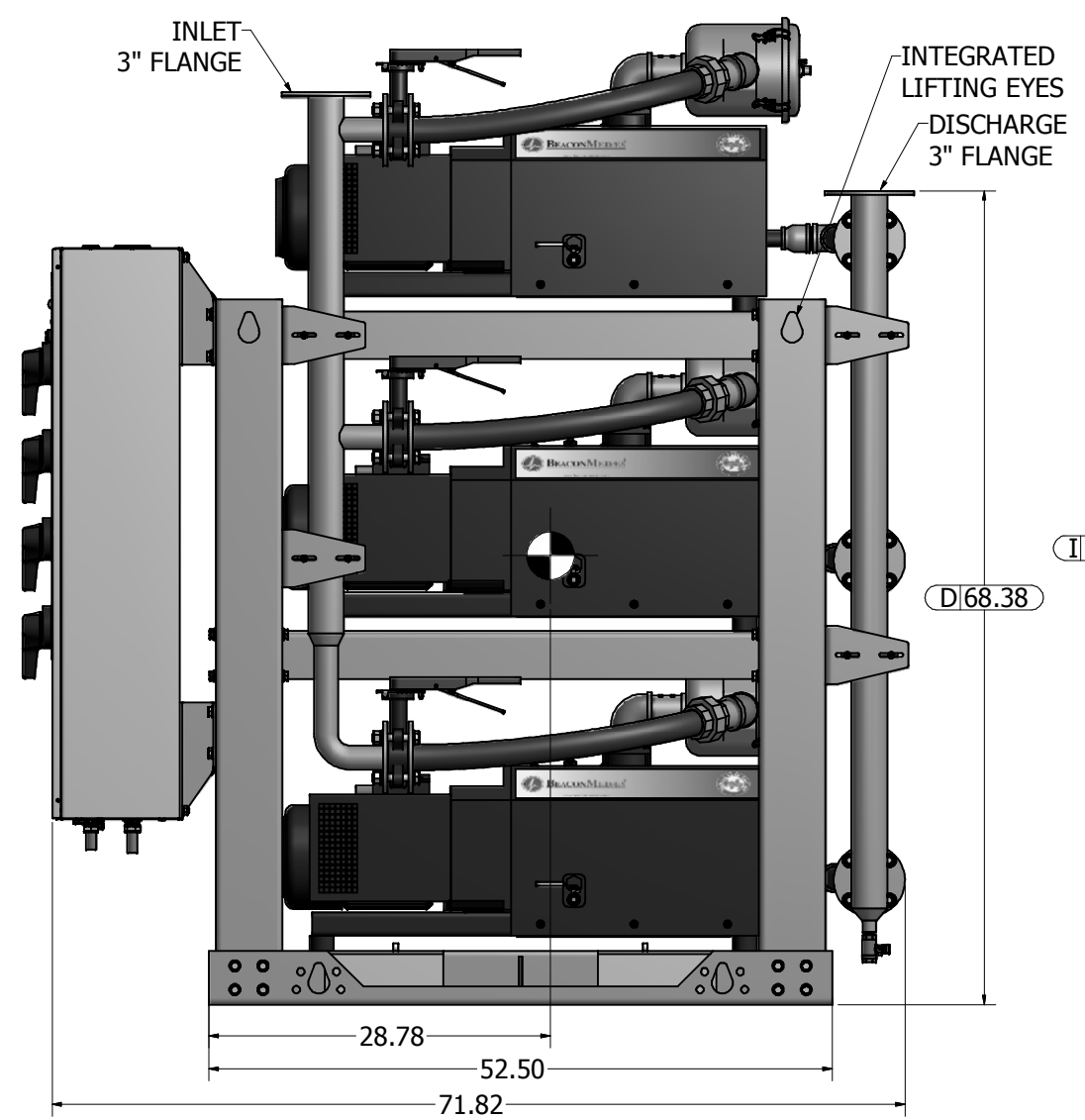
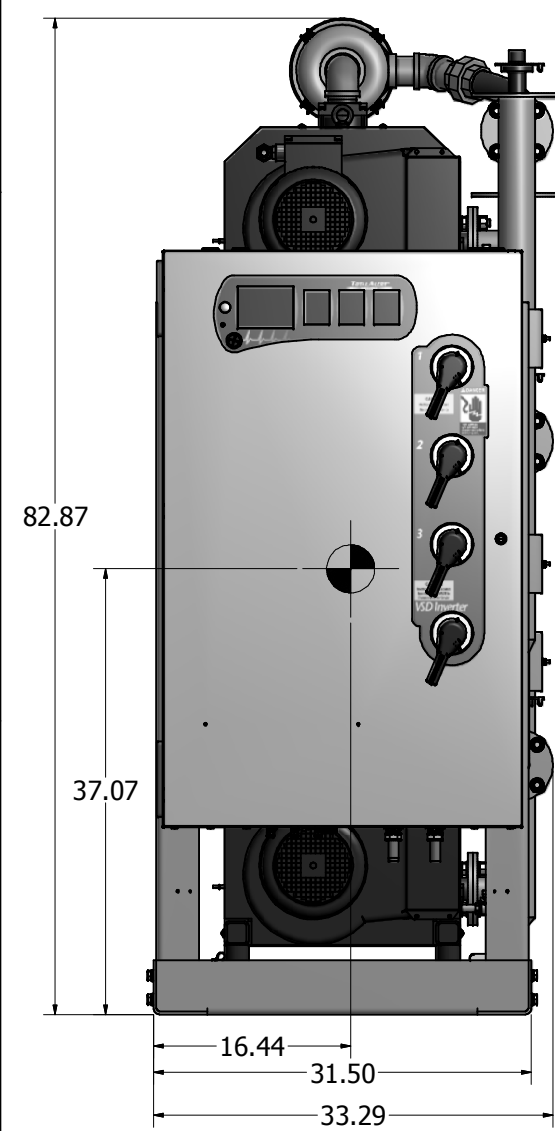
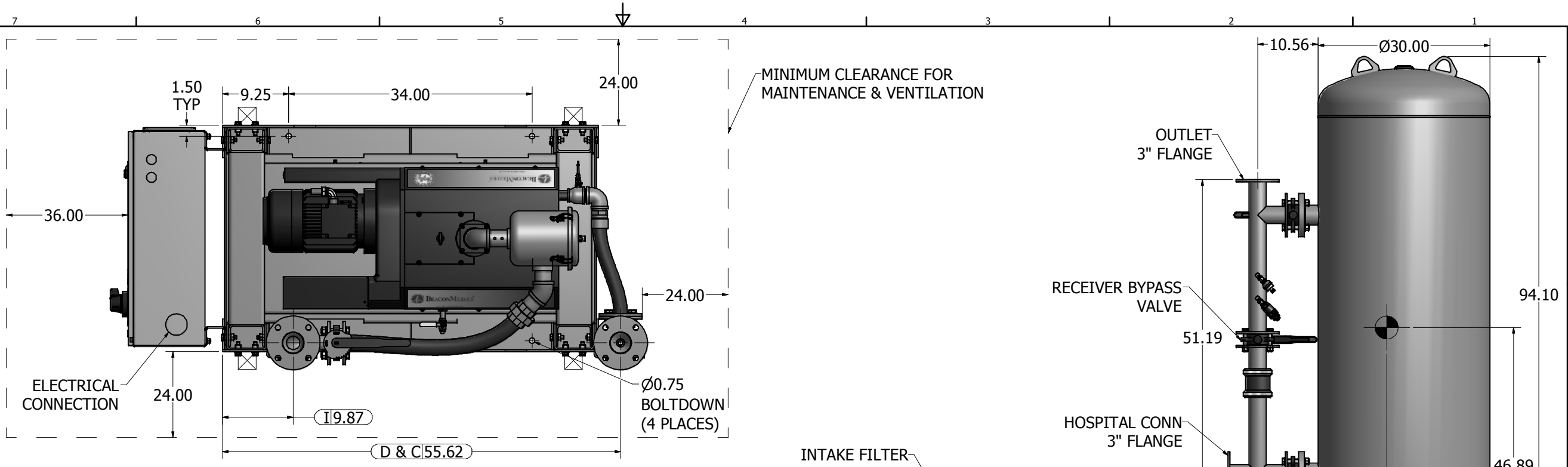

240 GAL VACUUM RECEIVER  
3" FLANGED CONNECTIONS  
(SCALE 1:10)

Revised:	Date:	Drawn: usnbw	Date: 3/30/2010
		This drawing and the information contained thereon remain the property of BeaconMedes and may not be used for other than the purpose for which it is loaned without the expressed written permission from BeaconMedes Engineering.	
Description: GENERAL ASSEMBLY 6.4HP TX CLAW VSD VAC MOD 240G RECEIVER STANDARD AND O2 ASSURED		Part Number: 4107 8514 17	Scale: 1/8 <b>D</b>
DN:	USN100301	Rev:	00
Sheet	1 of 1	DO NOT SCALE THIS DOCUMENT	