

This drawing and the information contained thereon remain the property of BeaconMedes and may not be used for other than the purpose for which it is loaned without the expressed written permission from BeaconMedes Engineering.

- Notes:
- DISCHARGE MUFFLER WILL BE SHIPPED LOOSE.
 - DX MODULE W/PANEL WEIGHT: 1,897 LBS.
DX MODULES WEIGHT: 1,690 LBS. (INCLUDES WEIGHT OF FUTURE EXPANSION PUMP)
240G TANK WEIGHT: 713 LBS
 - ⊠ INDICATES LIFTING POINT.
 - DENOTES CENTER OF GRAVITY. (INCLUDES WEIGHT OF EXPANSION PUMP)

ID	DESCRIPTION
I	INLET LOCATION
D	DISCHARGE LOCATION
C	CONDENSATE DRAIN LOCATION
T	TANK DRAIN

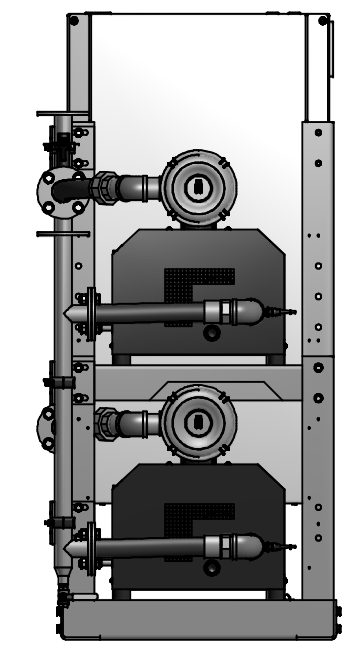
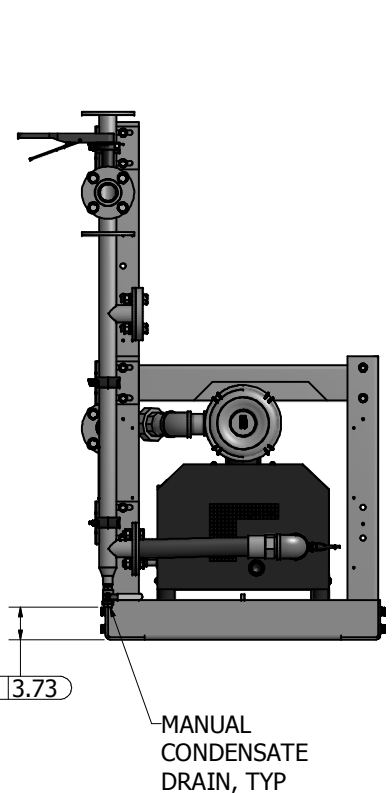
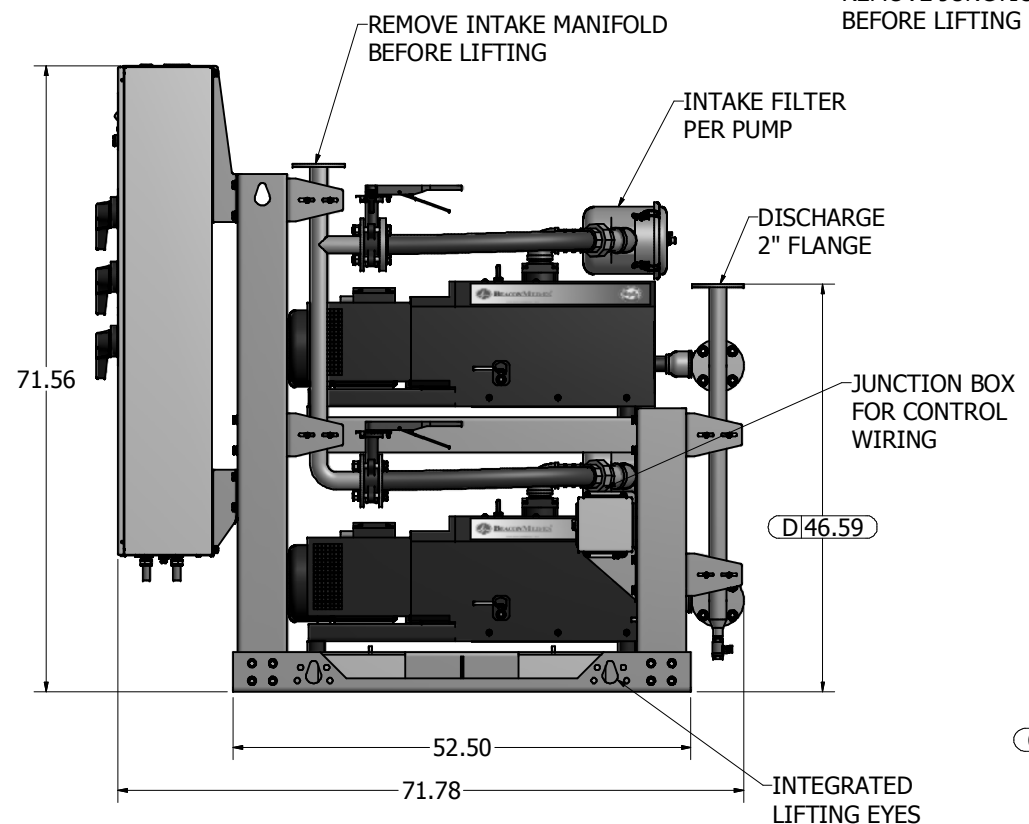
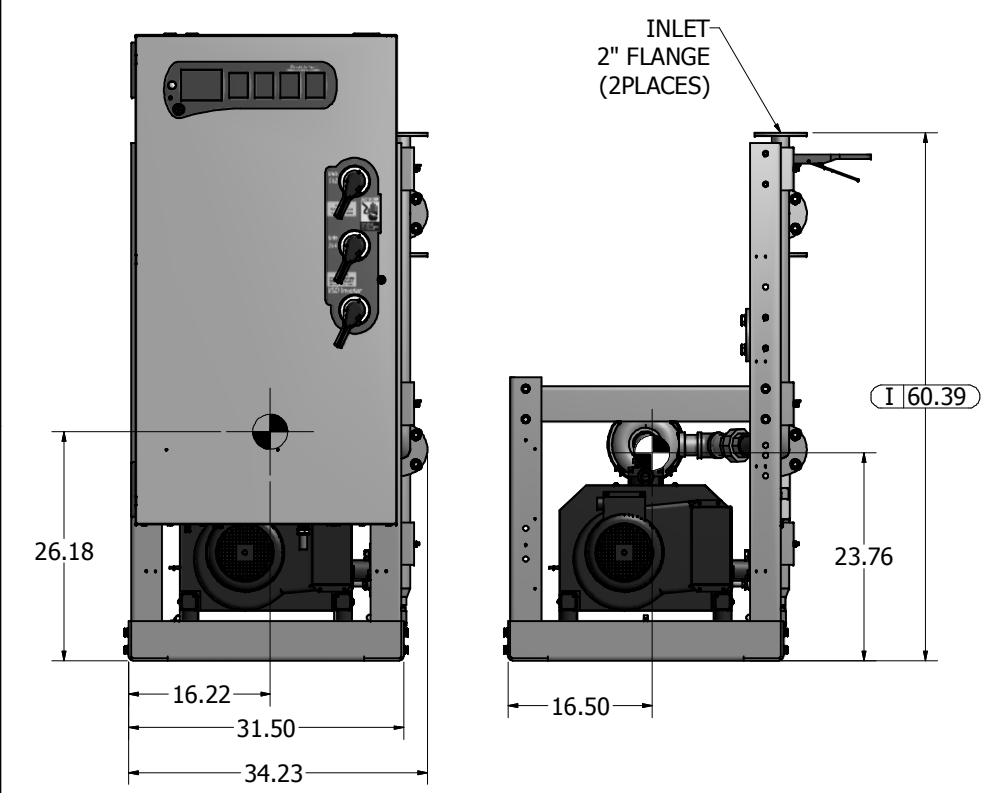
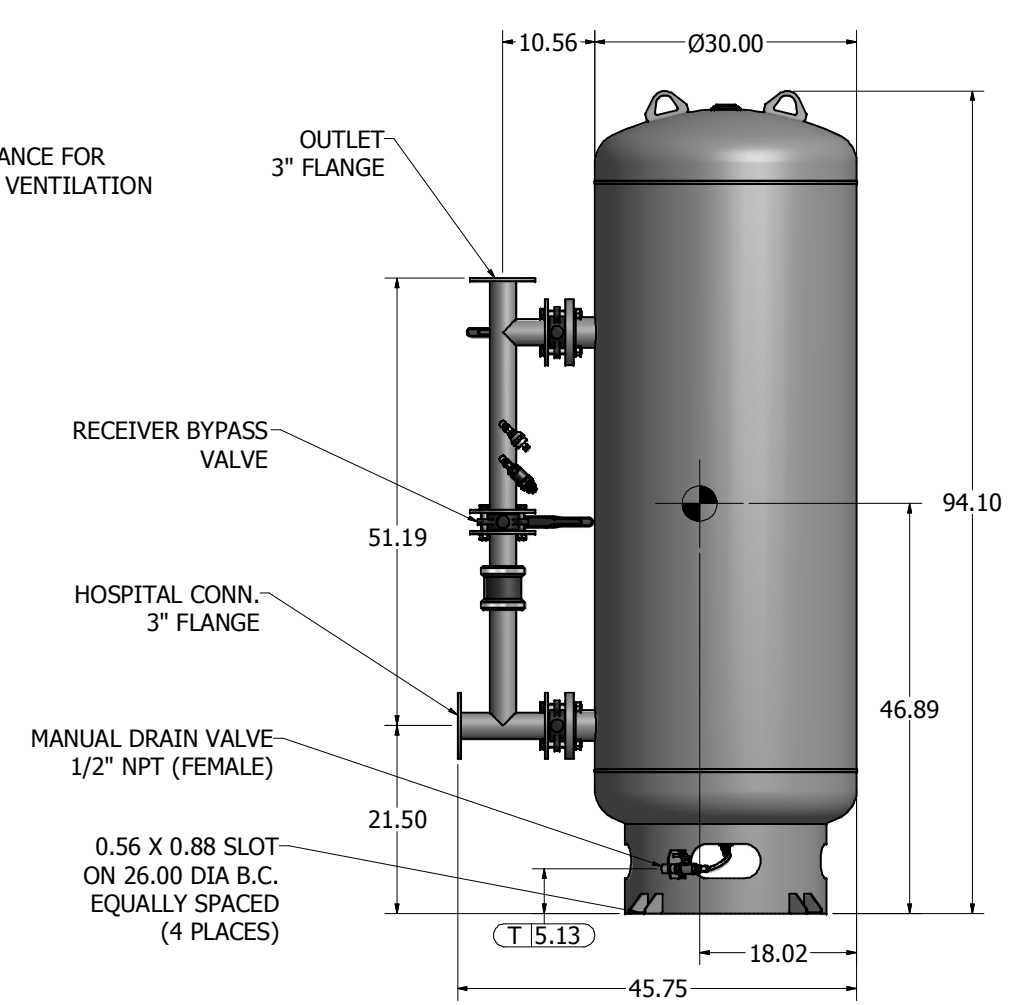
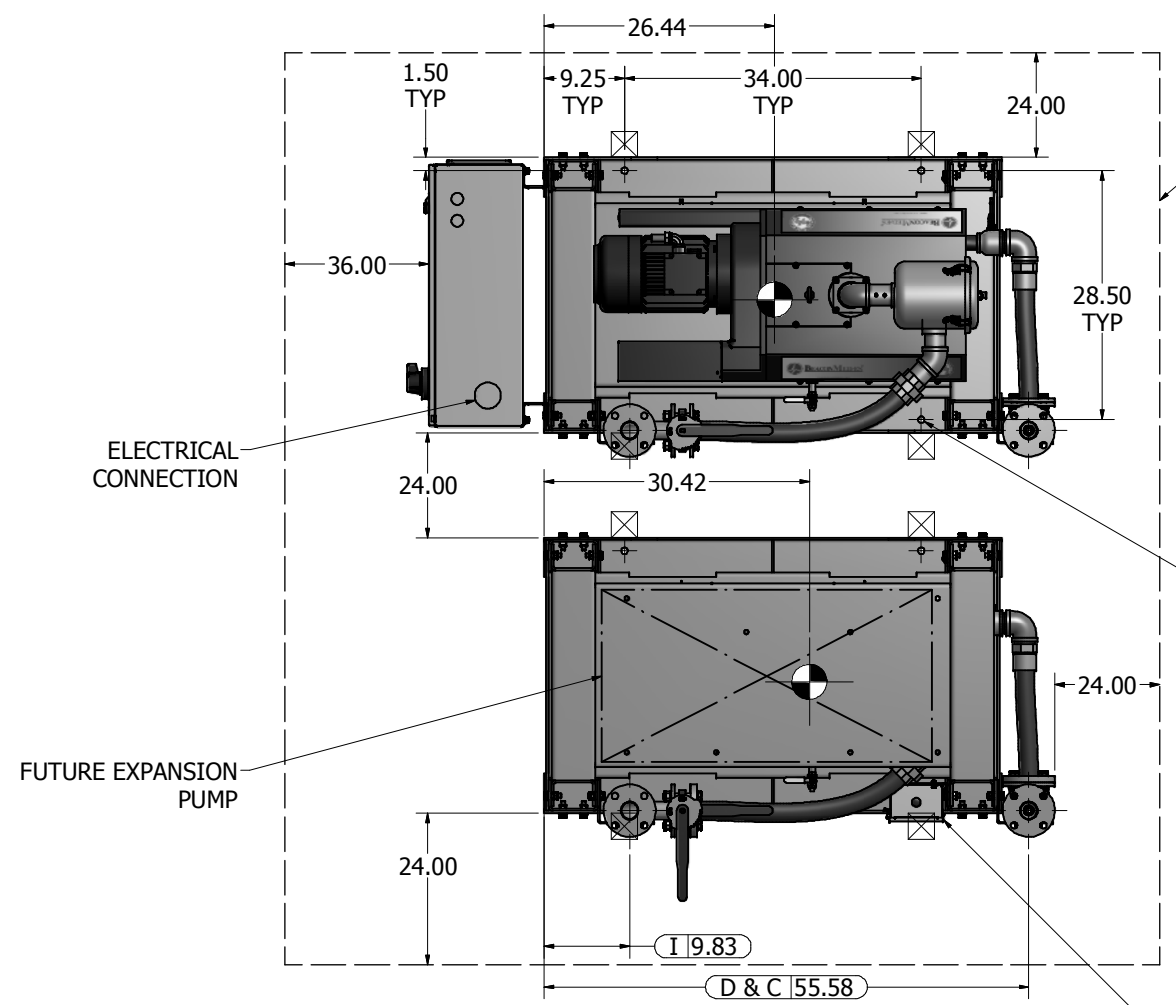

Revised:	Date:	Drawn: BJM	Date: 7/7/2010
UNLESS OTHERWISE SPECIFIED ALL DIMENSIONS ARE IN INCHES AND TOLERANCES ARE: XXX ±.02 XXXX ±.005 ANGLES ±.5°			
Description: GENERAL ASSEMBLY 8.7HP TX-X-QX CLAW VSD VAC MOD 240G RECEIVER STANDARD AND O2 ASSURED		Part Number: 4107 8515 64	Scale: 1:11
DN: USN100358	Rev: 00	Sheet 1 of 1	DO NOT SCALE THIS DOCUMENT