

This drawing and the information contained thereon remain the property of BeaconMedes and may not be used for other than the purpose for which it is loaned without the expressed written permission from BeaconMedes Engineering.

- Notes:
- DISCHARGE MUFFLER WILL BE SHIPPED LOOSE.
 - DX MODULE W/PANEL WEIGHT: 1,877 LBS.
DX MODULE WEIGHT: 1,671 LBS. (INCLUDES WEIGHT OF EXPANSION PUMP)
200G TANK WEIGHT: 638 LBS
 - ☒ INDICATES LIFTING POINT.
 - DENOTES CENTER OF GRAVITY. (INCLUDES FUTURE EXPANSION PUMP)

ID	SYSTEM CONNECTIONS DESCRIPTION
I	INLET LOCATION
D	DISCHARGE LOCATION
C	CONDENSATE DRAIN LOCATION
T	TANK DRAIN

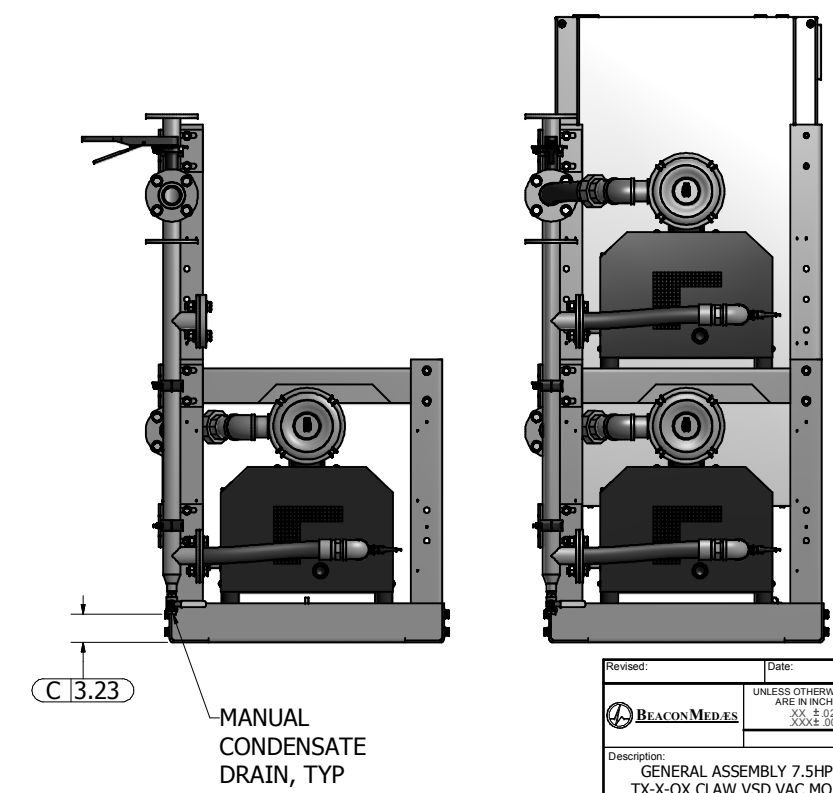
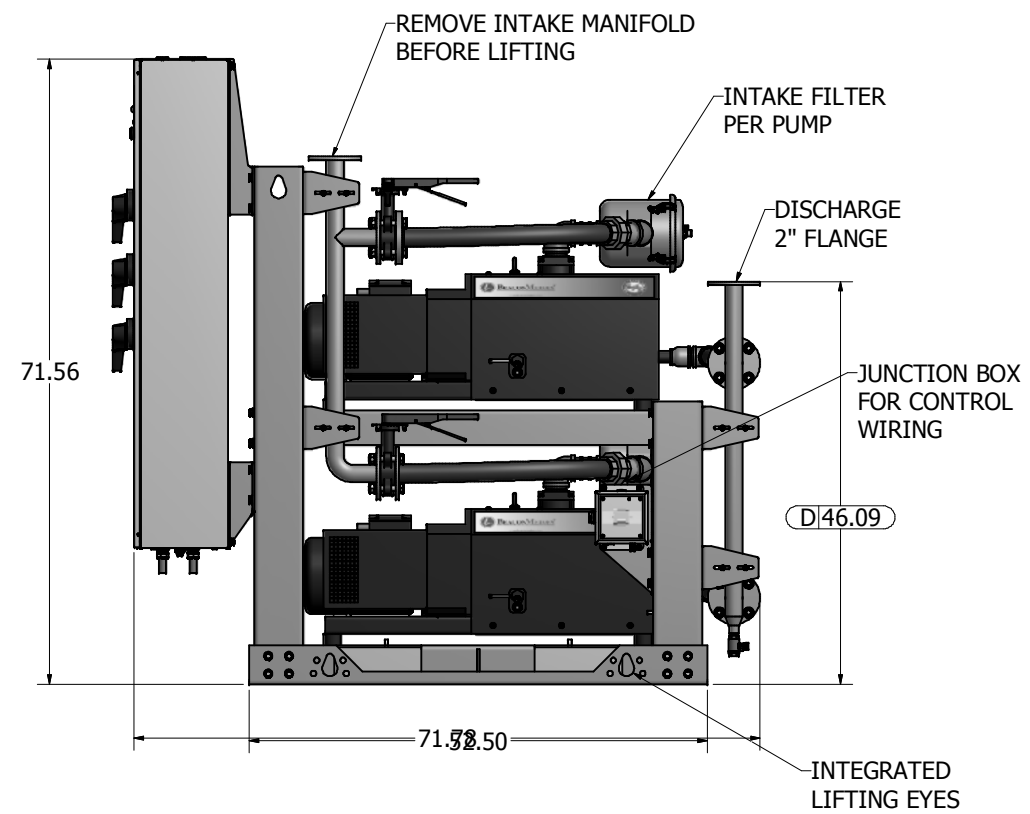
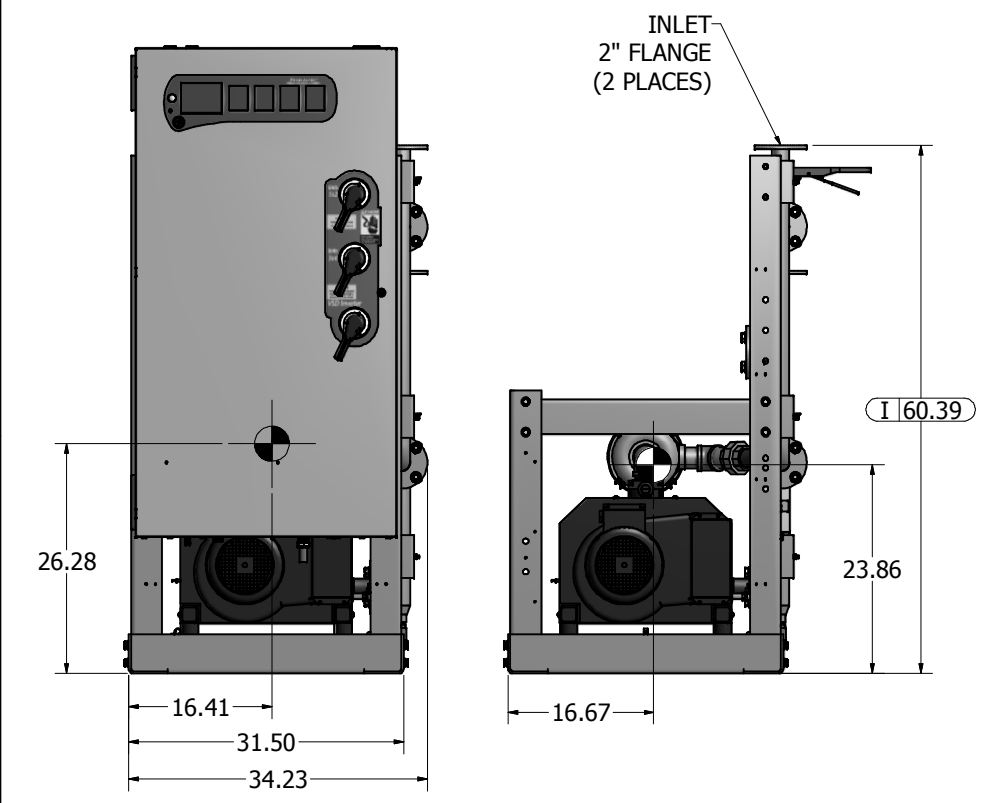
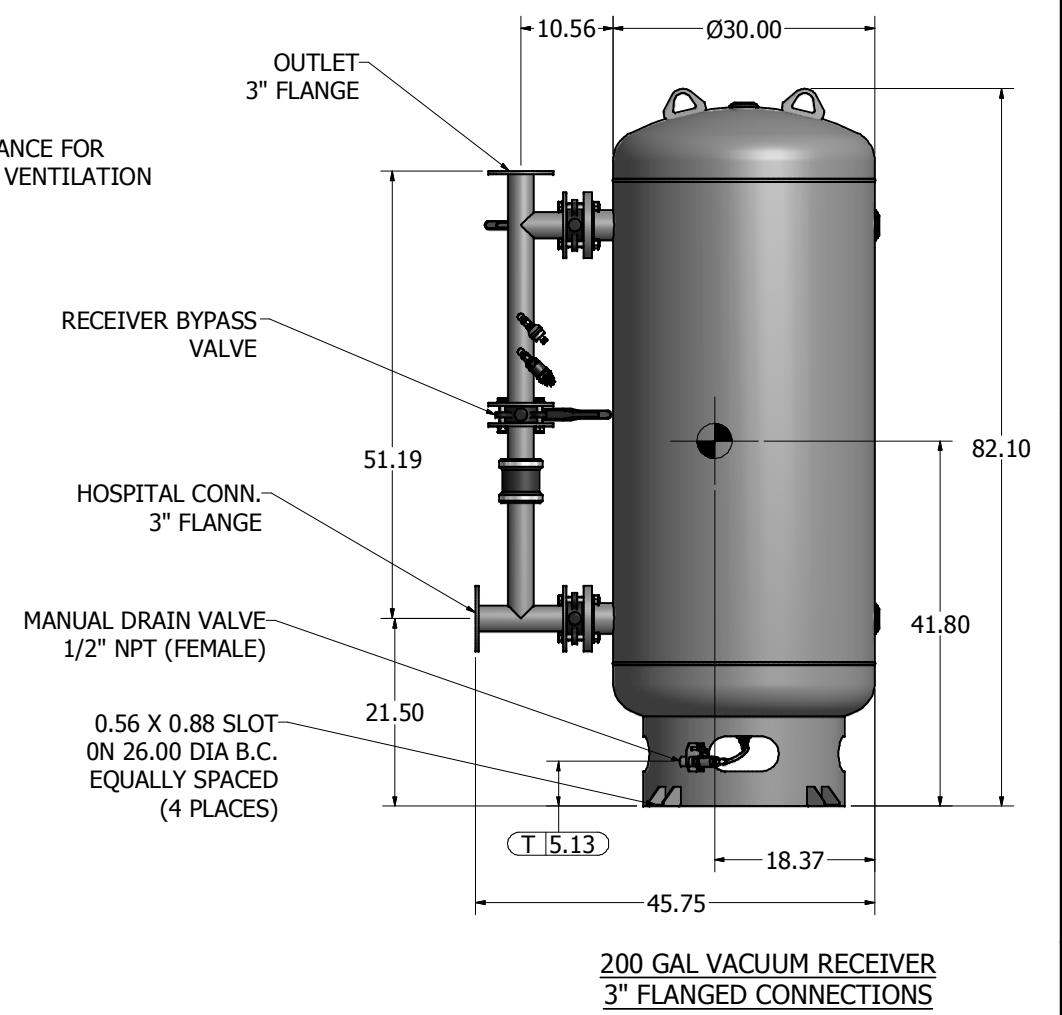
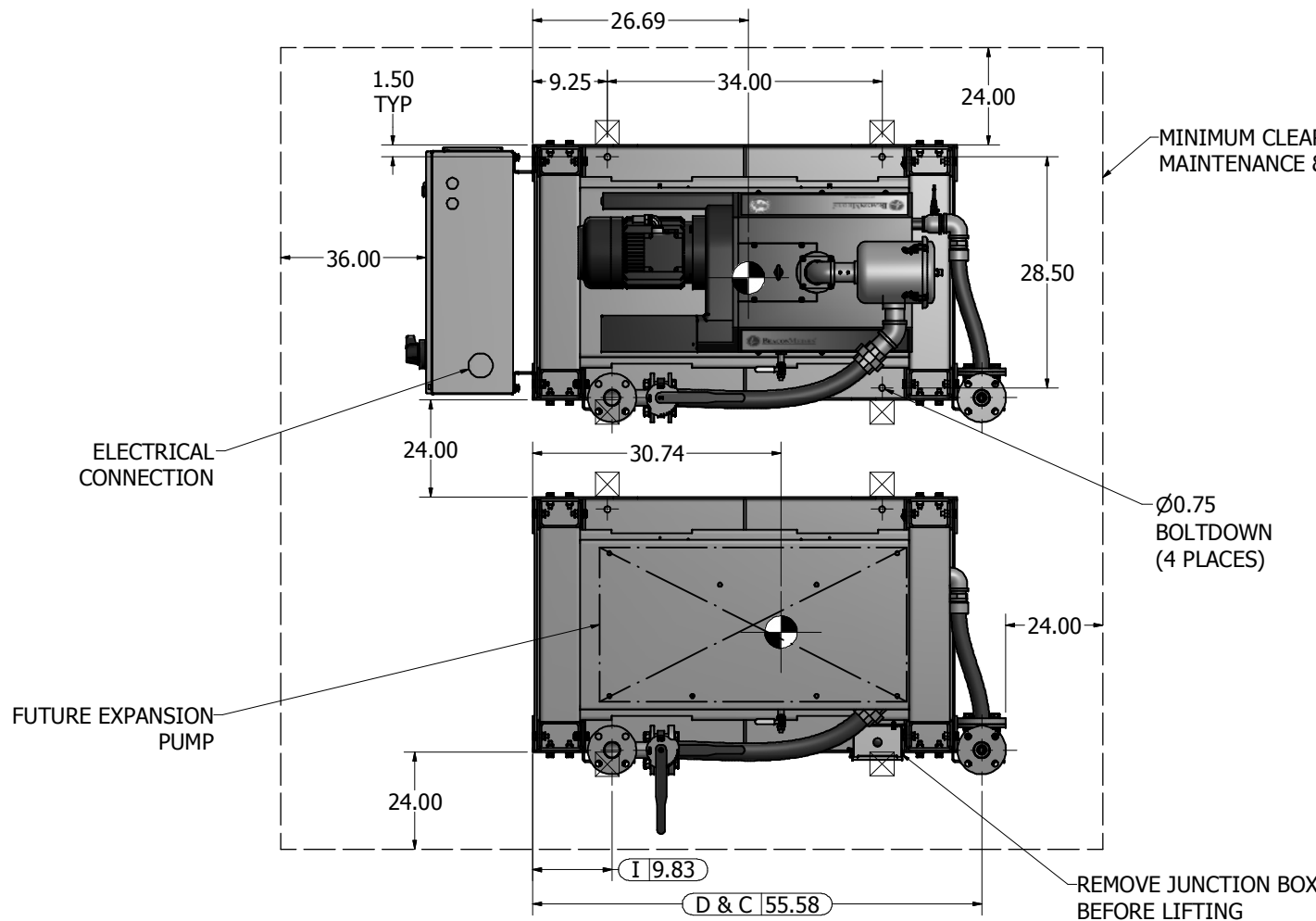

Revised:	Date:	Drawn: BJM	Date: 7/8/2010
UNLESS OTHERWISE SPECIFIED ALL DIMENSIONS ARE IN INCHES AND TOLERANCES ARE: XXX ± 0.2 XXXX ± 0.005 ANGLES ± 9°			
Description: GENERAL ASSEMBLY 7.5HP TX-X-QX CLAW VSD VAC MOD 200G RECEIVER STANDARD AND O2 ASSURED		Part Number: 4107 8515 61	Scale: 1:11
DN: USN100358	Rev: 00	Sheet 1 of 1	DO NOT SCALE THIS DOCUMENT