

- Notes:
1. DISCHARGE MUFFLER WILL BE SHIPPED LOOSE.
  2. PUMP MODULE WEIGHT: 2,005 LBS (INCLUDES FUTURE EXPANSION MODULE).  
120G TANK WEIGHT: 393 LBS.
  3. ☒ INDICATES LIFTING POINT.
  4. ● DENOTES CENTER OF GRAVITY (INCLUDES FUTURE EXPANSION MODULE).

SYSTEM CONNECTIONS	
ID	DESCRIPTION
I	INLET CONNECTION
D	DISCHARGE CONNECTION
C	CONDENSATE DRAIN CONNECTION
T	TANK DRAIN

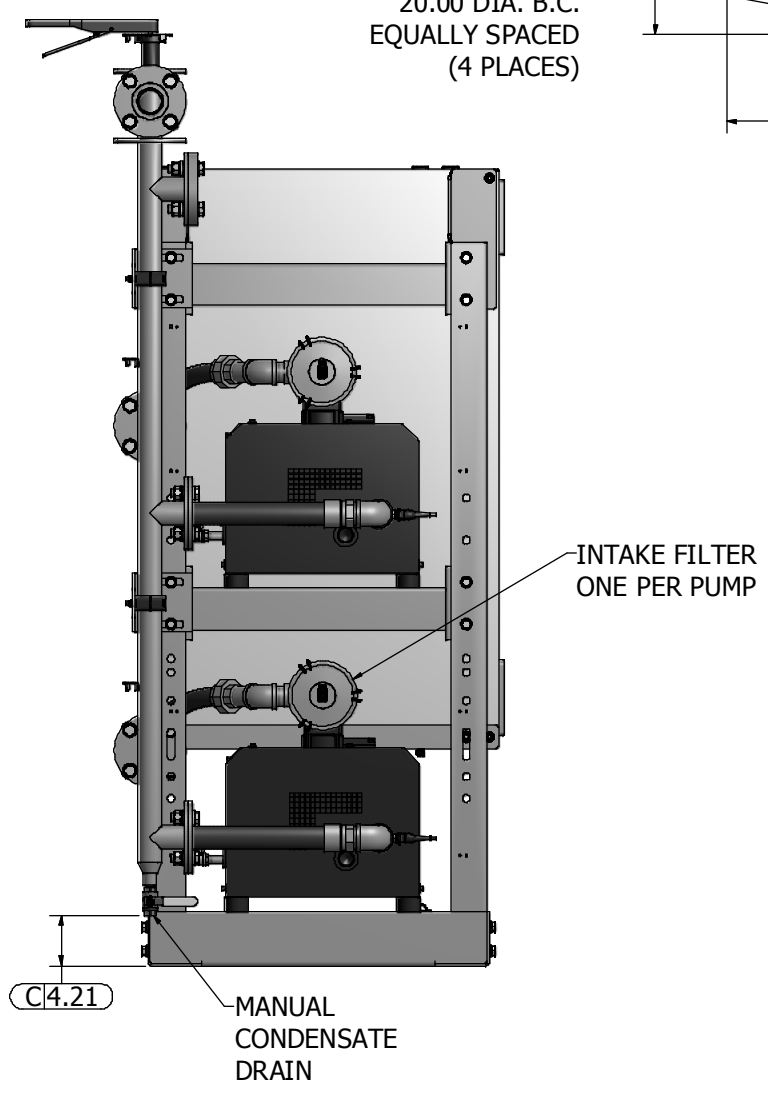
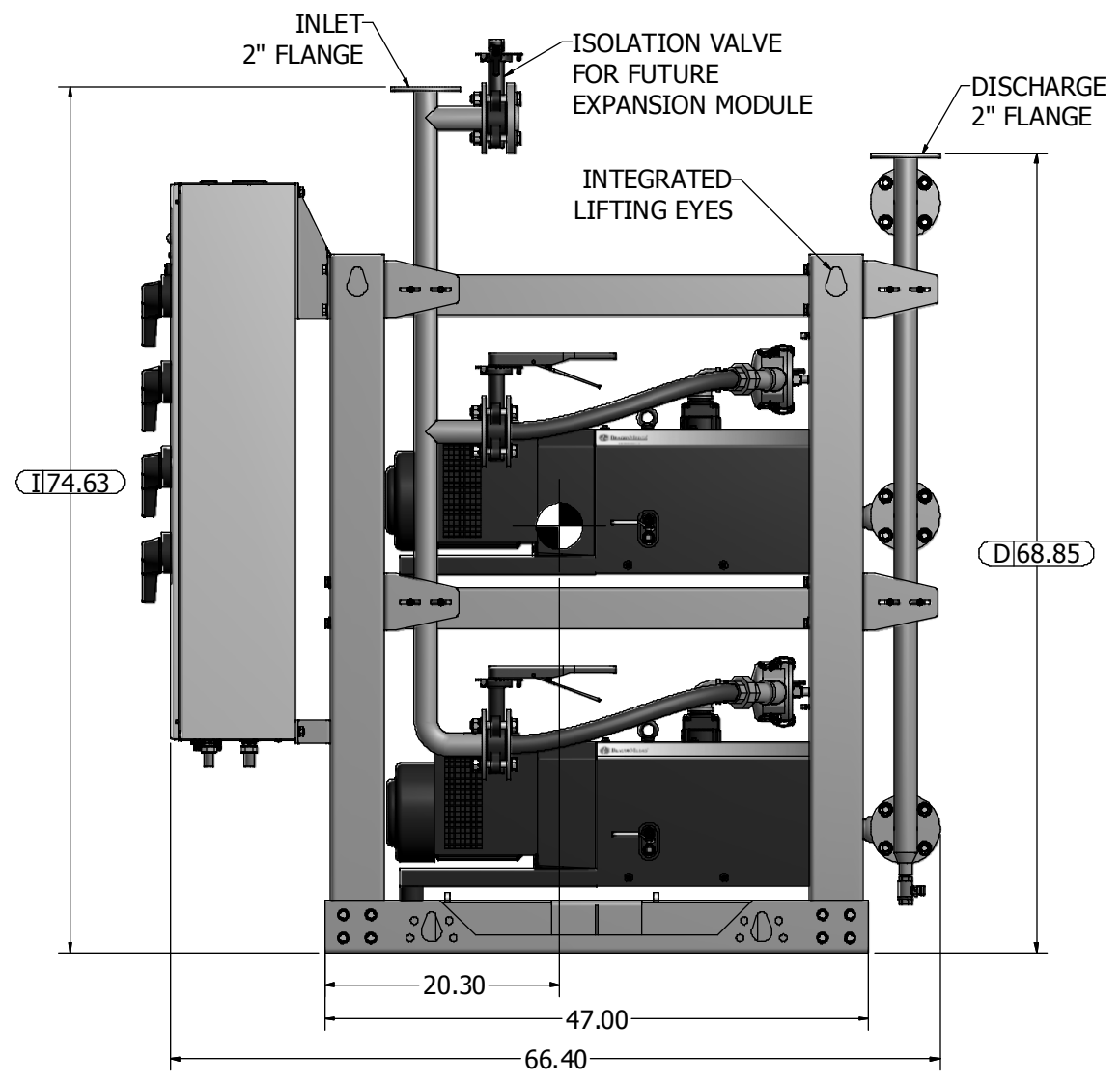
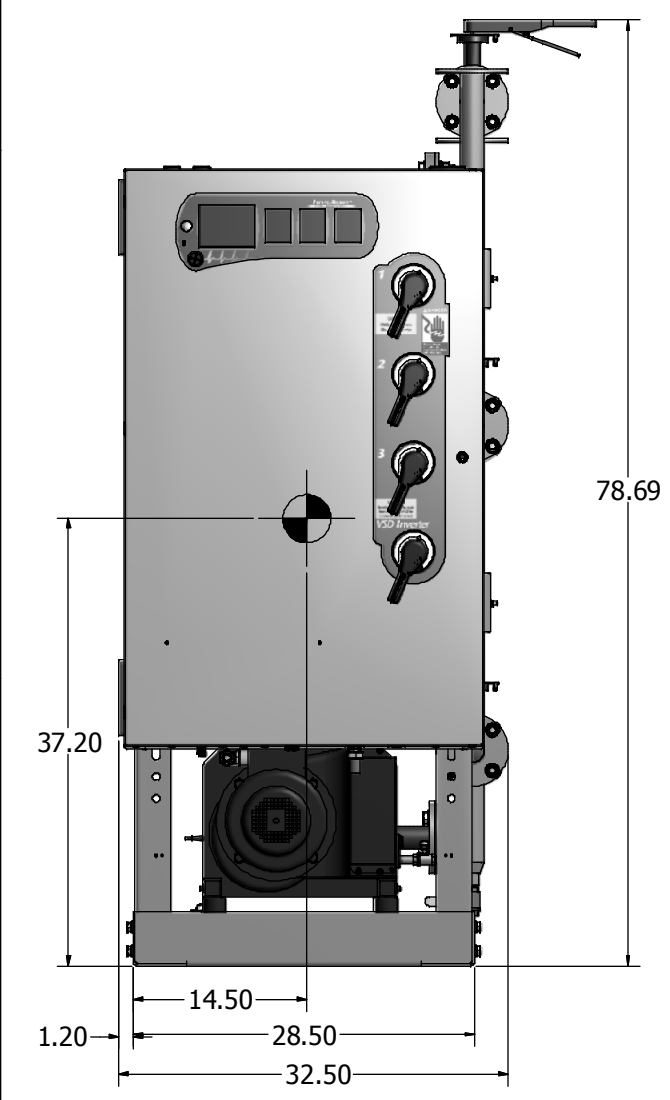
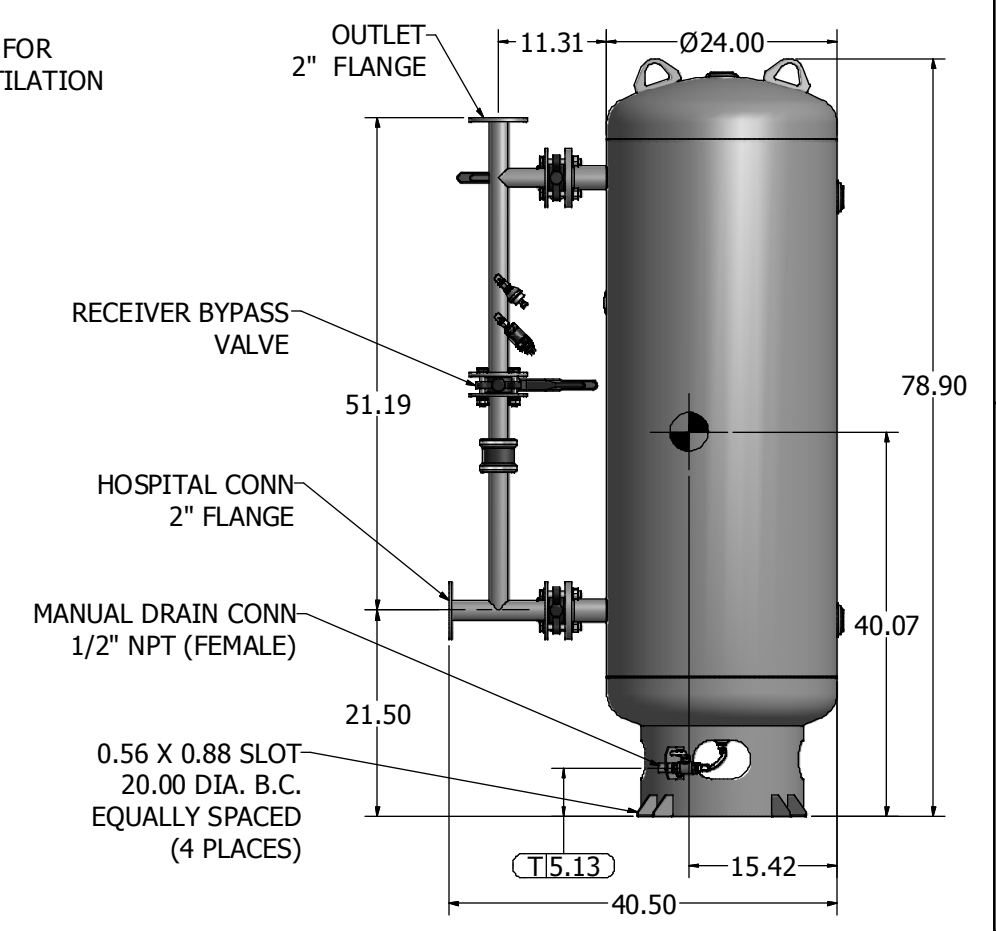
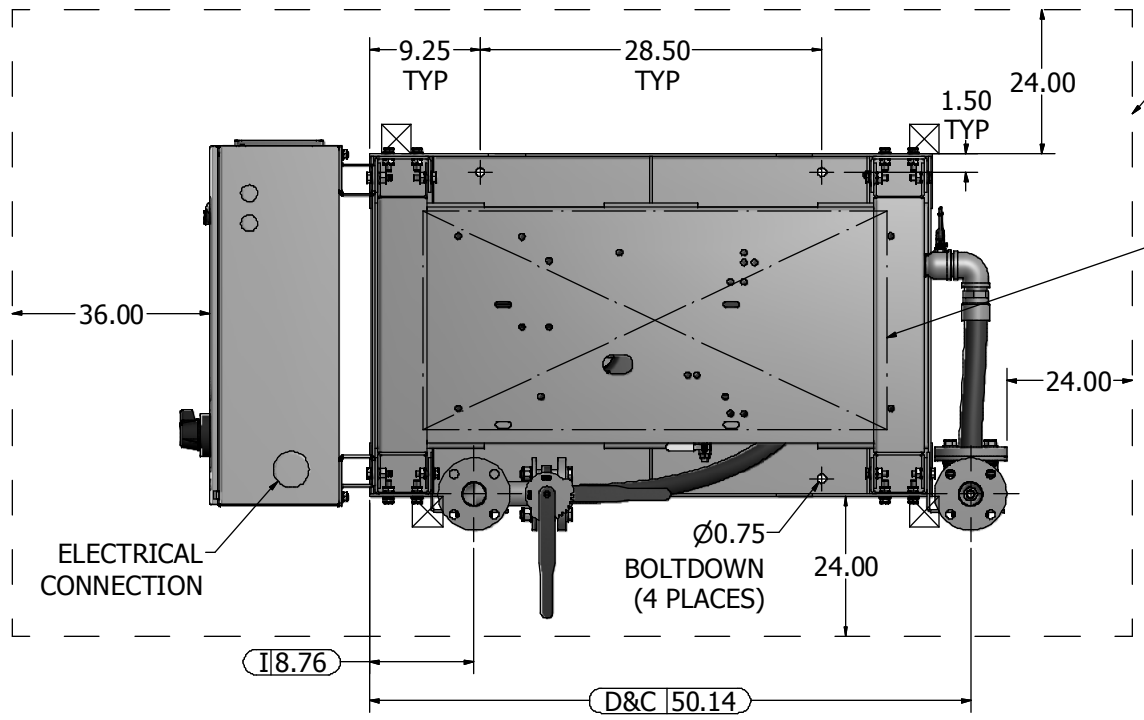

Revised:	Date:	Drawn:	Date:
		MDB	5/13/2010
		This drawing and the information contained therein remain the property of BeaconMedes and may not be used for other than the purpose for which it is loaned without the expressed written permission from BeaconMedes Engineering.	
Description: GENERAL ASSEMBLY 5.4HP DX-X-TX VSD CLAW VAC MOD 120G RECEIVER STANDARD AND O2 ASSURED		Part Number: 4107 8515 43	Scale: 1/8 <b>D</b>
DN: USN100352		Rev: 00	Sheet 1 of 1
Form F-007 Rev. 01		DO NOT SCALE THIS DOCUMENT	