

This drawing and the information contained thereon remain the property of BeaconMedes and may not be used for other than the purpose for which it is loaned without the expressed written permission from BeaconMedes Engineering.

Notes:

- DISCHARGE MUFFLERS WILL BE SHIPPED LOOSE.
- DX MODULE W/ PANEL WEIGHT: 1,877 LBS
DX MODULE WEIGHT: 1,671 LBS
240G TANK WEIGHT: 713 LBS
- ⊠ INDICATES LIFTING POINT.
- DENOTES CENTER OF GRAVITY.

SYSTEM CONNECTIONS	
ID	DESCRIPTION
I	INLET LOCATION
D	DISCHARGE LOCATION
C	CONDENSATE DRAIN LOCATION
T	TANK DRAIN LOCATION

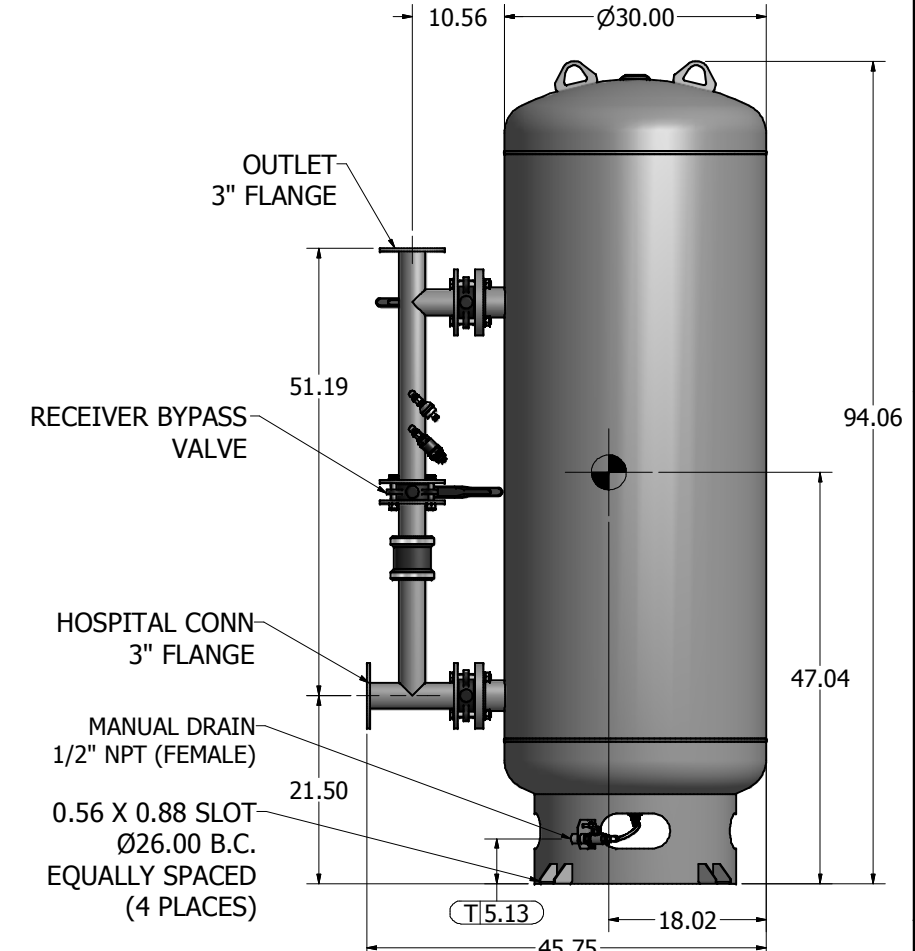
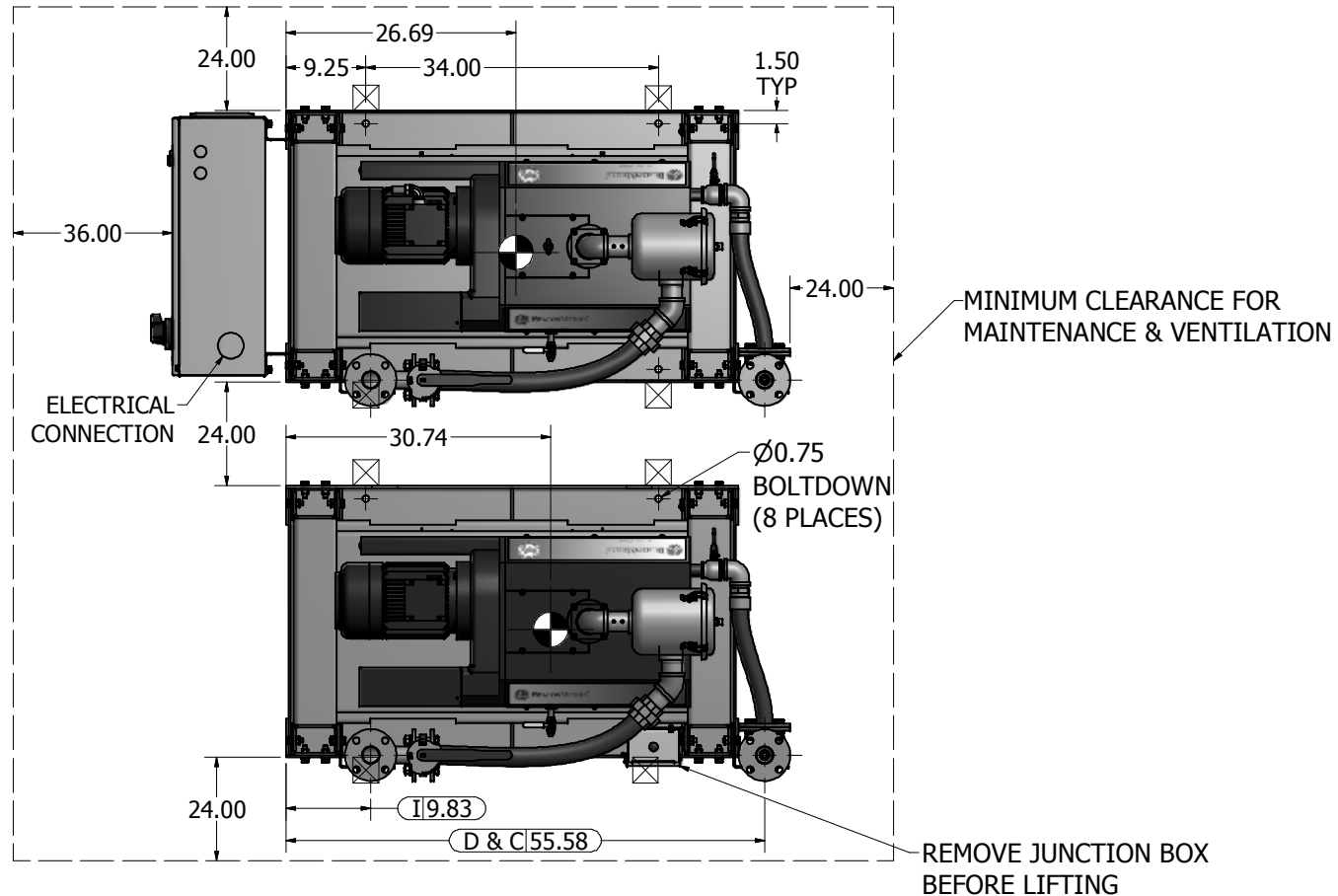

240 GAL VACUUM RECEIVER
3" FLANGED CONNECTIONS
(SCALE 1:11)

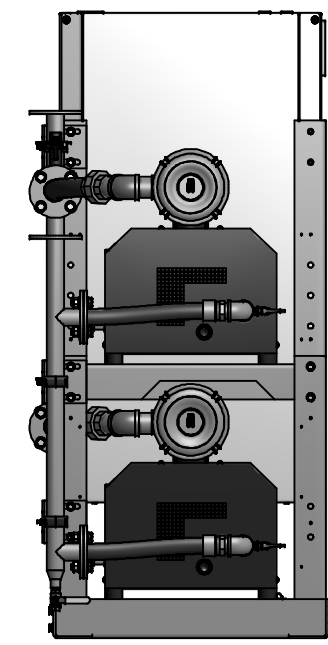
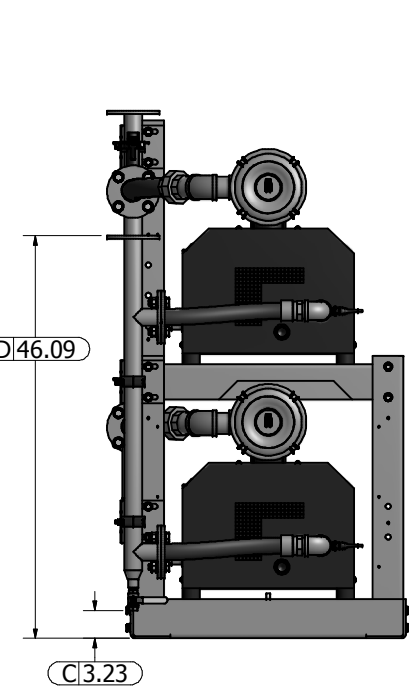
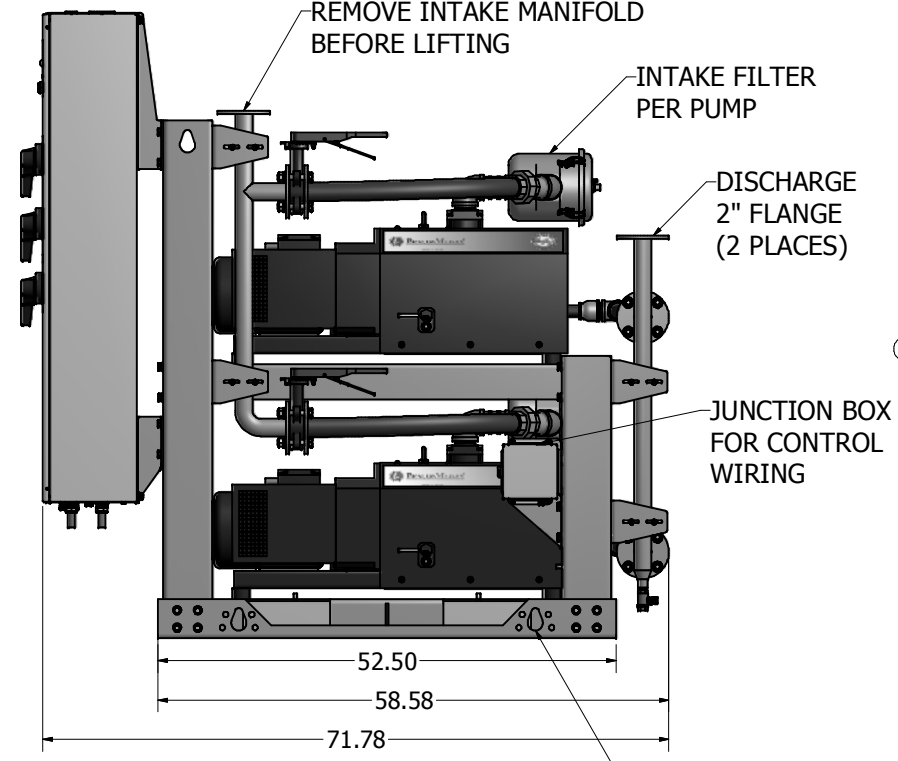
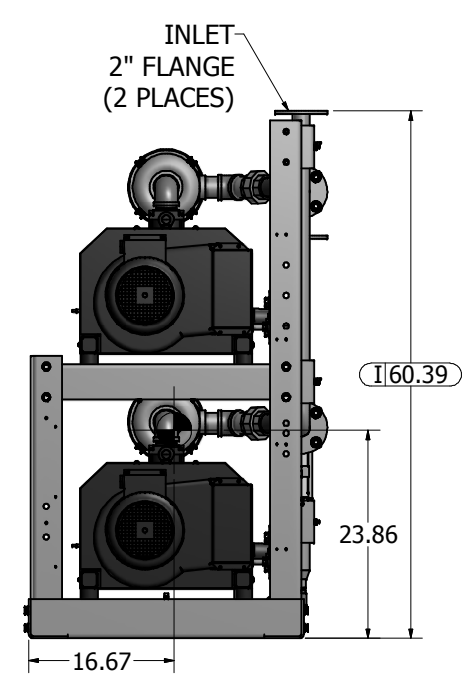
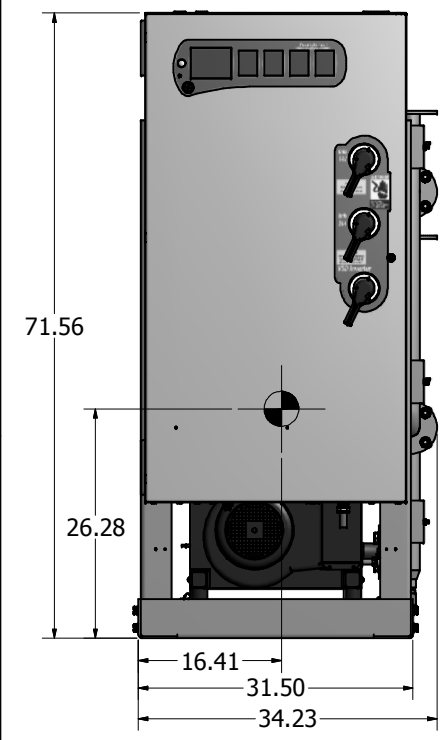

INSPECTION CHECKLIST UNLESS OTHERWISE SPECIFIED: ◊ ○ ALL ITEMS MARKED BY ONE OF THE ABOVE SYMBOLS ARE TO BE INSPECTED EQUIPMENT TO BE USED DURING RECEIVING INSPECTION SHALL BE PER QUALITY SYSTEM PROCEDURES	Revised: _____ Date: _____ Drawn: MDB Date: 4/15/2010
	UNLESS OTHERWISE SPECIFIED ALL DIMENSIONS ARE IN INCHES AND TOLERANCES ARE: XXX ±.02 XXXX ±.015 ANGLES ±.5°
BEACONMEDES	Scale: 1/11
Description: GENERAL ASSEMBLY 7.5HP QX CLAW VSD VAC MOD 240G RECEIVER STANDARD AND O2 ASSURED	Part Number: 4107 8514 31
DN: USN100301	Rev: 00
Sheet 1 of 1	DO NOT SCALE THIS DOCUMENT