

Notes:

- DISCHARGE MUFFLERS WILL BE SHIPPED LOOSE.
- DX MODULE W/ PANEL WEIGHT: 1,464 LBS
DX MODULE WEIGHT: 1,252 LBS
200G TANK WEIGHT: 638 LBS
- ☒ INDICATES LIFTING POINT.
- DENOTES CENTER OF GRAVITY.

SYSTEM CONNECTIONS	
ID	DESCRIPTION
I	INLET LOCATION
D	DISCHARGE LOCATION
C	CONDENSATE DRAIN LOCATION
T	TANK DRAIN LOCATION

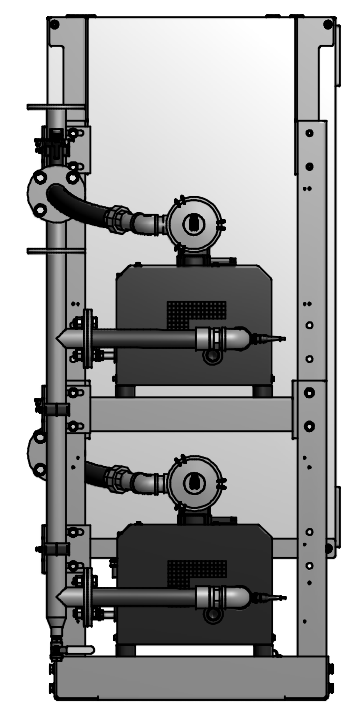
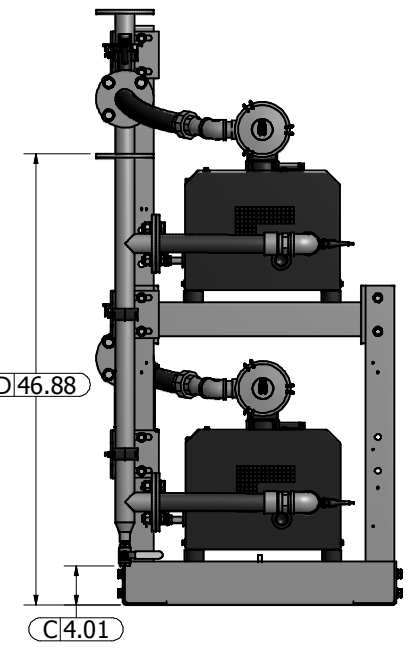
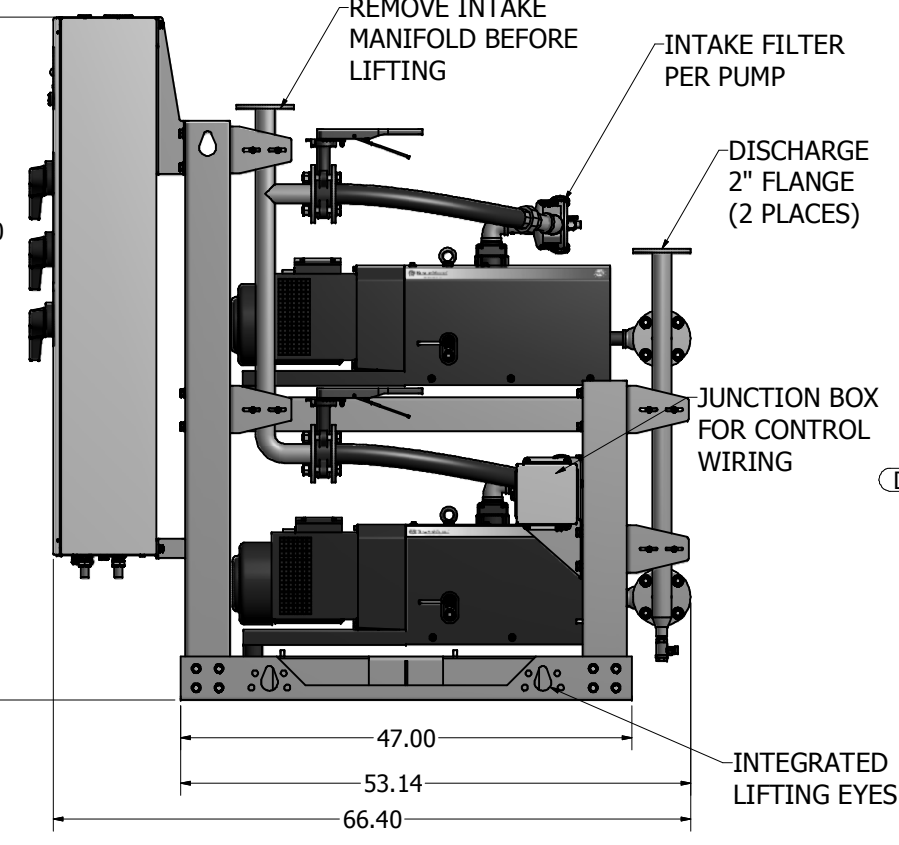
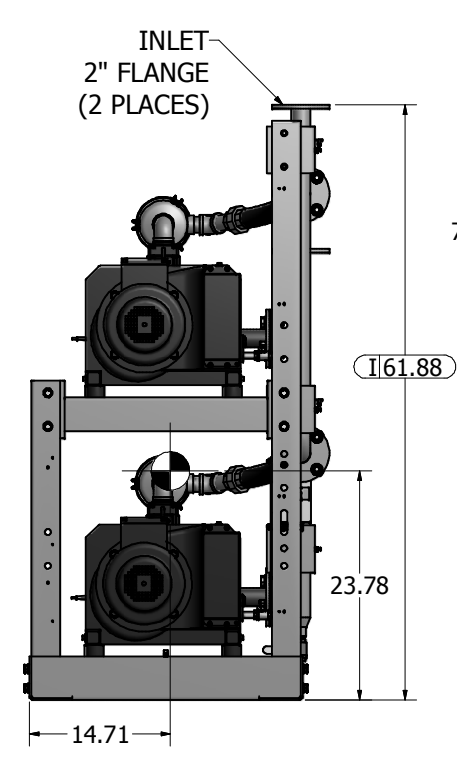
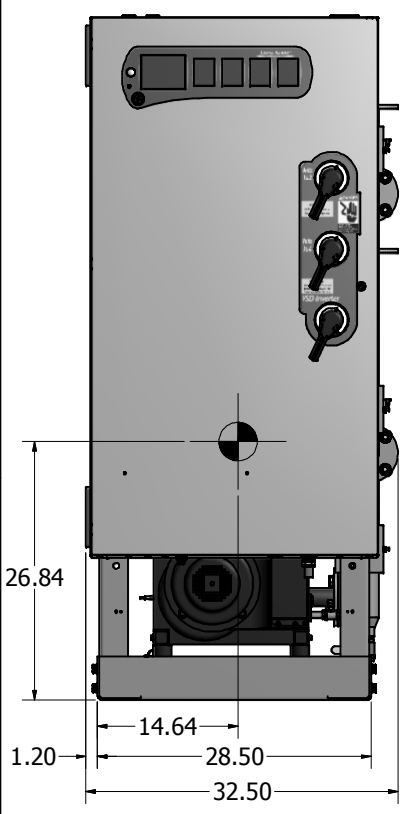
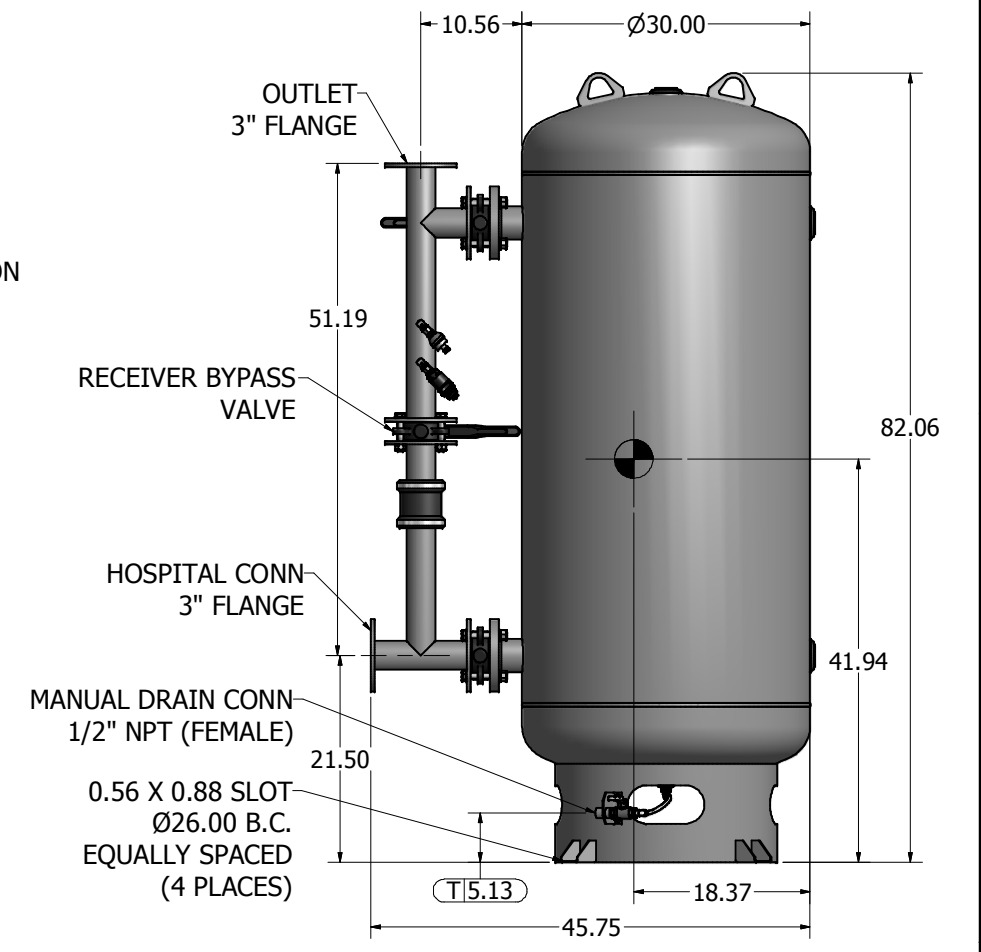
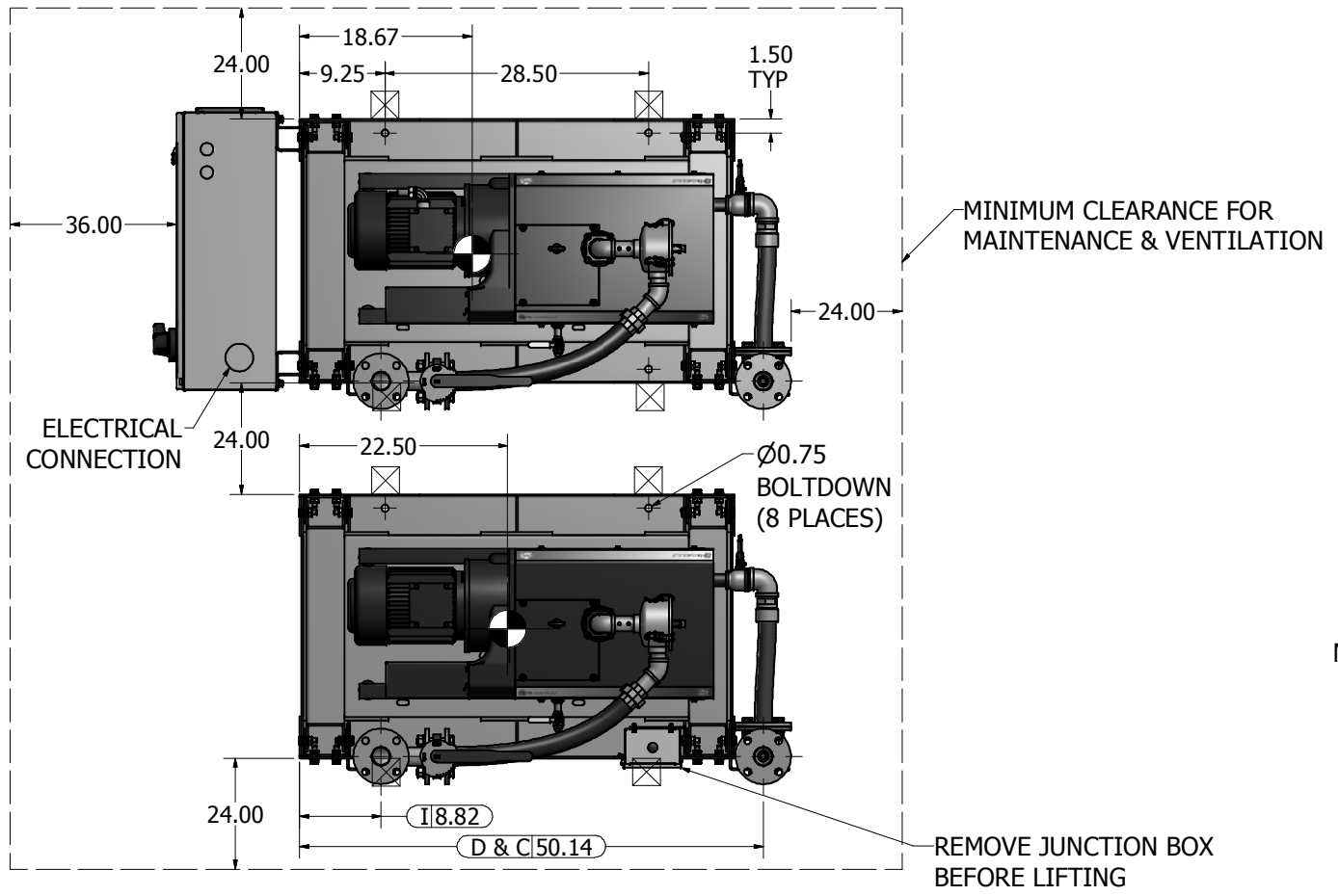

Revised:	Date:	Drawn: BJM	Date: 6/21/2010
		This drawing and the information contained therein remain the property of BeaconMedes and may not be used for other than the purpose for which it is loaned without the expressed written permission from BeaconMedes Engineering.	
Description: GENERAL ASSEMBLY 5.4HP QX CLAW VSD VAC MOD 200G RECEIVER STANDARD AND O2 ASSURED		Part Number: 4107 8514 26 DN: USN100301 Rev: 00 Sheet 1 of 1 DO NOT SCALE THIS DOCUMENT	
		Scale: 1/10 D	