

Notes:

- DISCHARGE MUFFLER WILL BE SHIPPED LOOSE.
- TX MODULE WEIGHT: 2,005 LBS  
200G TANK WEIGHT: 618 LBS
- ☒ INDICATES LIFTING POINT.
- DENOTES CENTER OF GRAVITY.

SYSTEM CONNECTIONS	
ID	DESCRIPTION
I	INLET LOCATION
D	DISCHARGE LOCATION
C	CONDENSATE DRAIN LOCATION
T	TANK DRAIN LOCATION

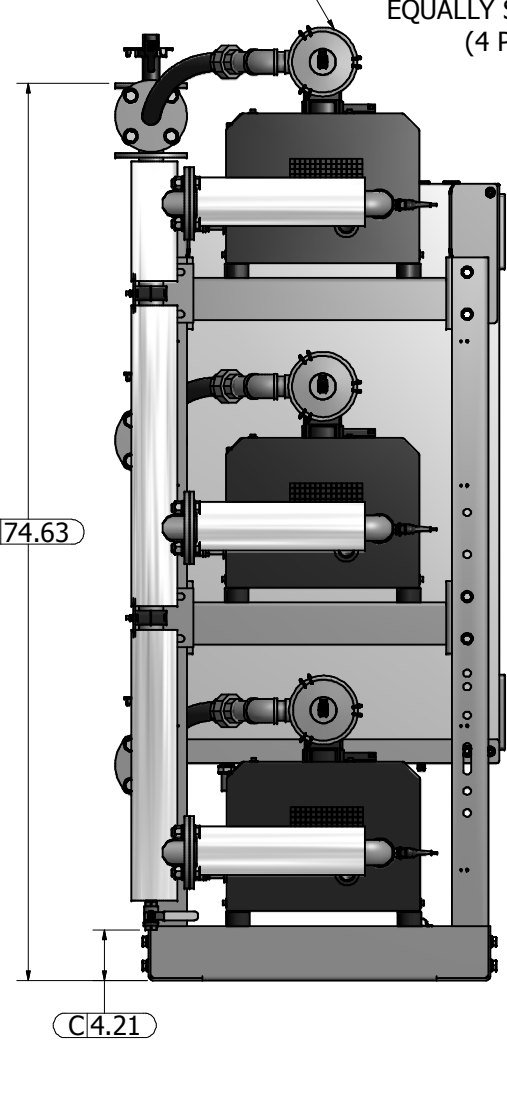
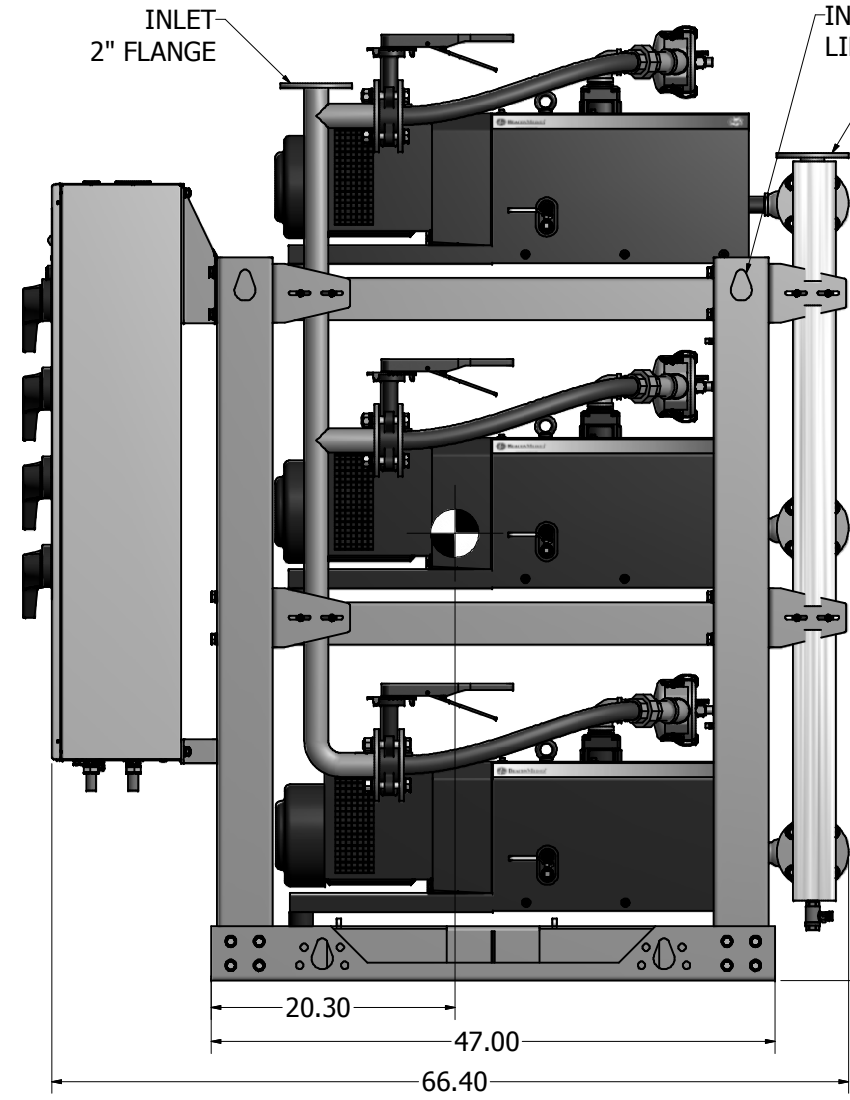
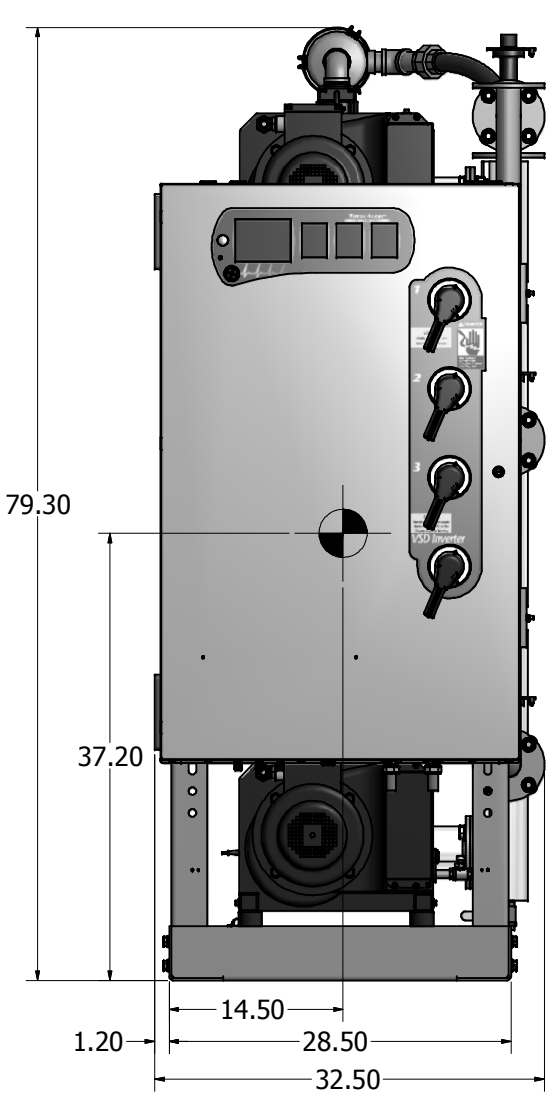
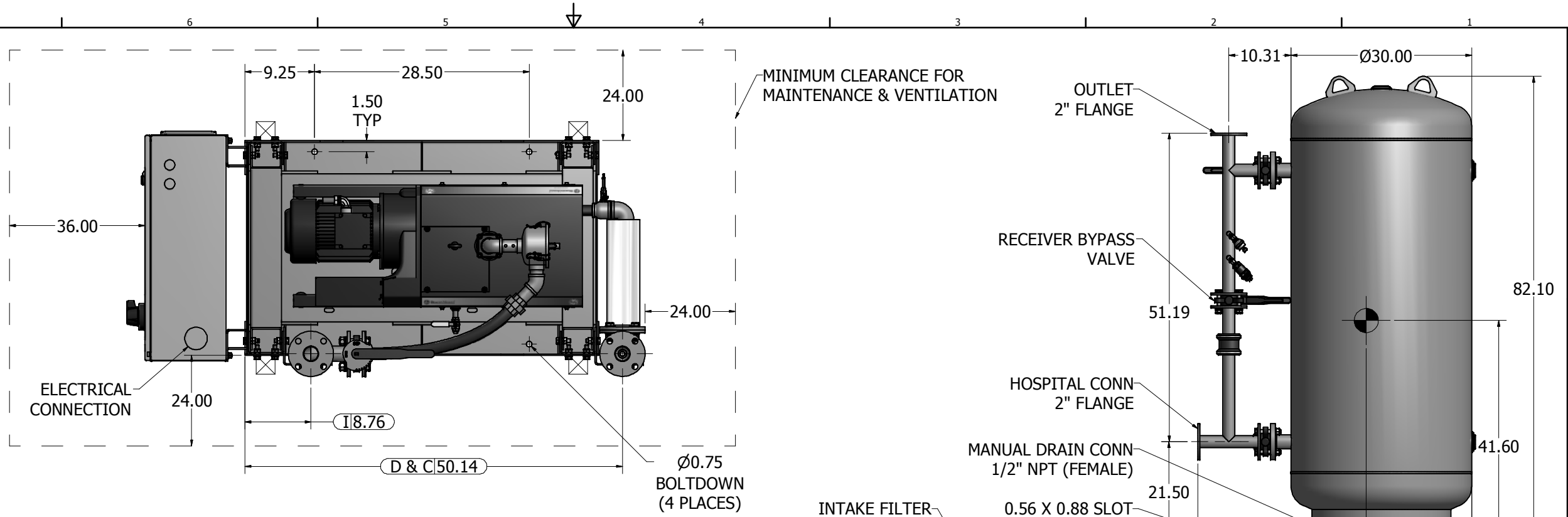

200 GAL VACUUM RECEIVER  
2" FLANGED CONNECTIONS  
(SCALE 1:10)

Revised:	Date:	Drawn: usnbw	Date: 3/30/2010
		This drawing and the information contained therein remain the property of BeaconMedes and may not be used for other than the purpose for which it is loaned without the expressed written permission from BeaconMedes Engineering.	
Description: GENERAL ASSEMBLY 5.4HP TX CLAW VSD VAC MOD 200G RECEIVER STANDARD AND O2 ASSURED		Part Number: 4107 8514 13	Scale: 1:8 D
DN:	Rev:	00	
Sheet 1 of 1	DO NOT SCALE THIS DOCUMENT		