

- Notes:
- DISCHARGE MUFFLER WILL BE SHIPPED LOOSE.
 - PUMP MODULE WEIGHT: 2,606 LBS (INCLUDES FUTURE EXPANSION PUMP).
240G TANK WEIGHT: 713 LBS.
 - ⊠ INDICATES LIFTING POINTS
 - DENOTES CENTER OF GRAVITY (INCLUDES FUTURE EXPANSION PUMP).

SYSTEM CONNECTIONS	
ID	DESCRIPTION
I	INLET CONNECTION
C	DISCHARGE CONNECTION
D	CONDENSATE DRAIN CONNECTION
T	TANK DRAIN

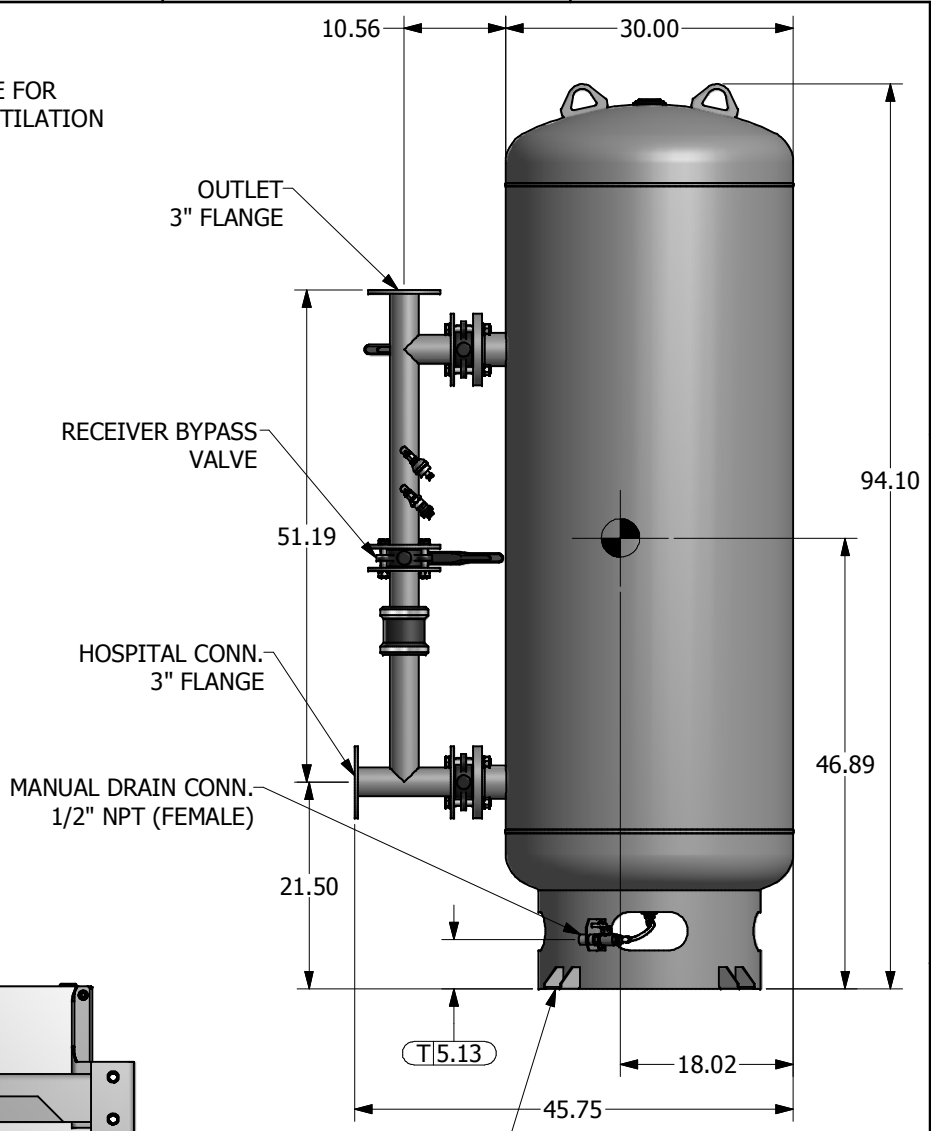

240 GAL VACUUM RECEIVER
3" FLANGED CONNECTIONS
(SCALE 1:10)

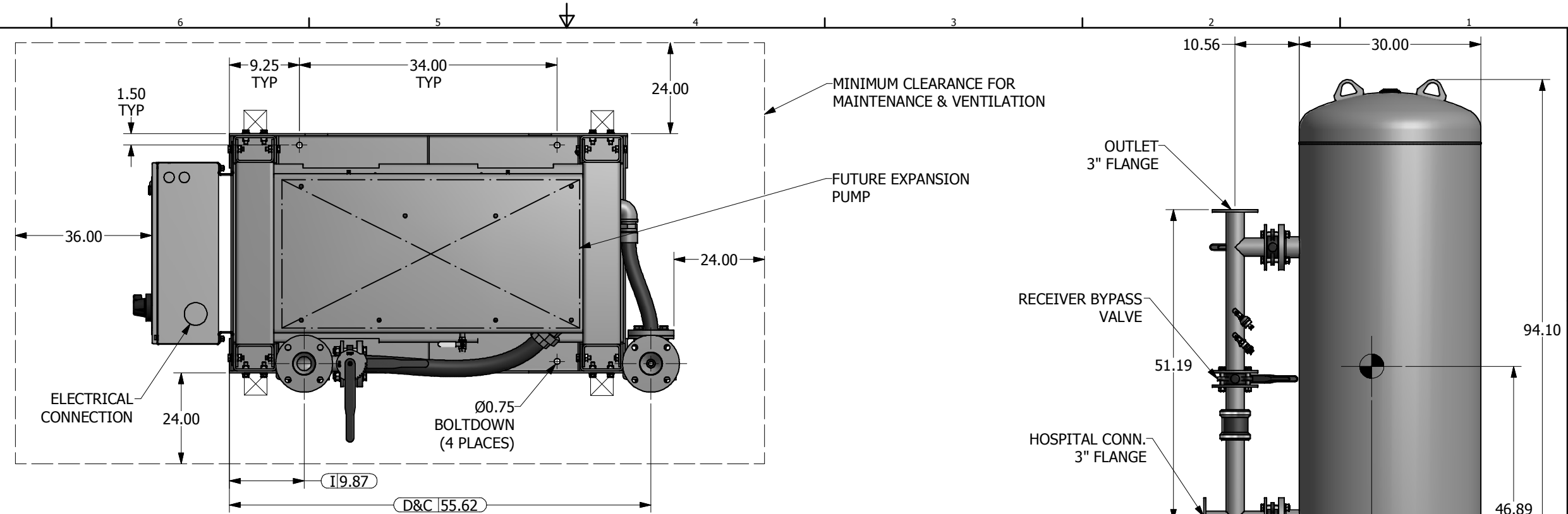
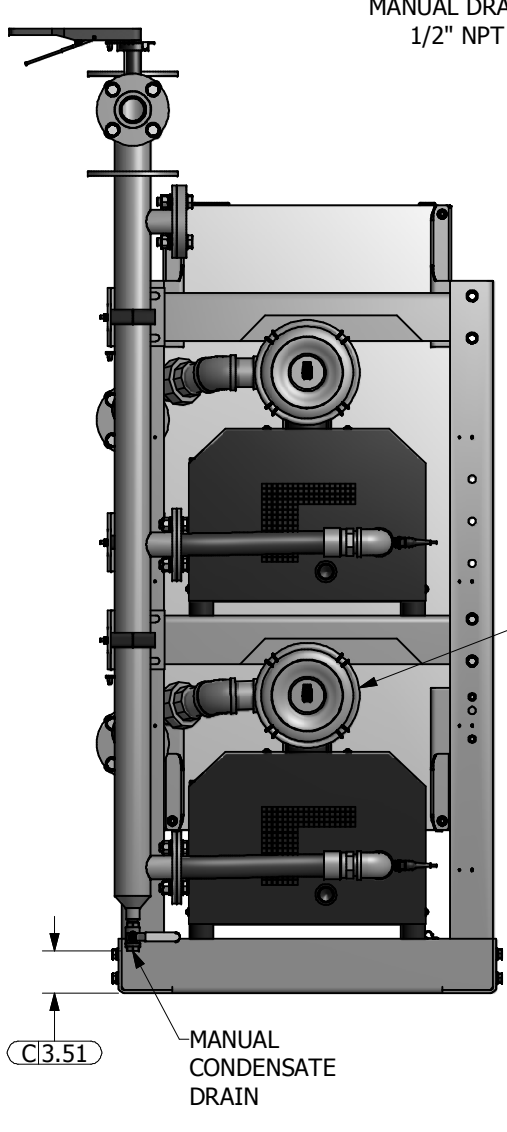
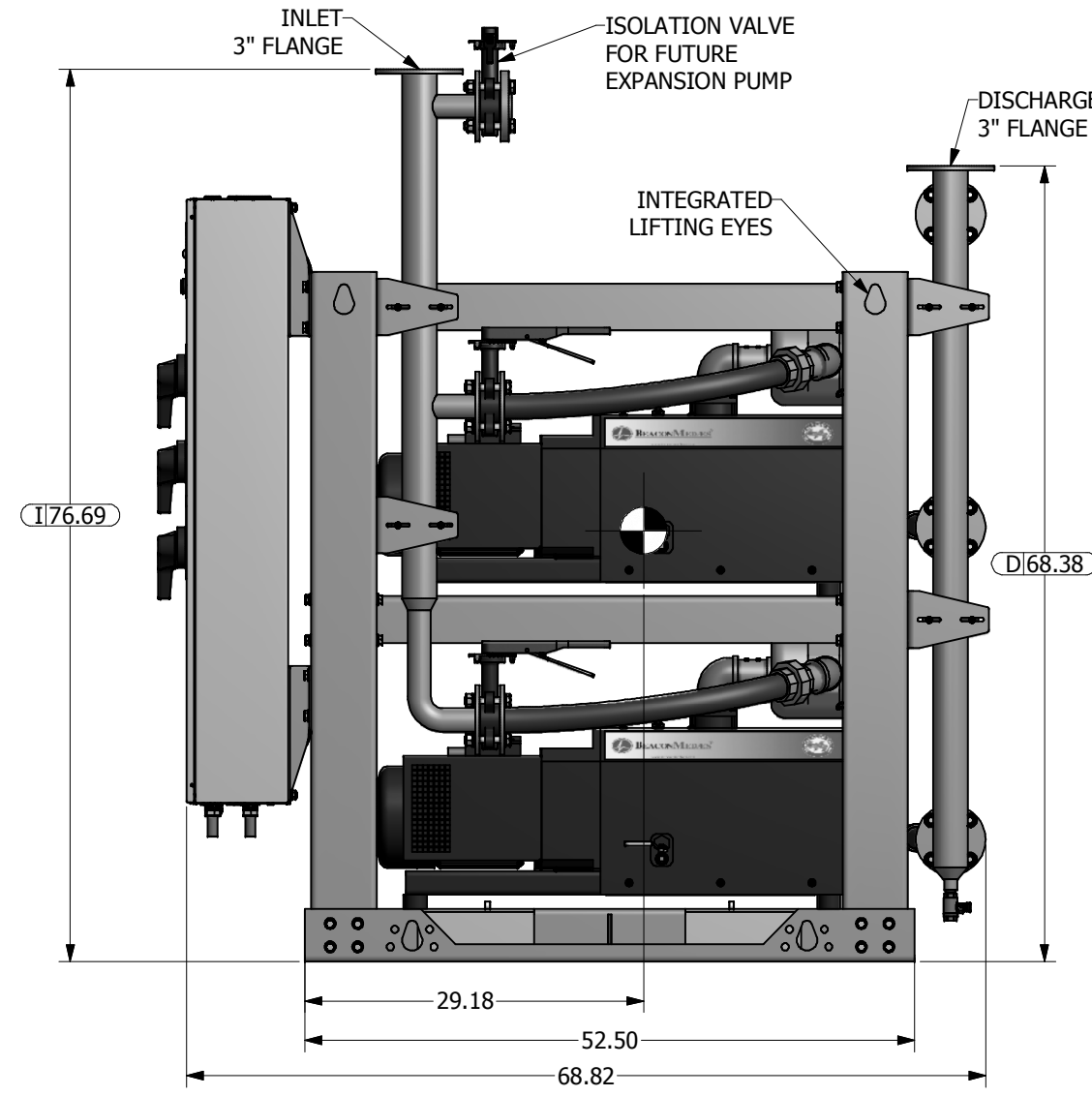
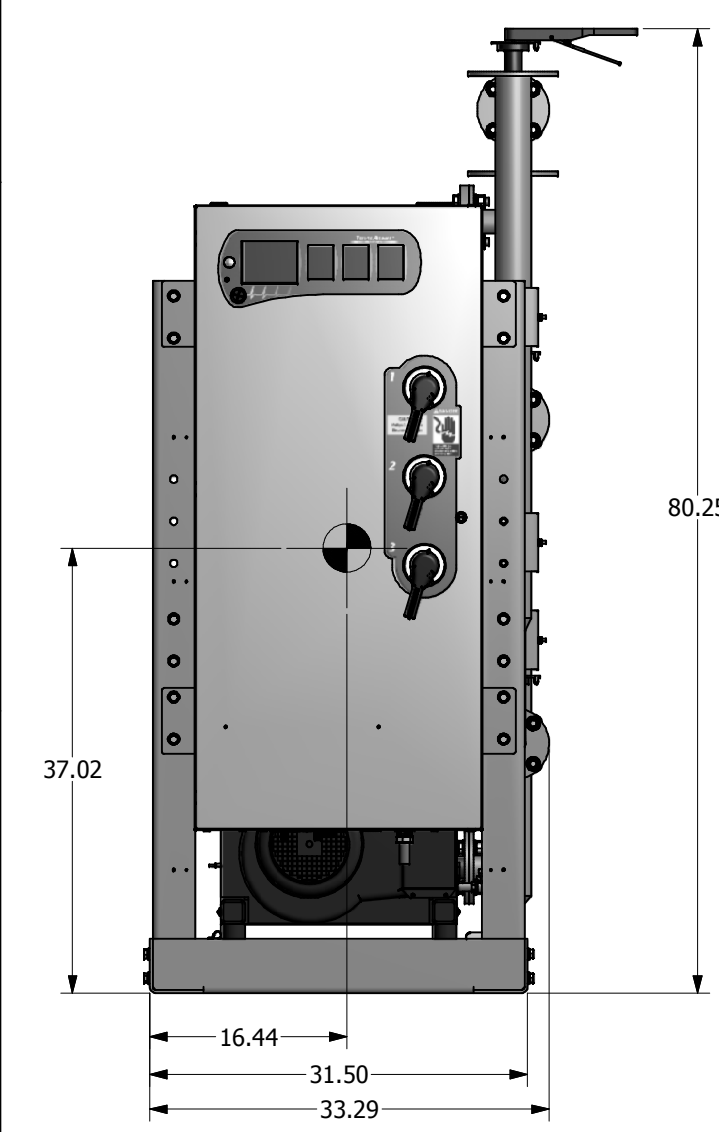

INTAKE FILTER
ONE PER PUMP

Revised:	Date:	Drawn:	Date:
		bm	5/12/2010
		This drawing and the information contained therein remain the property of BeaconMedes and may not be used for other than the purpose for which it is loaned without the expressed written permission from BeaconMedes Engineering.	
Description: GENERAL ASSEMBLY 6.4HP DX-X-TX CLAW VAC MOD 240G RECEIVER STANDARD AND O2 ASSURED		Part Number: 4107 8514 88	Scale: 1:8 D
DN: USN100235		Rev: 00	Sheet 1 of 1
Form F-007 Rev. 01		DO NOT SCALE THIS DOCUMENT	