



Zone Valve Box Installation Instructions

Valve box assemblies should be installed at specified locations per NFPA 99, Standard for Health Care Facilities or CAN/CSA-Z7396.1, Canadian Standard for Nonflammable Medical Gas Piping Systems or AS 2896, Australian Standard for Medical Gas Systems.

All valves are supplied clean for oxygen service. Care should be taken to keep debris out of valves and pipelines during installation.

Step 1: Location

Plan sufficient space to accommodate valve box assembly allowing access door to slide to right. There must be no obstruction adjacent to box to prevent sliding of door.

Step 2: Secure Box to Structural Supports

Secure box mounting brackets, located on top and bottom of box, to wall structural frame supports (supplied by others). Position valve box so front edge of box is flush to 1/4" below finished wall surface. Box should be level and installed at specified height/location on wall.

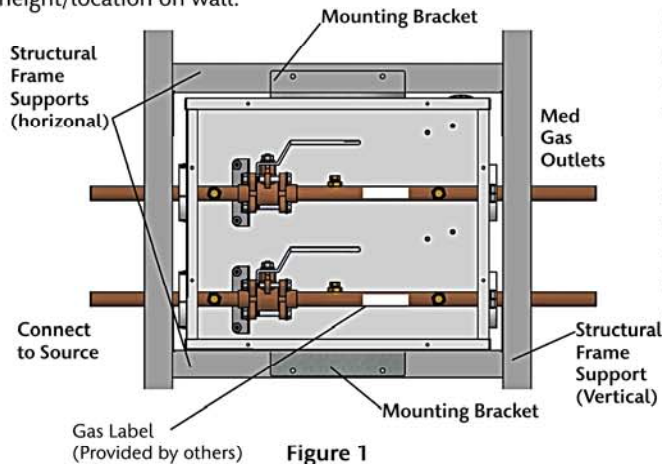

Figure 1

Step 3: Connect Valves to System Piping

Piping to be connected as shown in Figure 1. Braze tube extensions to piping system, per NFPA 99, while using heat sink techniques appropriate for protection of sealing materials in both valve and gauge port plug. Unbolting and removing valve for heat protection during installation is not recommended. During brazing, joints shall be continuously purged with oil-free dry nitrogen. Slide plastic grommets as close to the center of the Zone Valve Box before brazing to avoid heat damage. Move grommets back to original location after piping has cooled.

Caution: Excessive heat may destroy valve seals. If damage occurs, repair kit must be installed.

Step 4: Gas Service Identification

Install appropriate label on each valve in box assembly. Refer to Figure 1. Labels to be provided by others.

Step 5: Standing Pressure Test

Perform standing pressure test on each system as specified by NFPA 99, CSA-Z7396.1 or AS 2896.

Caution: Do not install gauge before pressure test.

Step 6: Dust Cover

After system pressure test has been completed, re-install dust cover, supplied with valve box, to keep out dirt and debris during wall finishing.

Step 7: Gauge Installation (after walls are finished)

When gauge is required, remove gauge port plug from valve tube extension. Install gauge using Teflon tape or oxygen compatible sealant on gauge threads. Be certain gauge is positioned upright for ease of observation. Refer to Figure 2.

Caution: Ensure no pressure in pipe before removing plug.



Figure 2

Step 8: Install Trim Frame and Door

Install trim frame with open edge properly oriented to allow door to slide to the right side. Secure trim frame in place with eight screws provided. (Max Torque is 4 in lbs) Slide door in place by inserting into open side of trim frame. Refer to Figure 3.

For emergency access, door can be removed completely by pulling ring on door.

Step 9: Gas Identification and Location Labels

Install appropriate gas identification label for each valve at location provided on label holder. Mark location served by each valve on the label provided. Refer to Figure 3.

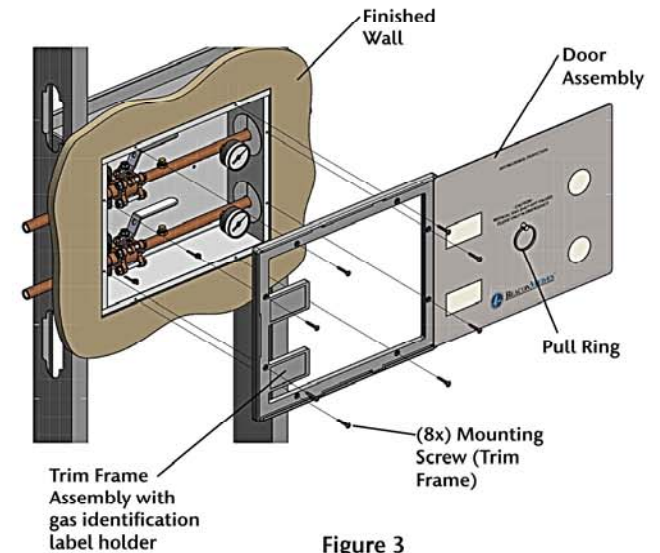

Figure 3