

Notes:

1. MAIN DISCONNECT PROVIDED BY OTHER.
2. FIELD WIRING TO BE COPPER RATED FOR 75°C MINIMUM.
3. - - - - INDICATES FIELD WIRING OUTSIDE OF CABINET.
4. AUXILIARY CONTACTS LIST ON SHEET 4.
5. THE AMPACITY OF CONDUCTORS SUPPLYING THE CONTROL PANEL TO BE ROUNDED UP TO THE NEXT SIZE STANDARD WIRE GAUGE.
6. MOP VALUES TO BE ROUNDED DOWN TO THE NEAREST STANDARD RATING OF THE OVERCURRENT PROTECTION DEVICE.
7. SHORT CIRCUIT CURRENT RATING (SCCR): 5 kA

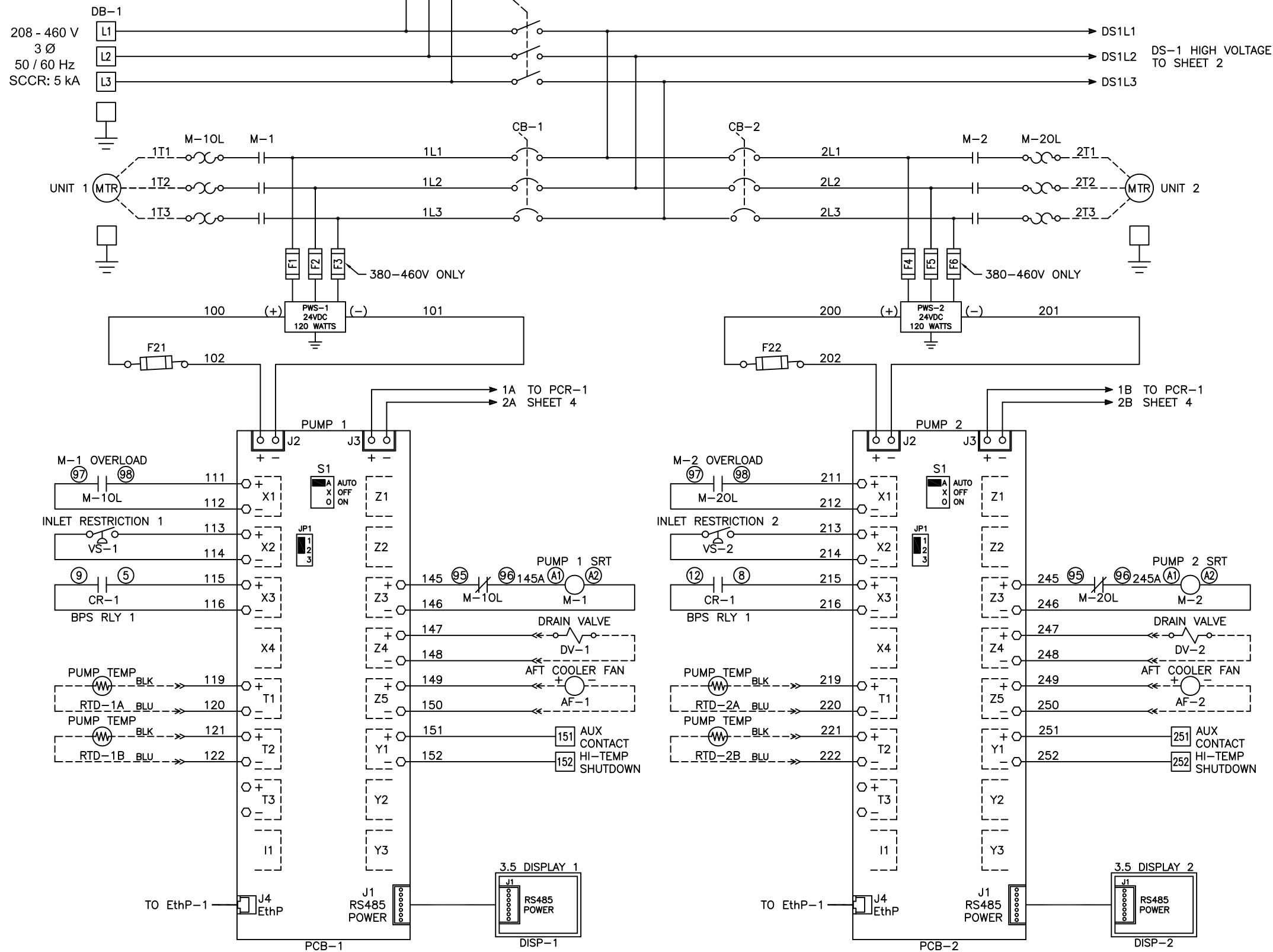

MINIMUM CIRCUIT AMPACITY (MCA)

SYSTEM HP	208 V	230 V	380/415 V	460 V
15 HP	294.0 AMPS	267.2 AMPS	172.5 AMPS	134.3 AMPS

MAXIMUM OVERCURRENT PROTECTION (MOP)

SYSTEM HP	208 V	230 V	380/415 V	460 V
15 HP	335.0 AMPS	304.5 AMPS	195.8 AMPS	152.3 AMPS

HEXAPLEX SYSTEM FULL LOAD AMPERES

SYSTEM HP	208 V	230 V	380V/50Hz	415V/50Hz	460 V
15 HP	220.2 AMPS	213.8 AMPS	126.0 AMPS	121.8 AMPS	107.5 AMPS

INDIVIDUAL FULL LOAD AMPERES

SYSTEM HP	208 V	230 V	380V/50Hz	415V/50Hz	460 V
15 HP	36.0 AMPS	35.0 AMPS	20.5 AMPS	19.8 AMPS	17.5 AMPS

FUSE SELECTION CHART (MAX FUSE SIZES SHOWN)

FUSES	208 V	230 V	380 V	415 V	460 V
F1/F2/F4/F5 F7/F8/F10 F11/F13/F14 F16/F17	6.0 AMPS	6.0 AMPS	6.0 AMPS	6.0 AMPS	6.0 AMPS
F3/F6/F9 F12/F15/F18	---	---	6.0 AMPS	6.0 AMPS	6.0 AMPS
F21-F26	4.0 AMPS	4.0 AMPS	4.0 AMPS	4.0 AMPS	4.0 AMPS
F31/F32 F33/F34	1.0 AMP	1.0 AMP	1.0 AMP	1.0 AMP	1.0 AMP
F35/F36	0.5 AMP	0.5 AMP	0.5 AMP	0.5 AMP	0.5 AMP

F1-F18 ARE LITTELFUSE KLDK 600V TYPE
F21-F26/F31-F36 ARE LITTELFUSE 2AG 250V TYPE

DEFAULT PUMP PSI SETTINGS

PUMP SEQUENCE	PSI
LEAD CUT-OFF	110
LAG CUT-ON	85

BACKUP PRESSURE SWT SETTINGS

BPS-1 CUT-OFF	PSI
BPS-1 CUT-OFF	105
BPS-1 CUT-ON	80

PUMP/DRYER PCB JUMPER/SWT SETTINGS

JPR/SWT	POSITION
JP1	1-2
S1	A (AUTO)

AUTO OPERATION:

DURING NORMAL OPERATION, THE MASTER PCB WILL SIGNAL THE LEAD COMPRESSOR TO START WHEN THE PRESSURE FALLS BELOW THE SET-POINT FOR THE LEAD PUMP. IF ONE PUMP CAN CARRY THE LOAD, THE PRESSURE WILL RISE TO 110 PSI. THE MASTER PCB WILL THEN SIGNAL THE PUMP PCB TO TURN OFF THE LEAD COMPRESSOR. WHEN THE SYSTEM PRESSURE DROPS AGAIN BELOW THE LEAD SET-POINT, THE MASTER PCB WILL SEQUENCE THE LEAD ROLE TO THE NEXT COMPRESSOR AND IT WILL START. IF ANY LEAD COMPRESSOR RUNS FOR MORE THAN 17 MINUTES AND CANNOT REACH 110 PSI, THE MASTER PCB WILL TURN OFF THE COMPRESSOR THAT IS RUNNING AND SEQUENCE TO THE NEXT COMPRESSOR. IF DURING OPERATION THE PRESSURE FALLS BELOW 85 PSI, THE LAG COMPRESSOR WILL START AND A LAG ALARM WILL OCCUR.

PUMP PCB S1 POSITION:

POSITION (A) - AUTO (DEFAULT):
THE PUMP WILL OPERATE NORMALLY AS DESCRIBED ABOVE IN "AUTO OPERATION".
POSITION (X) - OFF:
THE PUMP IS DISABLED FROM RUNNING.
POSITION (O) - MANUAL:
THE PUMP WILL START AND STOP ON THE BACK UP PRESSURE SWITCH (BPS-1).

PCB FAULT:

IF A PUMP PCB ETHERNET FAULT OR A TRANSDUCER FAULT OCCURS, THE PUMP PCB WILL AUTOMATICALLY SWITCH TO MANUAL MODE. COMPRESSORS WILL START WHEN BPS-1 (BACKUP PRESSURE SWITCH) CLOSSES AND STOP WHEN IT OPENS. COMPRESSORS WILL NOT SEQUENCE IN THIS CONDITION AND CAN OPERATE UNTIL THE ETHERNET OR TRANSDUCER FAULT IS REPAIRED.

Revised: MOB	Date: 12/16/15	Drawn: JAH	Date: 01/31/11
		This drawing and the information contained thereon remain the property of BeaconMedics and may not be used for other than the purpose for which it is loaned without the expressed written permission from BeaconMedics Engineering.	
Description: DWG WIRING CONTROL HX SCROLL 15HP 208-460/3/50-60		Part Number: 4107 8526 87	
Sheet 1 of 4		Rev: 05 Scale: NTS	

Notes:

1. FIELD WIRING TO BE COPPER RATED FOR 75°C MINIMUM.

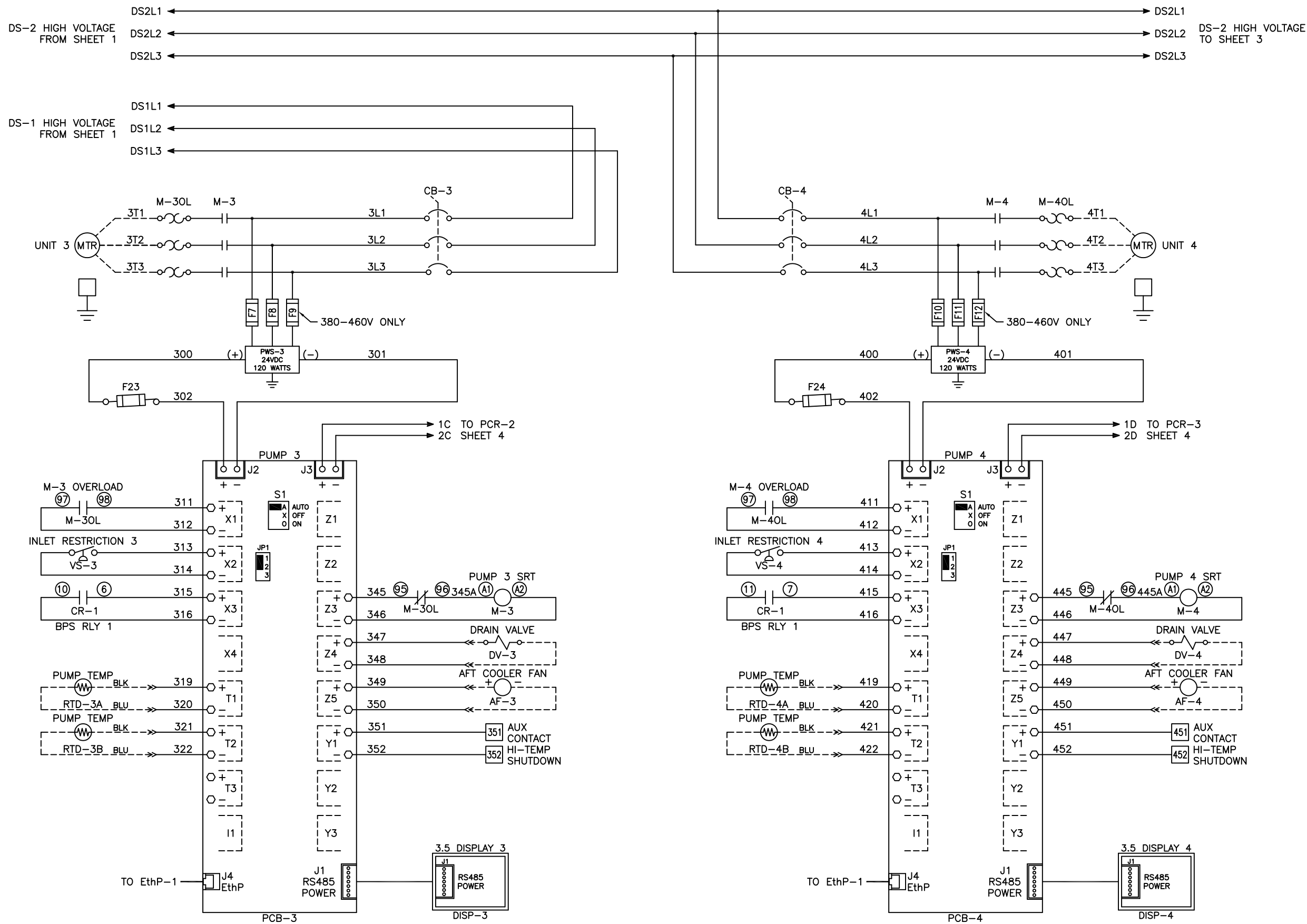

Revised: MDB	Date: 12/16/15	Drawn: JAH	Date: 01/31/11
		This drawing and the information contained thereon remain the property of BeaconMedes and may not be used for other than the purpose for which it is loaned without the expressed written permission from BeaconMedes Engineering.	
Description: DWG WIRING CONTROL HX SCROLL 15HP 208-460/3/50-60		Part Number: 4107 8526 87	
DN: HOP 151488		Rev: 05	
Sheet 2 of 4		DO NOT SCALE THIS DOCUMENT	

Notes:

1. FIELD WIRING TO BE COPPER RATED FOR 75°C MINIMUM.

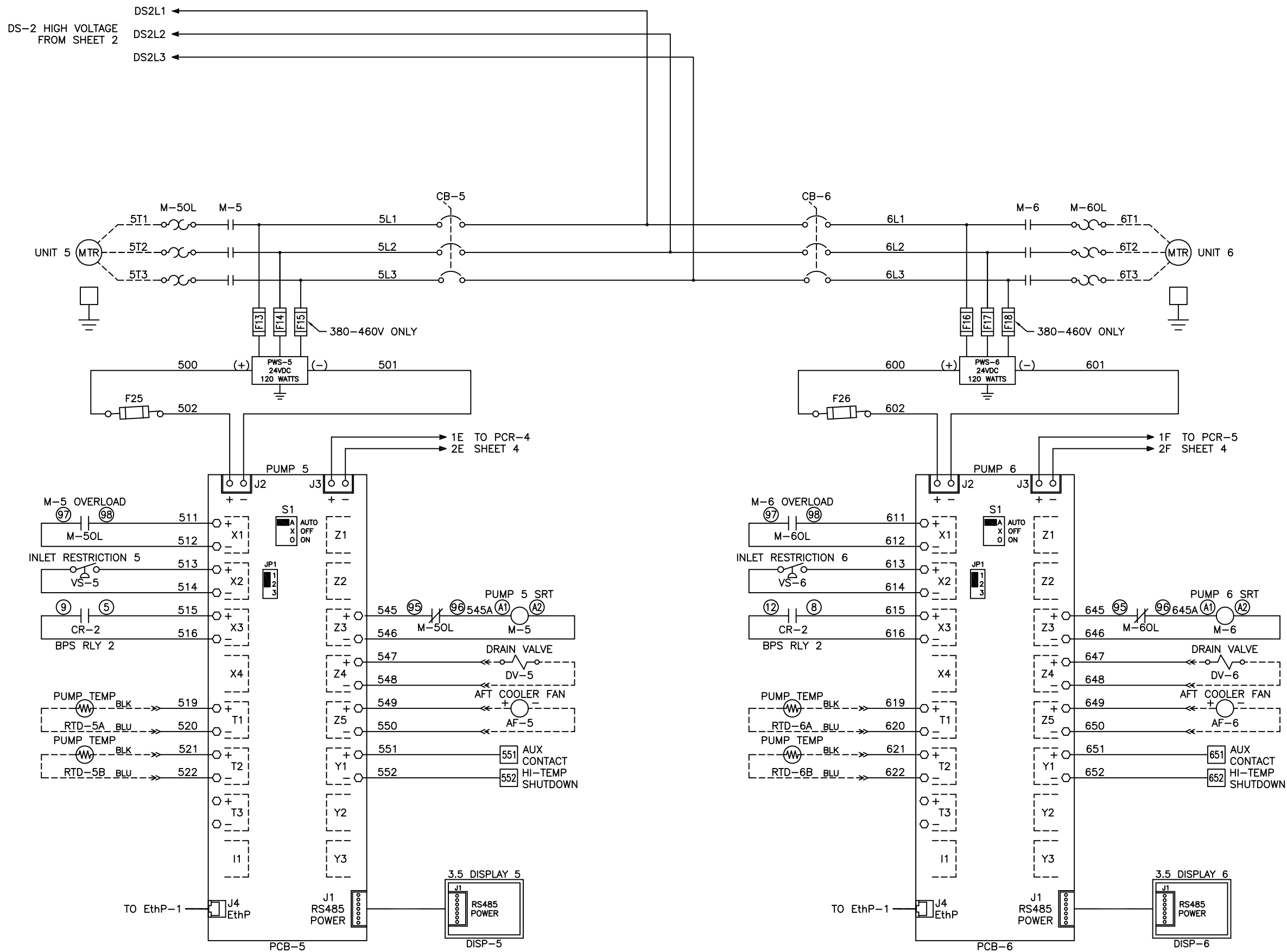

Revised: MDB	Date: 12/16/15	Drawn: JAH	Date: 01/31/11
		This drawing and the information contained thereon remain the property of BeaconMedics and may not be used for other than the purpose for which it is issued without the expressed written permission from BeaconMedics Engineering.	
Description: DWG WIRING CONTROL HX SCROLL 15HP 208-460/3/50-60		Part Number: 4107 8526 87	
DN: HOP 151488	Rev: 05	Scale: NTS	
Sheet 3 of 4	DO NOT SCALE THIS DOCUMENT		

Notes:

1. FIELD WIRING TO BE COPPER RATED FOR 75°C MINIMUM.

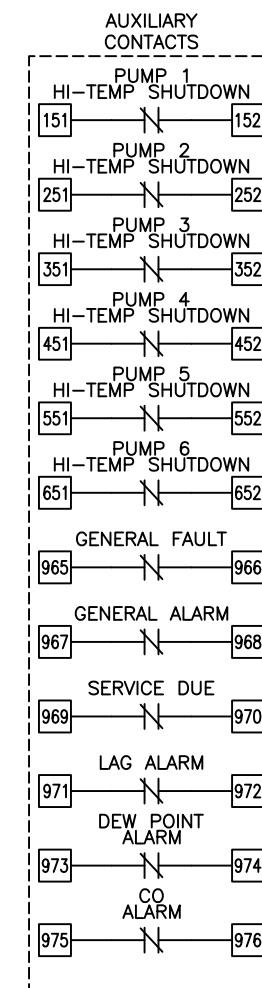
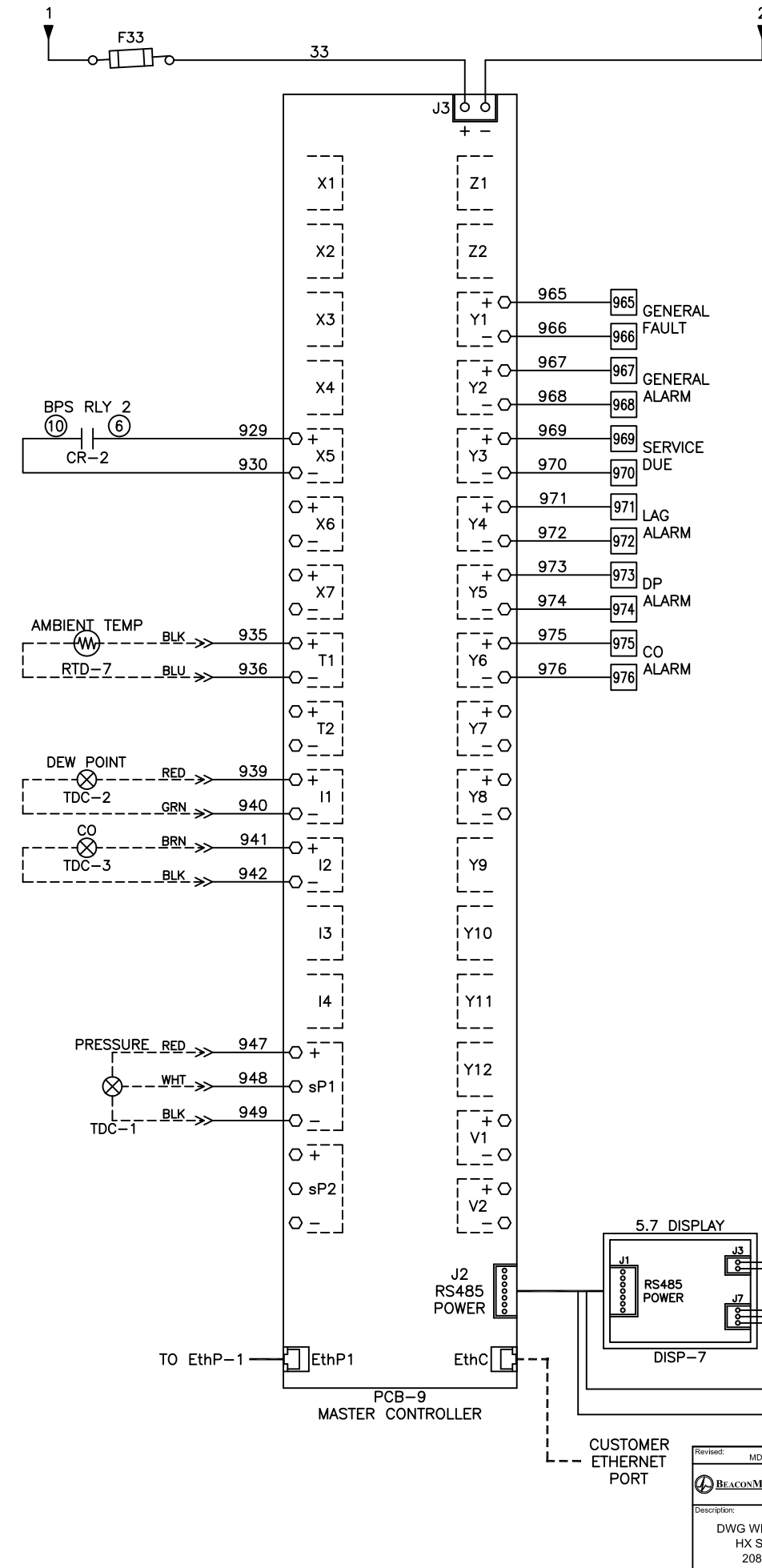
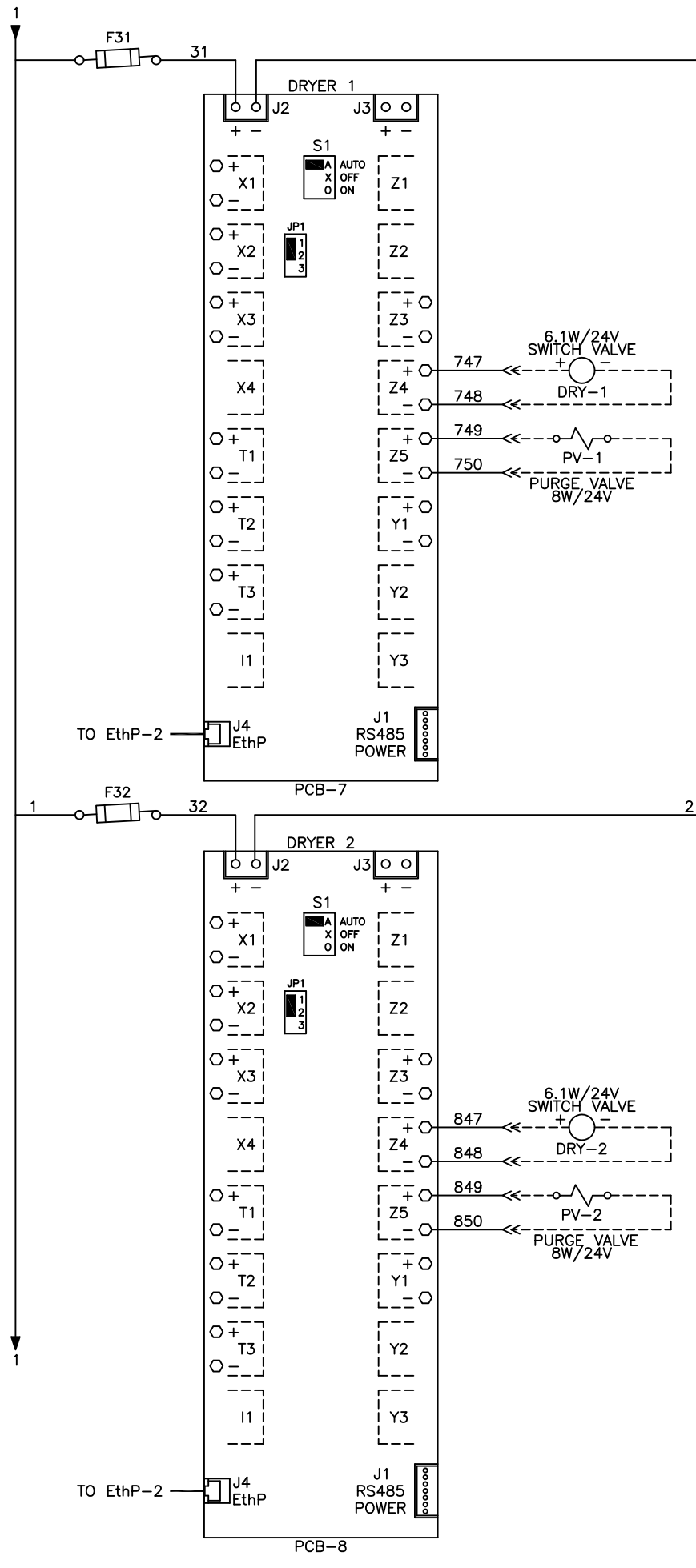
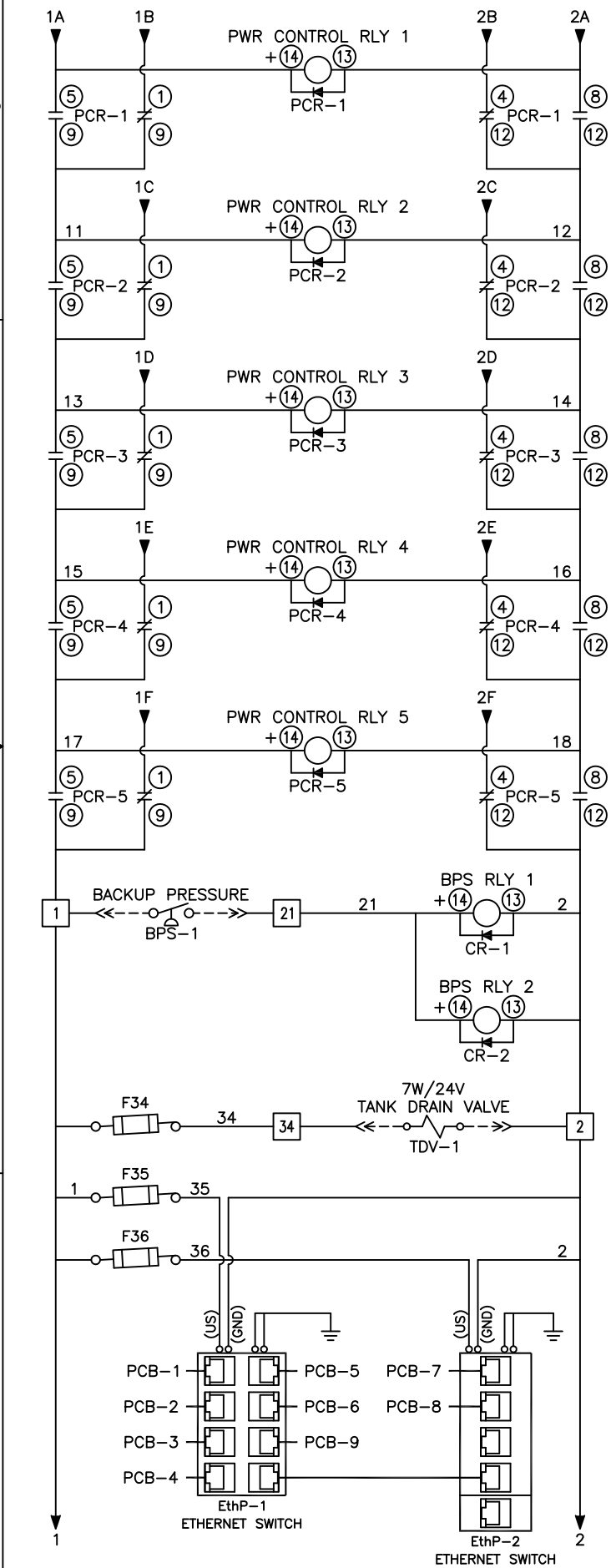

NOTE:
AUXILIARY CONTACTS
151-152, 251-252,
351-352, 451-452,
551-552, 651-652, &
965-976 ARE "CLASS 1
CONTROL CIRCUITS. USE
CLASS 1 CONDUCTORS."

AUX CONTACTS ARE RATED
0.7A_{dc}/0.7A_{ms} @ 24V
MAX. UNLESS OTHERWISE
NOTED.

AUX CONTACTS CLOSED
DURING NORMAL
OPERATION.

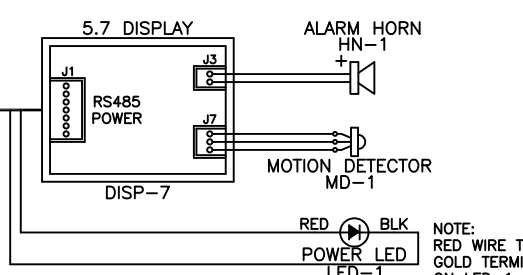

Revised: MDB	Date: 12/16/15	Drawn: JAH	Date: 01/31/11
Description: DWG WIRING CONTROL HX SCROLL 15HP 208-460/3/50-60		Part Number: 4107 8526 87	Scale: NTS
Sheet 4 of 4		Rev: 05	DO NOT SCALE THIS DOCUMENT