

Notes:

1. MAIN DISCONNECT PROVIDED BY OTHER.
2. FIELD WIRING TO BE COPPER RATED FOR 75°C MINIMUM.
3. - - - - INDICATES FIELD WIRING OUTSIDE OF CABINET.
4. RTD-1B & RTD-2B ON 10-15HP ONLY.
5. AUXILIARY CONTACT LIST ON SHEET 3.
6. THE AMPACITY OF CONDUCTORS SUPPLYING THE CONTROL PANEL TO BE ROUNDED UP TO THE NEXT SIZE LARGER STANDARD WIRE GAUGE.
7. MOP VALUES TO BE ROUNDED DOWN TO THE NEAREST STANDARD RATING OF THE OVERCURRENT PROTECTION DEVICE.
8. SHORT CIRCUIT CURRENT RATING (SCCR): 5 kA

208 - 460 V  
3 Ø  
50 / 60 Hz  
SCCR: 5 kA

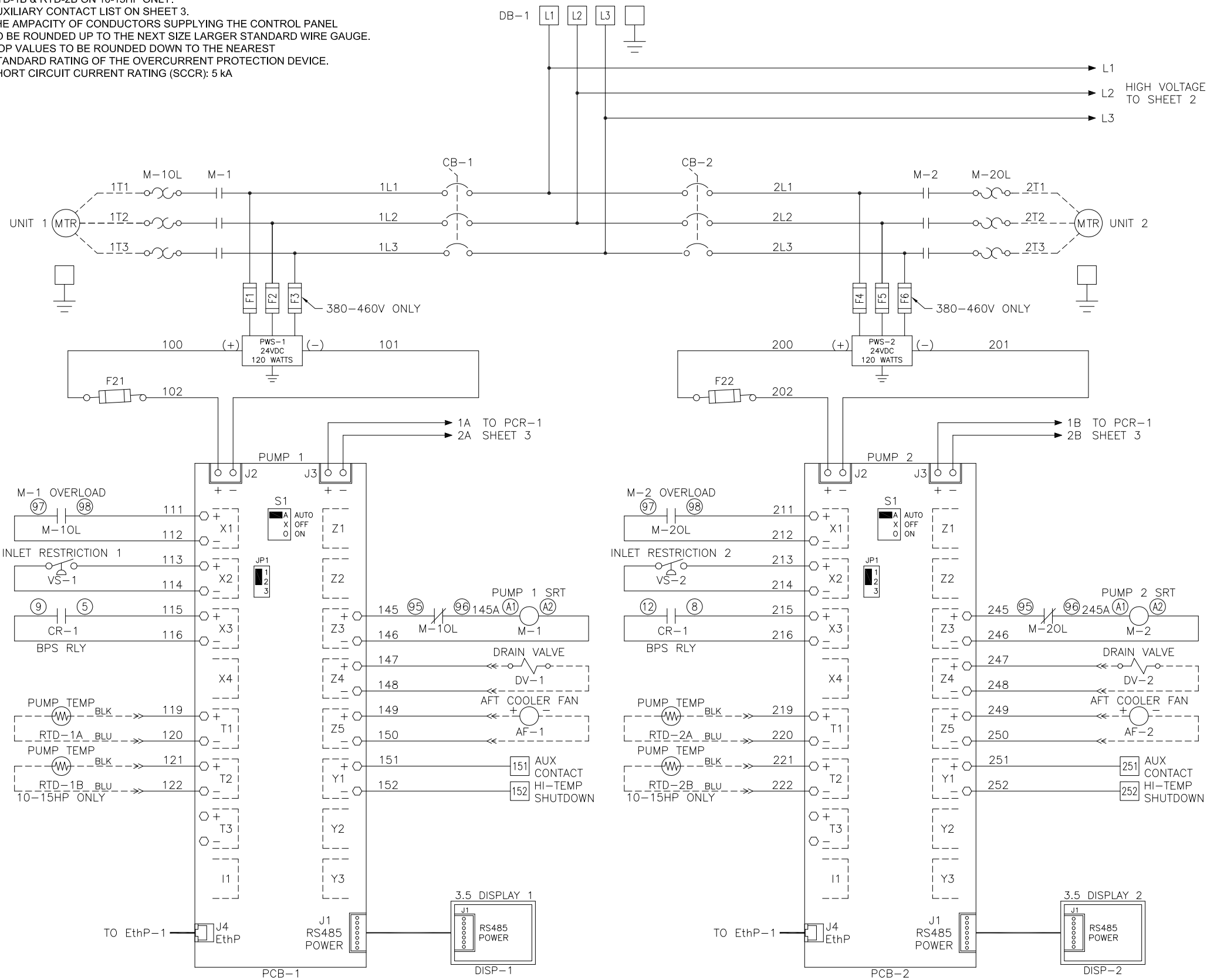

MINIMUM CIRCUIT AMPACITY (MCA)

SYSTEM HP	208 V	230 V	380/415 V	460 V
5 HP	56.9 AMPS	51.8 AMPS	33.4 AMPS	26.2 AMPS
7.5 HP	81.3 AMPS	73.9 AMPS	47.4 AMPS	37.3 AMPS
10 HP	102.7 AMPS	93.4 AMPS	60.4 AMPS	47.0 AMPS
15 HP	152.8 AMPS	138.9 AMPS	89.6 AMPS	69.8 AMPS

MAXIMUM OVERCURRENT PROTECTION (MOP)

SYSTEM HP	208 V	230 V	380/415 V	460 V
5 HP	71.0 AMPS	64.6 AMPS	41.2 AMPS	32.3 AMPS
7.5 HP	102.9 AMPS	93.5 AMPS	59.5 AMPS	46.8 AMPS
10 HP	130.9 AMPS	119.0 AMPS	76.5 AMPS	59.5 AMPS
15 HP	196.4 AMPS	178.5 AMPS	114.8 AMPS	89.3 AMPS

TRIPLEX SYSTEM FULL LOAD AMPERES

SYSTEM HP	208 V	230 V	380V/50Hz	415V/50Hz	460 V
5 HP	40.5 AMPS	37.9 AMPS	26.1 AMPS	16.5 AMPS	19.3 AMPS
7.5 HP	56.1 AMPS	53.5 AMPS	29.7 AMPS	30.6 AMPS	27.1 AMPS
10 HP	78.3 AMPS	73.9 AMPS	41.7 AMPS	40.2 AMPS	37.3 AMPS
15 HP	110.1 AMPS	106.9 AMPS	63.0 AMPS	60.9 AMPS	53.8 AMPS

INDIVIDUAL FULL LOAD AMPERES

SYSTEM HP	208 V	230 V	380V/50Hz	415V/50Hz	460 V
5 HP	12.8 AMPS	12.0 AMPS	8.2 AMPS	5.0 AMPS	6.0 AMPS
7.5 HP	18.0 AMPS	17.2 AMPS	9.4 AMPS	9.7 AMPS	8.6 AMPS
10 HP	25.6 AMPS	24.0 AMPS	13.4 AMPS	12.9 AMPS	12.0 AMPS
15 HP	36.0 AMPS	35.0 AMPS	20.5 AMPS	19.8 AMPS	17.5 AMPS

FUSE SELECTION CHART (MAX FUSE SIZES SHOWN)

FUSES	208 V	230 V	380 V	415 V	460 V
F1/F2/F4/ F5/F7/F8	6.0 AMPS	6.0 AMPS	6.0 AMPS	6.0 AMPS	6.0 AMPS
F3/F6/F9	---	---	6.0 AMPS	6.0 AMPS	6.0 AMPS
F21-F23	4.0 AMPS	4.0 AMPS	4.0 AMPS	4.0 AMPS	4.0 AMPS
F31/F32/ F33/F34	1.0 AMP	1.0 AMP	1.0 AMP	1.0 AMP	1.0 AMP
F35	0.5 AMP	0.5 AMP	0.5 AMP	0.5 AMP	0.5 AMP

F1-F9 ARE LITTELFUSE KLDR 600V TYPE  
F21-F23/F31-F35 ARE LITTELFUSE 2AG 250V TYPE

DEFAULT PUMP PSI SETTINGS

PUMP SEQUENCE	PSI
LEAD CUT-OFF	110
LAG CUT-ON	85

BACKUP PRESSURE SWT SETTINGS

BPS-1 CUT-OFF	PSI
BPS-1 CUT-ON	80

AUTO OPERATION:

DURING NORMAL OPERATION, THE MASTER PCB WILL SIGNAL THE LEAD COMPRESSOR TO START WHEN THE PRESSURE FALLS BELOW THE SET-POINT FOR THE LEAD PUMP. IF ONE PUMP CAN CARRY THE LOAD, THE PRESSURE WILL RISE TO 110 PSI. THE MASTER PCB WILL THEN SIGNAL THE PUMP PCB TO TURN OFF THE LEAD COMPRESSOR. WHEN THE SYSTEM PRESSURE DROPS AGAIN BELOW THE LEAD SET-POINT, THE MASTER PCB WILL SEQUENCE THE LEAD ROLE TO THE NEXT COMPRESSOR AND IT WILL START. IF ANY LEAD COMPRESSOR RUNS FOR MORE THAN 17 MINUTES AND CANNOT REACH 110 PSI, THE MASTER PCB WILL TURN OFF THE COMPRESSOR THAT IS RUNNING AND SEQUENCE TO THE NEXT COMPRESSOR. IF DURING OPERATION THE PRESSURE FALLS BELOW 85 PSI, THE LAG COMPRESSOR WILL START AND A LAG ALARM WILL OCCUR.

PUMP PCB S1 POSITION:

POSITION (A) - AUTO (DEFAULT):  
THE PUMP WILL OPERATE NORMALLY AS DESCRIBED ABOVE IN "AUTO OPERATION".  
POSITION (X) - OFF:  
THE PUMP IS DISABLED FROM RUNNING.  
POSITION (O) - MANUAL:  
THE PUMP WILL START AND STOP ON THE BACK UP PRESSURE SWITCH (BPS-1).

PCB FAULT:

IF A PUMP PCB ETHERNET FAULT OR A TRANSDUCER FAULT OCCURS, THE PUMP PCB WILL AUTOMATICALLY SWITCH TO MANUAL MODE. COMPRESSORS WILL START WHEN BPS-1 (BACKUP PRESSURE SWITCH) CLOSSES AND STOP WHEN IT OPENS. COMPRESSORS WILL NOT SEQUENCE IN THIS CONDITION AND CAN OPERATE UNTIL THE ETHERNET OR TRANSDUCER FAULT IS REPAIRED.

PUMP/DRYER PCB JUMPER/SWT SETTINGS

JPR/SWT	POSITION
JP1	1-2
S1	A (AUTO)

Revised: DAG	Date: 06/16/16	Drawn: JAH	Date: 01/24/11
		Scale: NTS <b>D</b>	
Description: DWG WIRING CONTROL TX SCROLL 5-15HP 208-460/3/50-60		Part Number: 4107 8526 81	
DN: HOP 160683 00		Rev: 06	
Sheet 1 of 3		DO NOT SCALE THIS DOCUMENT	

Notes:

1. FIELD WIRING TO BE COPPER RATED FOR 75°C MINIMUM.
2. RTD-3B ON 10-15HP ONLY.

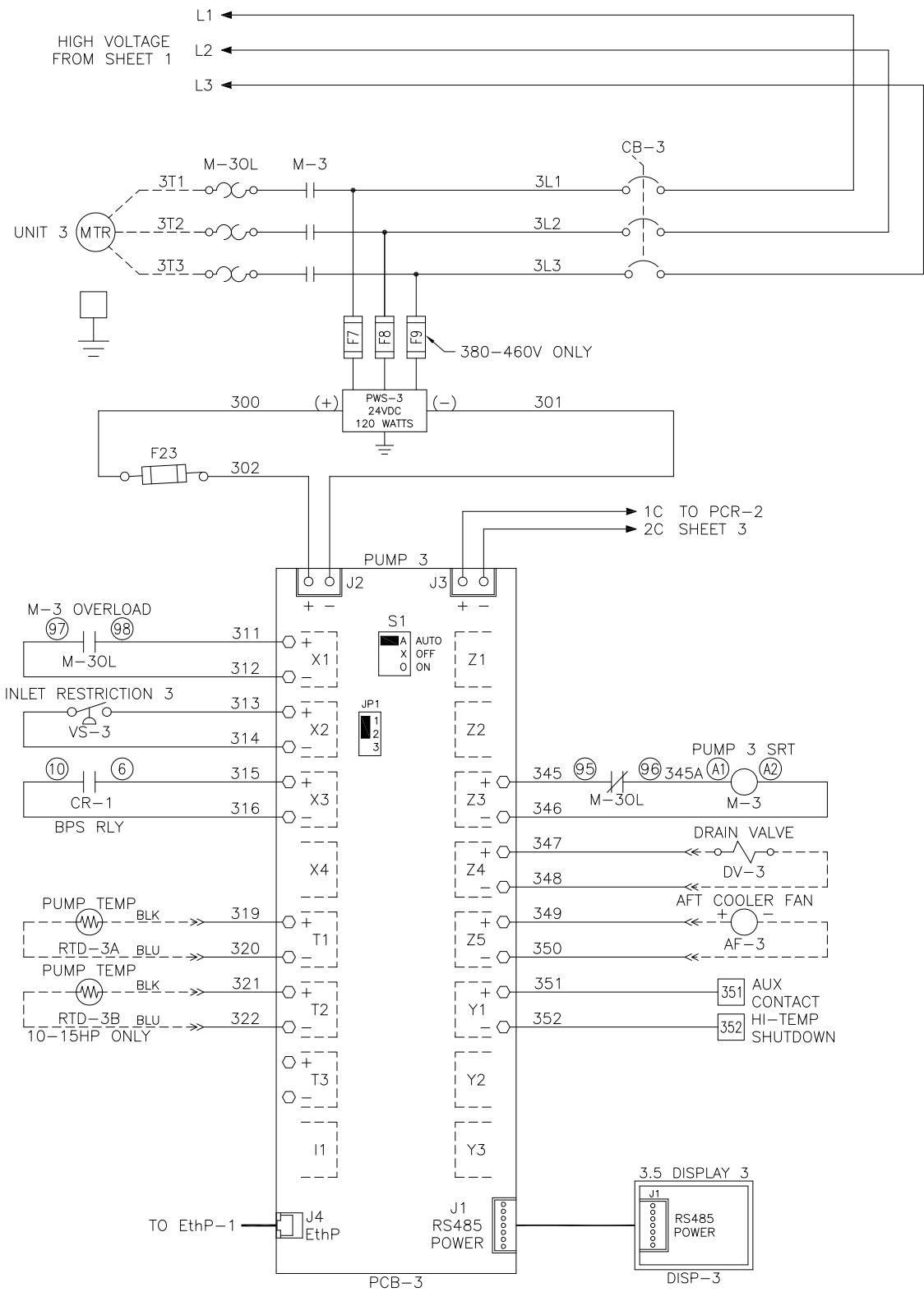

PUMP/DRYER PCB  
JUMPER/SWT SETTINGS

JPR/SWT	POSITION
JP1	1-2
S1	A (AUTO)

Revised: DAG	Date: 06/16/16	Drawn: JAH	Date: 01/24/11
			Scale: NTS
Description: DWG WIRING CONTROL TX SCROLL 5-15HP 208-460/3/50-60			Part Number: 4107 8526 81
DN: HOP 160683 00		Rev: 06	
Sheet 2 of 3		DO NOT SCALE THIS DOCUMENT	

Notes:  
 1. FIELD WIRING TO BE COPPER RATED FOR 75°C MINIMUM.

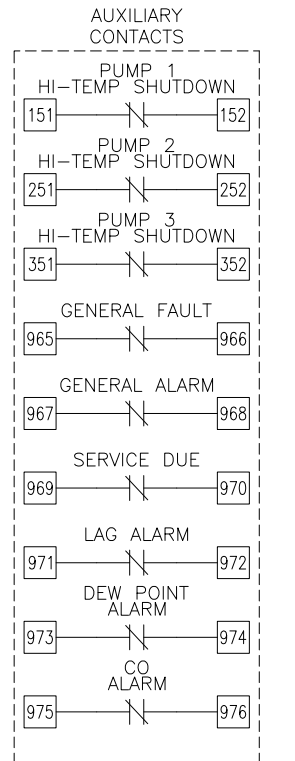
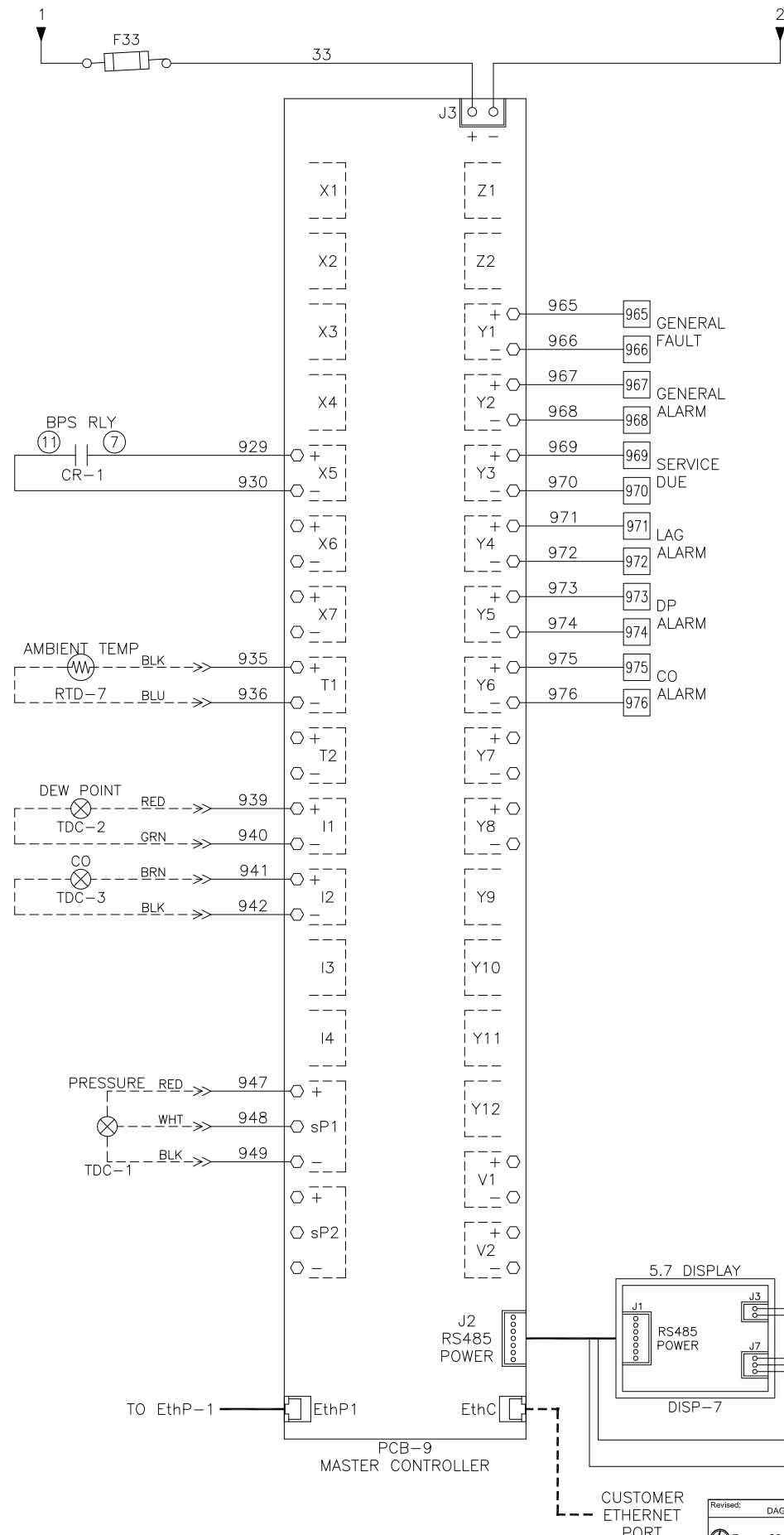
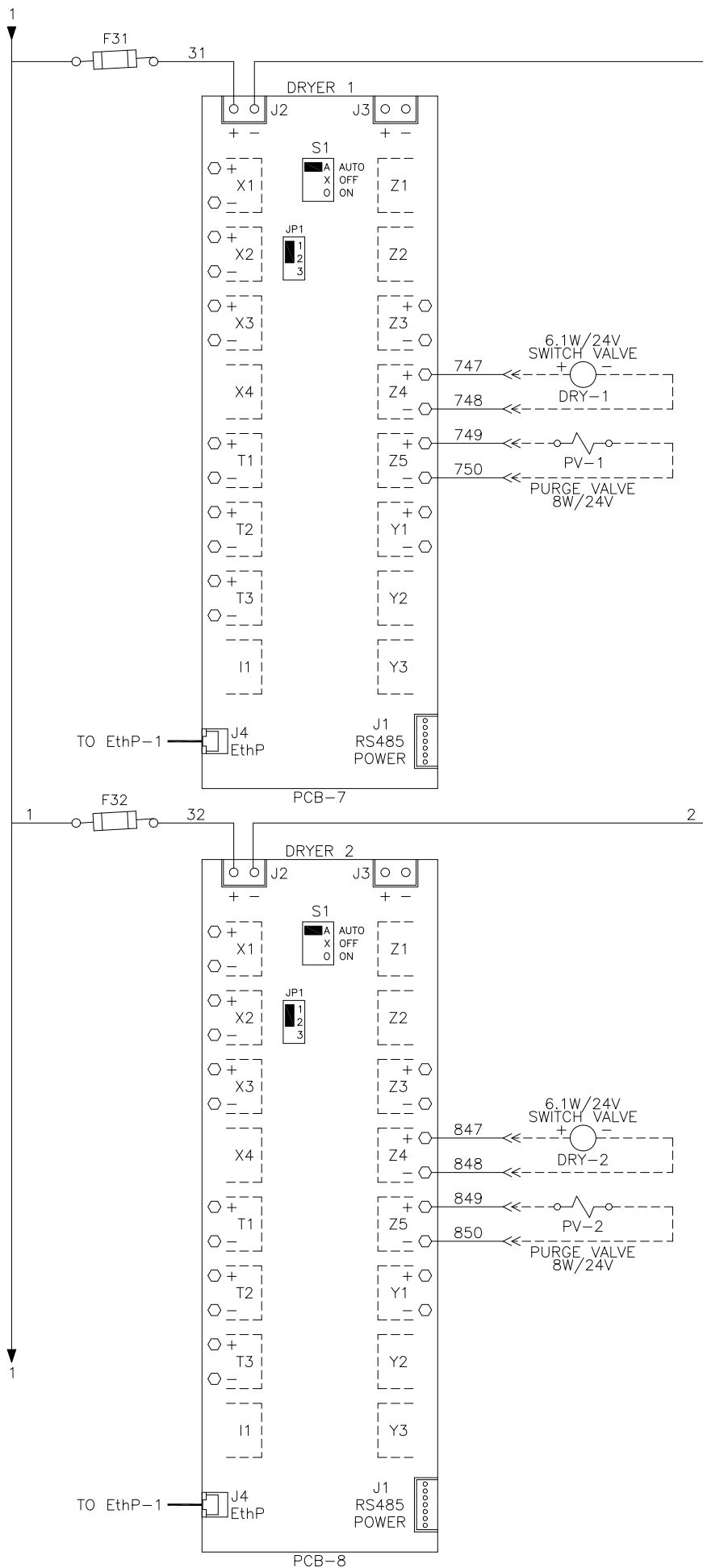
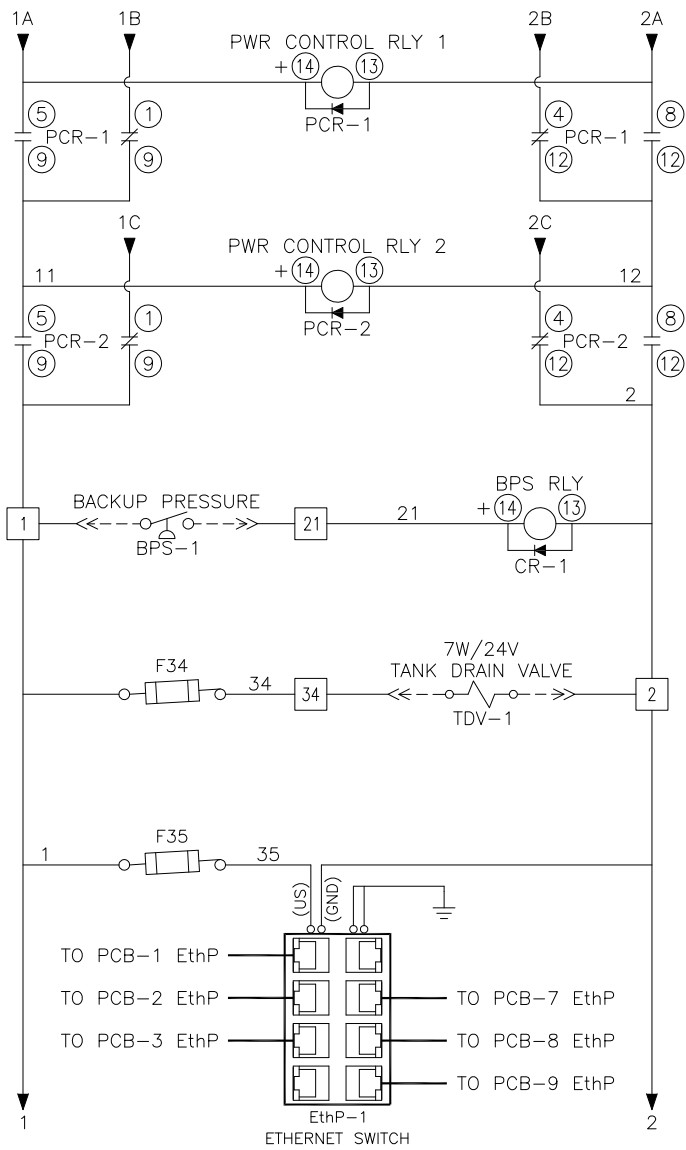

NOTE:  
 AUXILIARY CONTACTS 151-152, 251-252, 351-352, & 965-976 ARE "CLASS 1 CONTROL CIRCUITS. USE CLASS 1 CONDUCTORS."  
 AUX CONTACTS ARE RATED 0.7Adc/0.7Arms @ 24V MAX. UNLESS OTHERWISE NOTED.  
 AUX CONTACTS CLOSED DURING NORMAL OPERATION.

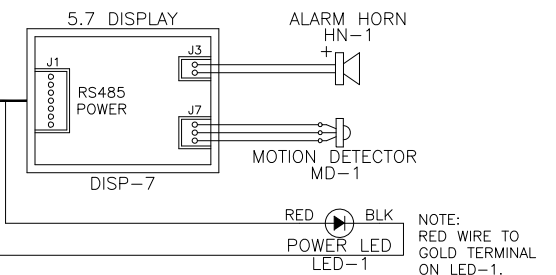

Revised: DAG	Date: 06/16/16	Drawn: JAH	Date: 01/24/11
		This drawing and the information contained herein remain the property of BeaconMedics and may not be used for other than the purpose for which it is issued without the expressed written permission from BeaconMedics Engineering.	
Description: DWG WIRING CONTROL TX SCROLL 5-15HP 208-460/3/50-60		Part Number: 4107 8526 81	
DN: HOP 160683 00		Rev: 06	
Sheet 3 of 3		DO NOT SCALE THIS DOCUMENT	