

INDEX	
SHEET	DESCRIPTION
01	INDEX
02	POWER CIRCUIT MAIN MOTOR
03	POWER CIRCUIT DRYER
04	SUPPLY CONTROL CIRCUIT
05	CONTROL CIRCUIT
06	REGULATOR MkV
07	EXPENTION MODULE IO2
08	INPUT CONNECTIONS 2X27
09	INPUT CONNECTIONS 2X28
10	INPUT CONNECTIONS 3X33
11	INPUT CONNECTIONS 3X34
12	INPUT CONNECTIONS 3X35
13	OPTIONAL CONTACTS
14	LEGEND
15	LEGEND
16	NOTES

INSTALLED	OPTIONAL COMPONENTS
	Full feature (dryer A1) K11 : dryer contactor TT90 : LAT sensor
	B1 : electronic water drain
	S10 : Main Switch
	Alarm horn
	Elektronicon connectivity Functions
	Integrated ES systems
	M7 cabinet Fan

**MAIN POWER SUPPLY**

VOLTAGE : .....	V
FREQ : .....	Hz 3 PH

**MAX FUSE [A] CSA/UL ONLY**

CSA : HRC Form II	
.....	A
UL : Class K5	
.....	A

**SETTING**

Q21	... A
Q22	... A
Q23	... A
Q24	... A

**MOTORDATA**

M1	kW	HP	SF :
M2	kW	HP	SF :
M3	kW	HP	SF :
M4	kW	HP	SF :

**DRYERDATA**

A1	kW	HP	
----	----	----	--

All materials supplied are in compliance with the requirements of the List of Prohibited Substance

Name	DIAGRAM SERVICE	LES 22-30	Secrecy Class	
Material	NOT APPLICABLE	Fixed speed, DOL starter	1102 K/ 2	
Treatment	Not Applicable		ACD	
Scale	1:1	Family	A3	Compare
Drawn by	AIR15507	Blank nr.		Replaces
Version Drwg	04	Blank wt.	0 Kg	Fini wt.
			0 Kg	Designation
STATUS	Approved	Des checked.	Prod checked.	Approved.
			Date	2012-03-22
				8920 4970 06
				Sheet 01 (16 )
				Drawing owner: All

04		Update sheet 4 T1, F1,F2 not inside T1	2014-08-08	04/15507					
Note	Position	Modified from	Date	Intr./Appd.	Parent 3D Model	Ed Version 3D			

Confidential

This document is property of the company and its use is restricted to the person or company who has provided it. It is not to be distributed, copied, used for manufacturing or communicated to any other person or company.

POWER CIRCUIT MAIN MOTOR

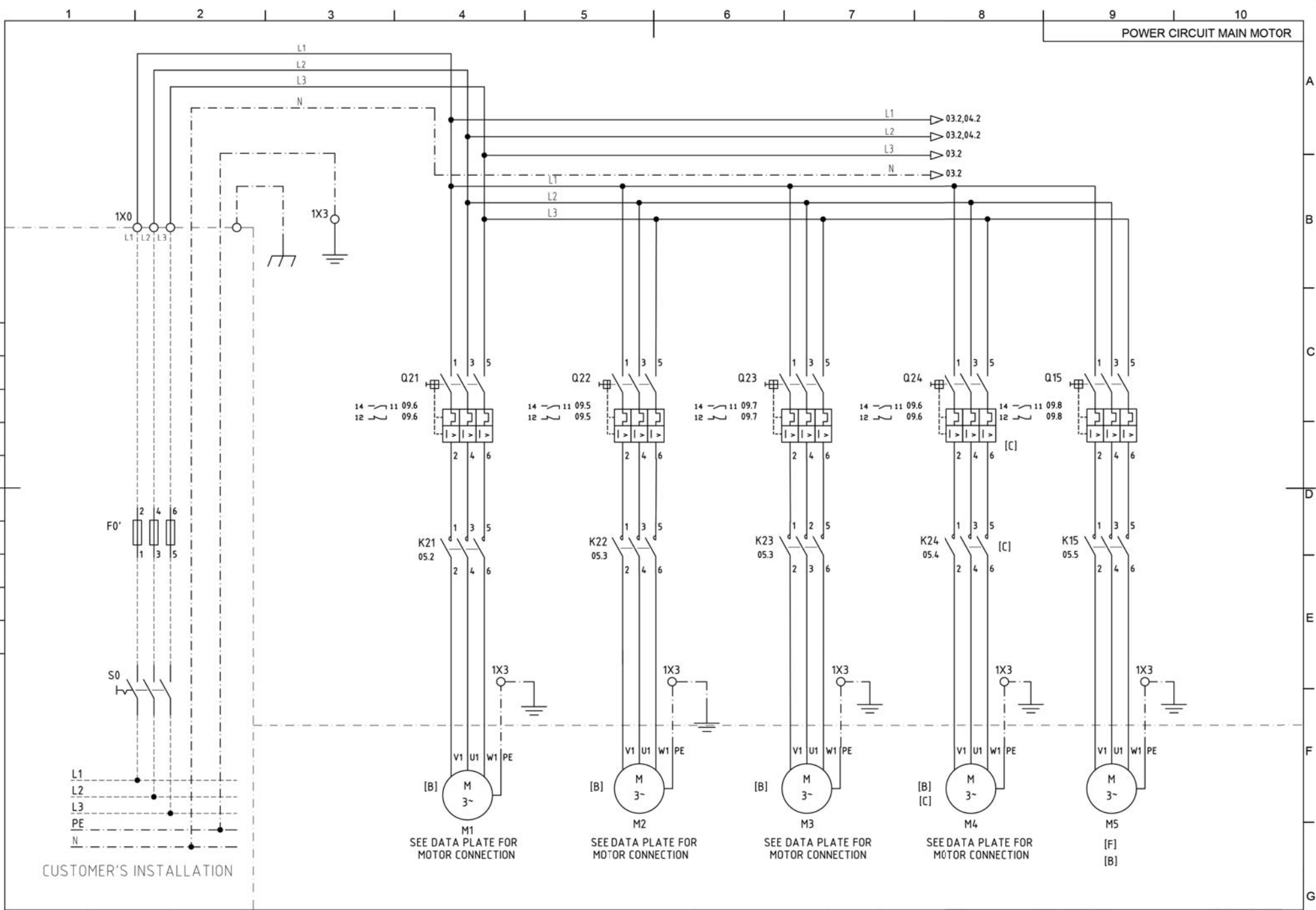

CUSTOMER'S INSTALLATION

SEE DATA PLATE FOR MOTOR CONNECTION

SEE DATA PLATE FOR MOTOR CONNECTION

SEE DATA PLATE FOR MOTOR CONNECTION

SEE DATA PLATE FOR MOTOR CONNECTION

SEE DATA PLATE FOR MOTOR CONNECTION

ACD	Name	DIAGRAM SERVICE
Drawing owner All		Fixed speed, DOL starter

LES 22-30

STATUS	Ed.	Date	Prev. Page 01	Next Page 03	A3
Approved	04	2014-08-08	Drawn by AIR15507	Date 2012-03-22	

Designation	Sheet 02 (16)
9820 4970 06	

This document is the property of and shall not be used without the permission of the manufacturer. It is intended for manufacturing or communication to any other person or company.

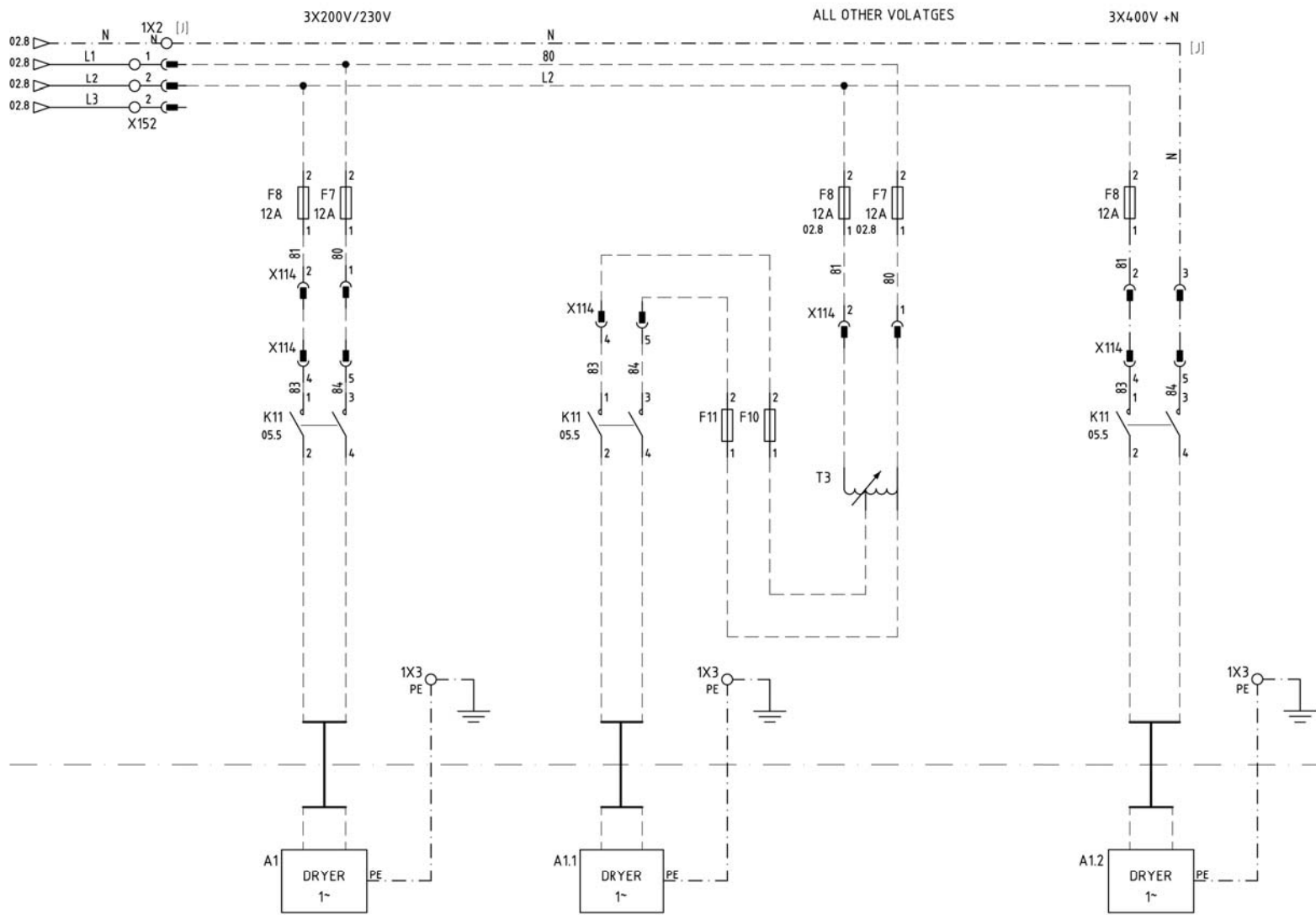

This document is the property of and shall not be used for purposes not intended without the written permission of the manufacturer or communicated to any other person or company.

ACD	Name	DIAGRAM SERVICE	LES 22-30	STATUS	Ed.	Date	Prev. Page 02	Next Page 04	A3	Designation	Sheet 03 (16)
	Drawing owner	Fixed speed, DOL starter		Approved	04	2014-08-08	Drawn by	AIR15507	Date	2012-03-22	9820 4970 06

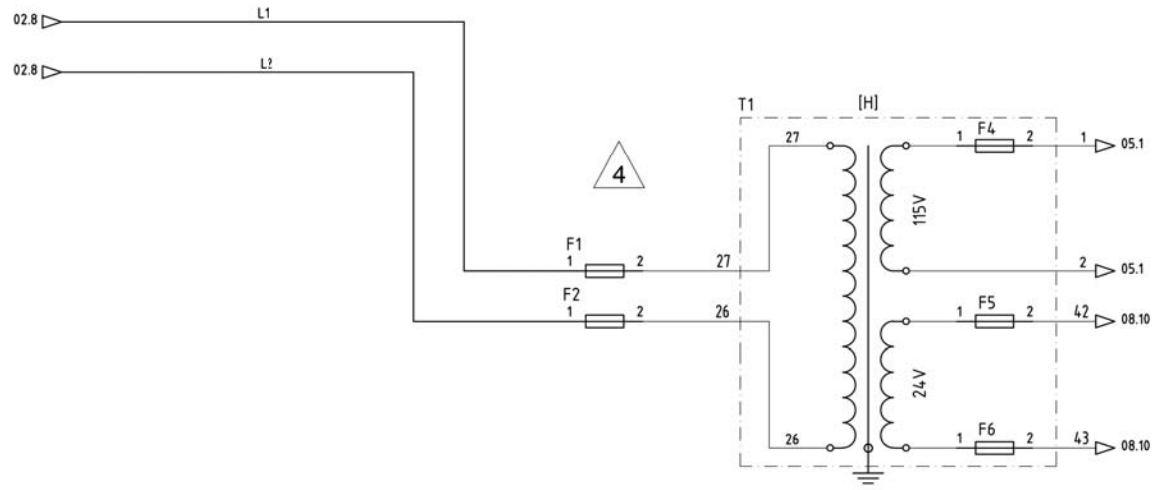

This document is the property of and shall not be used for purposes not intended without the express written permission of the manufacturer. It is to be used for manufacturing or communication to any other person or company.

ACD	Name	DIAGRAM SERVICE	LES 22-30	STATUS	Ed.	Date	Prev. Page 03	Next Page 05	A3	Designation	Sheet 04 (16)
	Drawing owner	Fixed speed, DOL starter		Approved	04	2014-08-08	Drawn by AIR15507	Date 2012-03-22	9820 4970 06		

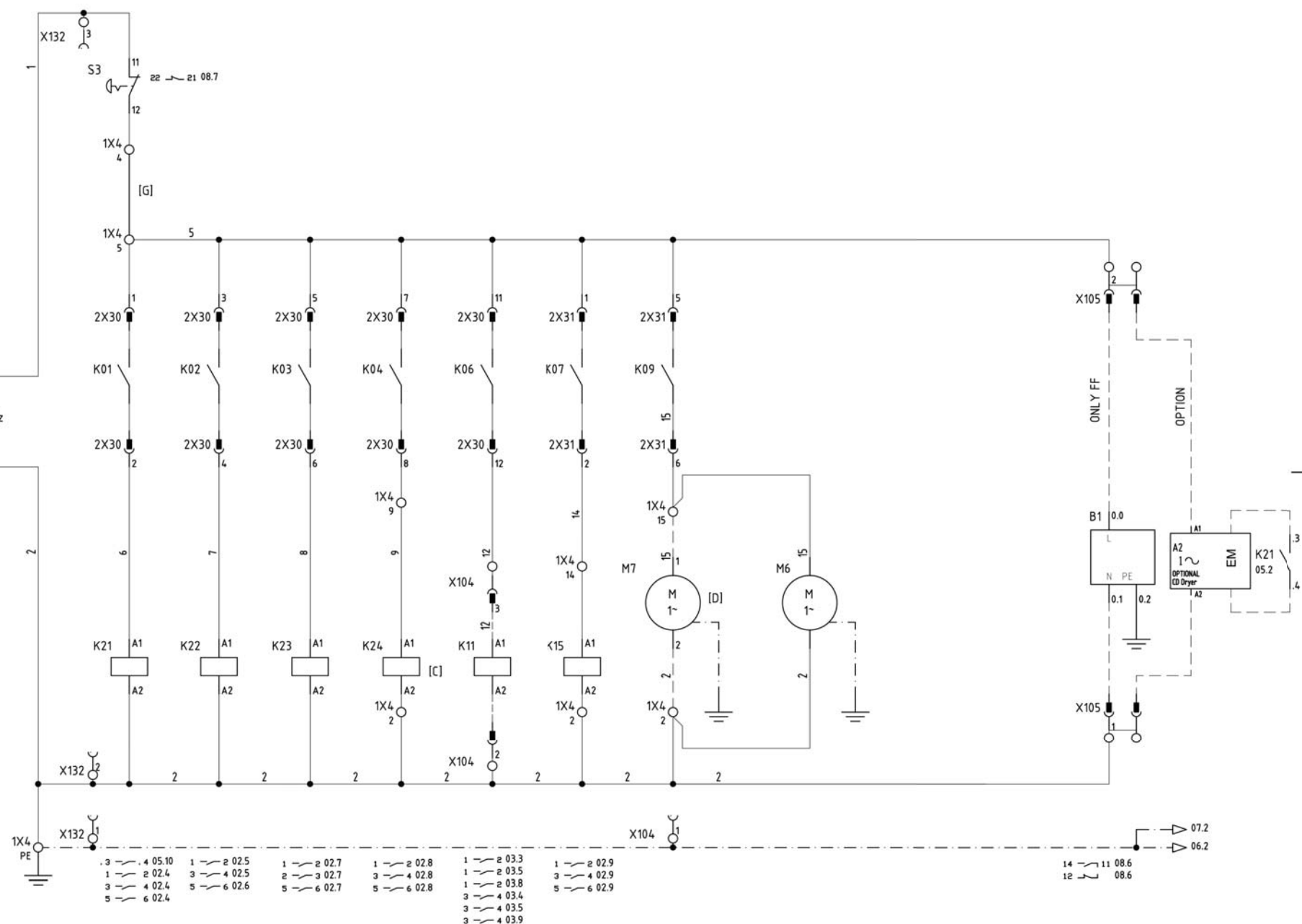

This document is the property of and shall not be used without the permission of the client. It is intended for manufacturing or communication to any other person or company.

ACD	Name	DIAGRAM SERVICE
Drawing owner		Fixed speed, DOL starter
All		

LES 22-30

STATUS	Ed.	Date	Prev. Page 04	Next Page 06	A3
Approved	04	2014-08-08	Drawn by AIR15507	Date 2012-03-22	

Designation	Sheet 05 (16)
<b>9820 4970 06</b>	

REGULATOR

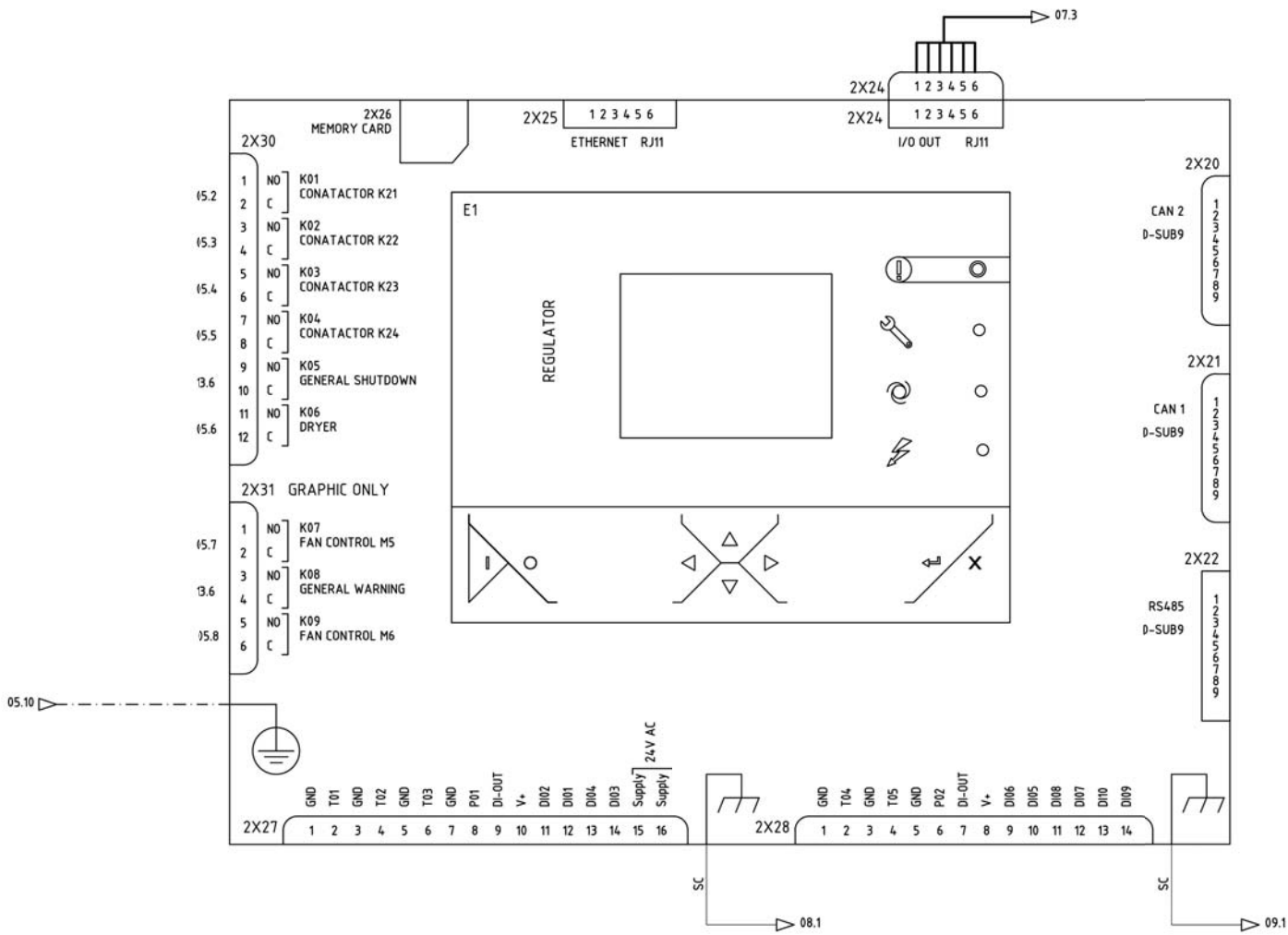

This document is the property of and shall not be used without the permission of the client. It is intended for manufacturing or communication to any other person or company.

ACD	Name	DIAGRAM SERVICE	LES 22-30	STATUS	Ed.	Date	Prev. Page 05	Next Page 07	A3	Designation	Sheet 06 (16)
	Drawing owner	Fixed speed, DOL starter		Approved	04	2014-08-08	Drawn by AIR15507	Date 2012-03-22		9820 4970 06	

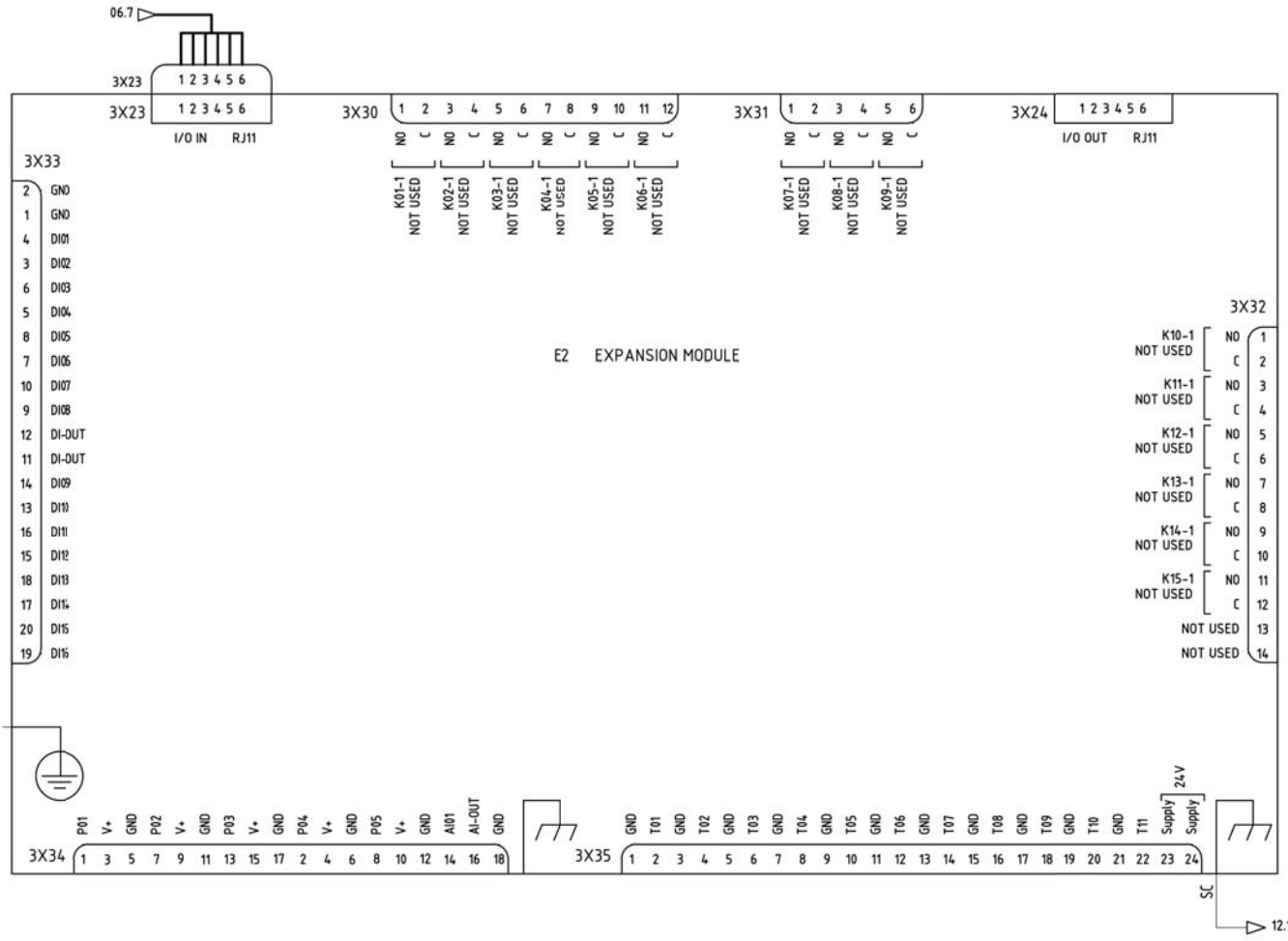

This document is the property of and shall not be used for permission to be offered, copied, used for manufacturing or communication to any other person or company.

ACD	Name	DIAGRAM SERVICE
Drawing owner		Fixed speed, DOL starter
All		

LES 22-30

STATUS	Ed.	Date	Prev. Page 06	Next Page 08	A3
Approved	04	2014-08-08	Drawn by AIR15507	Date 2012-03-22	

Designation	Sheet 07 (16)
<b>9820 4970 06</b>	

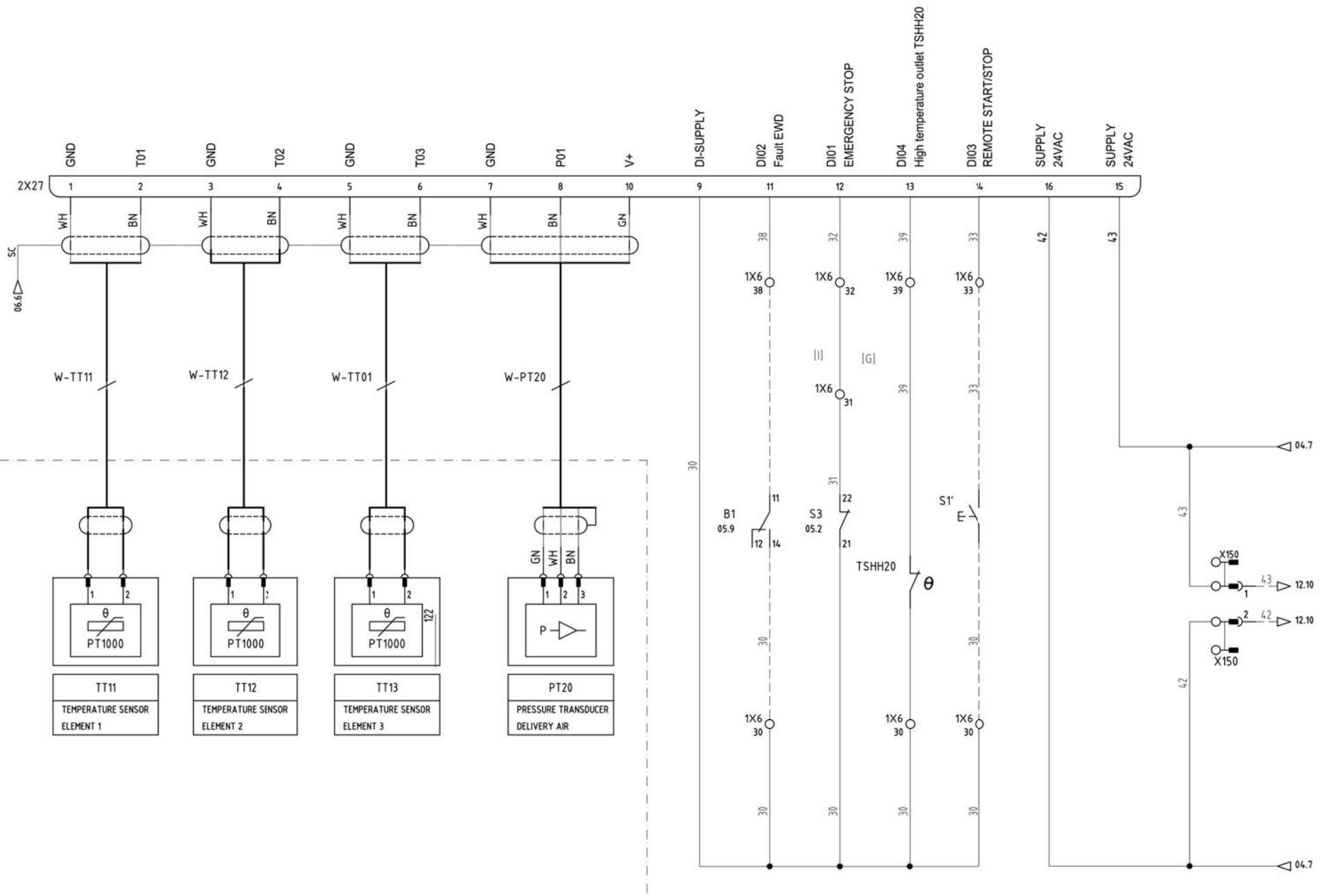

This document is the property of and shall not be used for purposes not intended without the express written permission of the manufacturer. All rights reserved. Copying, distributing, or communicating to any other person or company is prohibited.

ACD	Name	DIAGRAM SERVICE
Drawing owner All		Fixed speed, DOL starter

LES 22-30

STATUS	Ed.	Date	Prev. Page 07	Next Page 09	A3
Approved	04	2014-08-08	Drawn by AIR15507	Date 2012-03-22	

Designation **9820 4970 06** Sheet 08 (16)



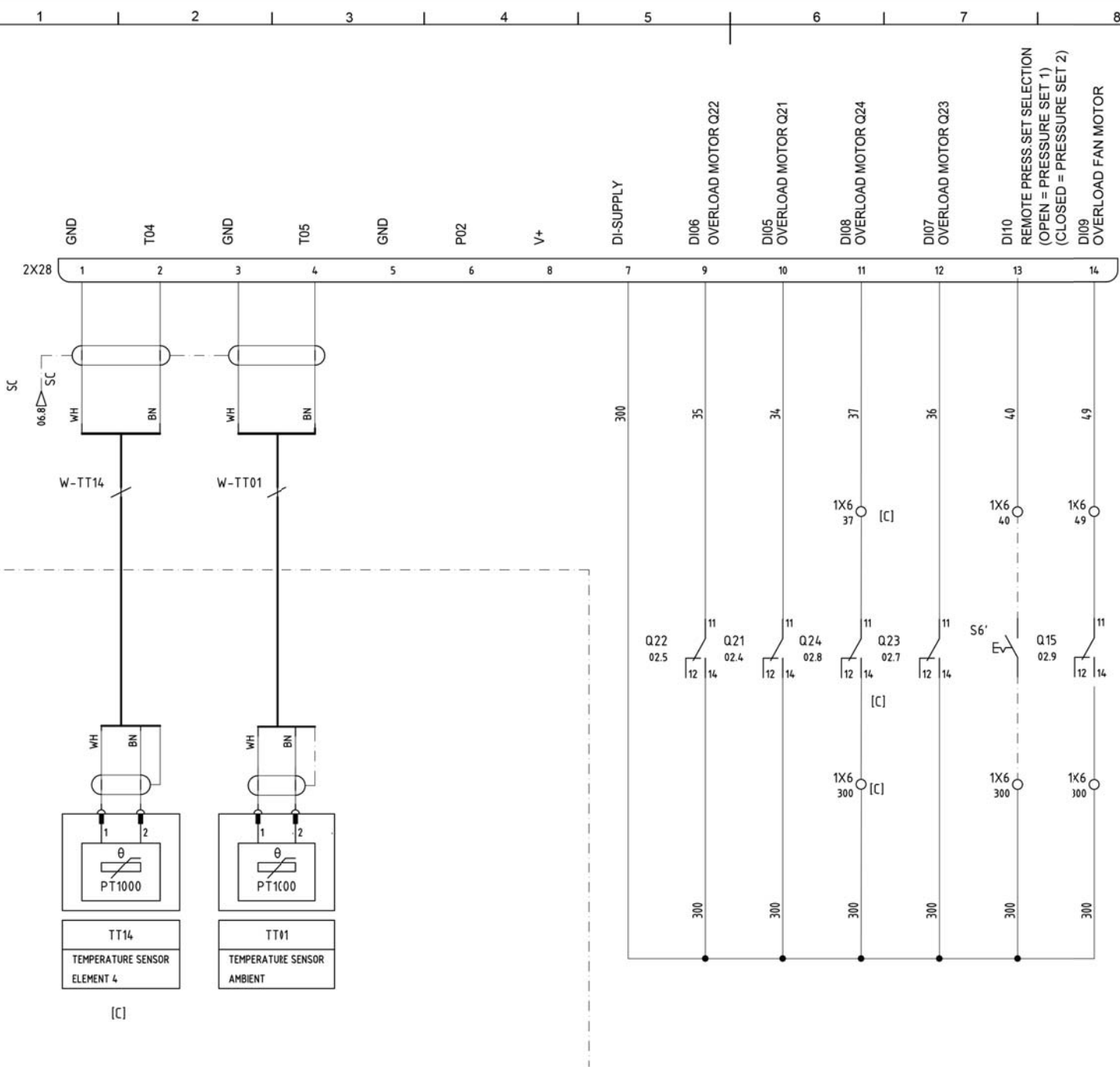

This document is the property of and shall not be used without the permission for release or copied, used for manufacturing or communicated to any other person or company.

ACD	Name	DIAGRAM SERVICE
Drawing owner All		Fixed speed, DOL starter

LES 22-30

STATUS	Ed.	Date	Prev. Page 08	Next Page 10	A3
Approved	04	2014-08-08	Drawn by AIR15507	Date 2012-03-22	

Designation	Sheet 09 (16)
<b>9820 4970 06</b>	



This document is for internal use only and shall not be used for permission to be offered, copied, used for manufacturing or communicated to any other person or company.

ACD	Name	DIAGRAM SERVICE	LES 22-30	STATUS	Ed.	Date	Prev. Page 09	Next Page 11	A3	Designation	Sheet 10 (16)
	Drawing owner	Fixed speed, DOL starter		Approved	04	2014-08-08	Drawn by AIR15507	Date 2012-03-22		9820 4970 06	

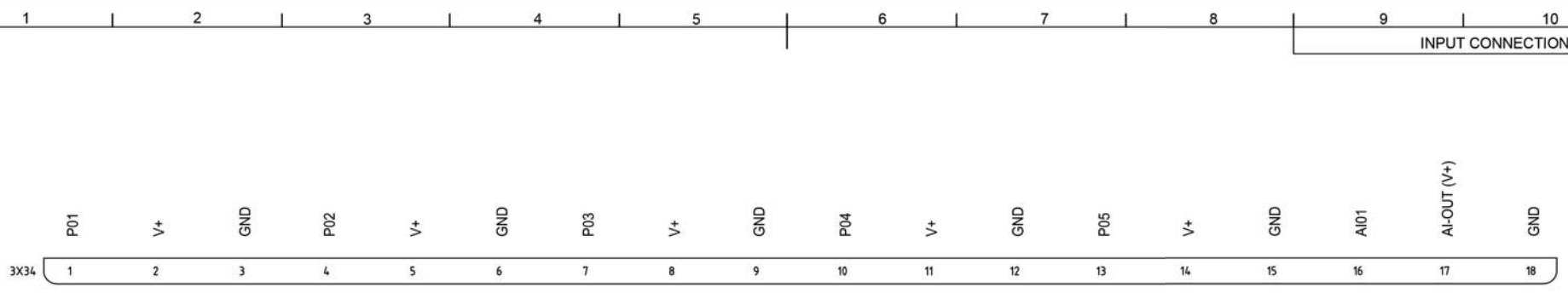

This document is the property of and shall not be used for purposes not intended without the express written permission of the manufacturer. It is to be used for manufacturing or communication to any other person or company.

ACD	Name	DIAGRAM SERVICE	LES 22-30	STATUS	Ed.	Date	Prev. Page 10	Next Page 12	A3	Designation	Sheet 11 (16)
	Drawing owner	Fixed speed, DOL starter		Approved	04	2014-08-08	Drawn by	AIR15507	Date	2012-03-22	<b>9820 4970 06</b>

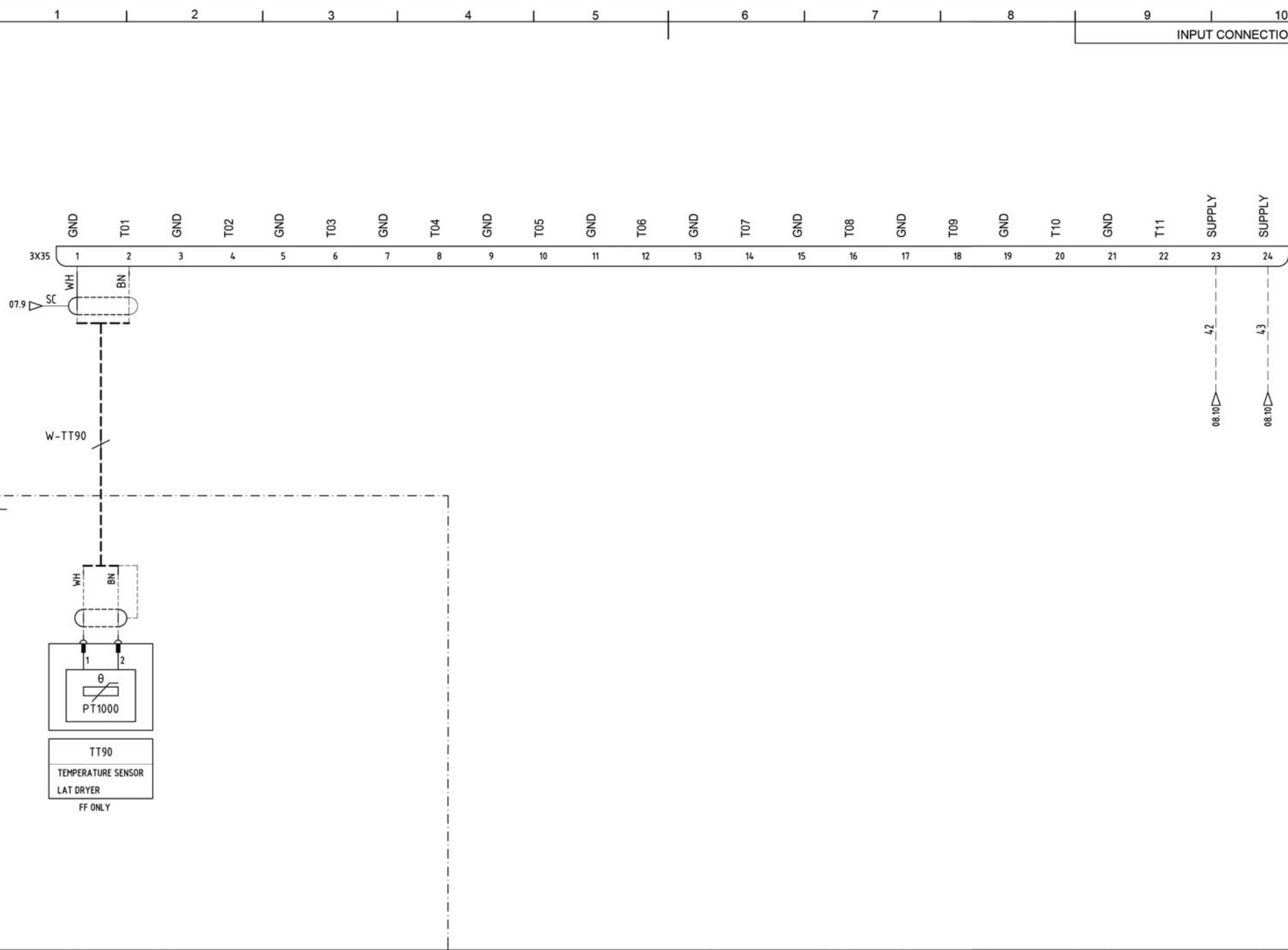

This document is the property of and shall not be used for purposes not intended without the express written permission of the manufacturer or communicated to any other person or company.

ACD	Name	DIAGRAM SERVICE	LES 22-30	STATUS	Ed.	Date	Prev. Page 11	Next Page 13	A3	Designation	Sheet 12 (16)
		Fixed speed, DOL starter					Approved	04			
Drawing owner	All						AIR15507	2012-03-22			

REMOTE EMERGENCY STOP [G]

AUXILIARY CONTACTS  
250VAC 10A AC1

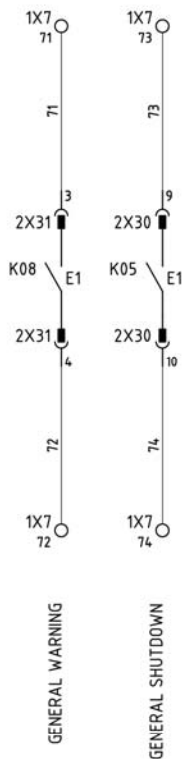
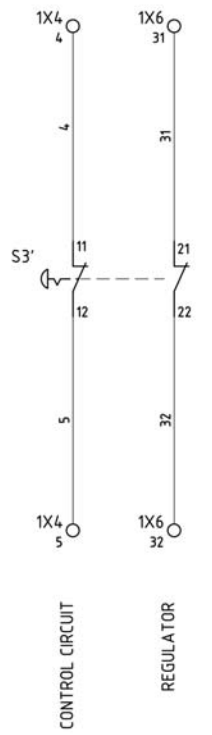

This document is the property of and shall not be used for purposes not intended without the written permission of the manufacturer. Copying, distribution, or communication to any other person or company is prohibited.

ACD	Name	DIAGRAM SERVICE	LES 22-30	STATUS	Ed.	Date	Prev. Page 12	Next Page 14	A3	Designation	Sheet 13 (16)
				Drawing owner	Approved		04	2014-08-08	Drawn by	Date	9820 4970 06
All		Fixed speed, DOL starter					AIR15507	2012-03-22			

LEGEND				
LOCATION	TAGNAME	PAGE	DESCRIPTION	FUNCTION
CANOPY	B1	05	ELECTRONIC WATER DRAIN	OPTION
CANOPY	M1	02	COMPRESSOR MOTOR	
CANOPY	M2	02	COMPRESSOR MOTOR	
CANOPY	M3	02	COMPRESSOR MOTOR	
CANOPY	M4	02	COMPRESSOR MOTOR	
CANOPY	M5	02	FAN MOTOR	
CANOPY	M6	05	FANMOTOR CANOPY	
CANOPY	PDS11	10	DD FILTER	
CANOPY	PDS12	10	PD FILTER	
CANOPY	PT20	08	PRESSURE TRANSDUCER	DELIVERY AIR
CANOPY	TSHH20	08	HIGH ELEMENT OUTLET	
CANOPY	TT01	09	TEMPERATURE SENSOR	AMBIENT
CANOPY	TT11	08	TEMPERATURE SENSOR	ELEMENT 1
CANOPY	TT12	08	TEMPERATURE SENSOR	ELEMENT 2
CANOPY	TT13	08	TEMPERATURE SENSOR	ELEMENT 3
CANOPY	TT14	09	TEMPERATURE SENSOR	ELEMENT 4
CANOPY	TT90	12	TEMPERATURE SENSOR	LAT DRYER
CONTROL PANEL	2X24	06	CONNECTOR	RJ11 - I/O
CONTROL PANEL	2X26	06	MEMORY CARD	
CONTROL PANEL	2X27	08	CONNECTOR	REGULATOR
CONTROL PANEL	2X28	09	CONNECTOR	REGULATOR
CONTROL PANEL	2X30	05	CONNECTOR OF E1	
CONTROL PANEL	2X31	05		
CONTROL PANEL	3X23	07	IO-IN	EXPANSION MODULE
CONTROL PANEL	3X33	10	CONNECTOR	EXPANSION MODULE
CONTROL PANEL	3X34	11	CONNECTOR	EXPANSION MODULE
CONTROL PANEL	3X35	12	CONNECTOR	EXPANSION MODULE
CONTROL PANEL	E1	06	REGULATOR	
CONTROL PANEL	E2	07	EXPANSION MODULE	
CONTROL PANEL	F1	04	FUSE	TRANSFORMER PROTECTION
CONTROL PANEL	F2	04	FUSE	TRANSFORMER PROTECTION
CONTROL PANEL	F4	04	FUSE	CONTROL CIRCUIT 115V
CONTROL PANEL	F5	04	FUSE	CONTROL CIRCUIT 24V
CONTROL PANEL	F6	04	FUSE	CONTROL CIRCUIT 24V
CONTROL PANEL	K15	05	FAN CONTACTOR	
CONTROL PANEL	K21	05	LINE CONTACTORS	
CONTROL PANEL	K22	05	LINE CONTACTORS	
CONTROL PANEL	K23	05	LINE CONTACTORS	

This document is the property of and shall not be used without the permission of the client. It is not to be used for manufacturing or communication to any other person or company.

ACD	Name	DIAGRAM SERVICE	LES 22-30	STATUS	Ed.	Date	Prev. Page 13	Next Page 15	A3	Designation	Sheet 14 (16)
	Drawing owner	Fixed speed, DOL starter		Approved	04	2014-08-08	Drawn by AIR15507	Date 2012-03-22		<b>9820 4970 06</b>	

A  
B  
C  
D  
E  
F  
G

LEGEND				
LOCATION	TAGNAME	PAGE	DESCRIPTION	FUNCTION
CONTROL PANEL	K24	05	LINE CONTACTOR	
CONTROL PANEL	Q15	02	MOTOR/STARTER PROTECTION	M5
CONTROL PANEL	Q21	02	MOTOR/STARTER PROTECTION	M1
CONTROL PANEL	Q22	02	MOTOR/STARTER PROTECTION	M2
CONTROL PANEL	Q23	02	MOTOR/STARTER PROTECTION	M3
CONTROL PANEL	Q24	02	MOTOR/STARTER PROTECTION	M4
CONTROL PANEL	S3	05	EMERGENCY STOP	
CONTROL PANEL	S6	09	REMOTE/LOCAL PRESSURE SENSING	
CONTROL PANEL	T1	04	TRANSFORMER	CONTROL CIRCUIT
CONTROL PANEL	X1	08	CONNECTOR	
CONTROL PANEL	X104	05	DRYER	
CONTROL PANEL	X104	05	DRYER	
CONTROL PANEL	X105	05	DRAIN	
CONTROL PANEL	X114	03	CONNECTOR	
CONTROL PANEL	X114	03	CONNECTOR	
CONTROL PANEL	X114	03	CONNECTOR	
CONTROL PANEL	X132	05	SUPPLY 115V	
CONTROL PANEL	X150	08	CONNECTOR	
CUSTOMER	F0	02	MAIN PROTECTION	CUSTOMER INSTALLATION
CUSTOMER	S0	02	MAIN SWITCH	CUSTOMER INSTALLATION
CUSTOMER	S1	08	REMOTE START/STOP	CUSTOMER
CUSTOMER	S3	13	REMOTE EMERGENCY STOP PUSH BUTTON	
DRYER	A1	03	DRYER	FULL FEATURE ONLY
DRYER	A1.1	03	DRYER	FULL FEATURE ONLY
DRYER	A1.2	03	DRYER	FULL FEATURE ONLY
DRYER	F10	03	FUSES	
DRYER	F11	03	FUSES	
DRYER	F7	03	FUSES	DRYER
DRYER	F8	03	FUSES	DRYER
DRYER	K11	05	AUXILIARY CONTACTOR	DRYER
DRYER	T3	03	AUTO TRANSFORMER	DRYER

This document is the property of and shall not be used for purposes not intended without the express written consent of the manufacturer or communicated to any other person or company.

ACD	Name	DIAGRAM SERVICE	LES 22-30	STATUS	Ed.	Date	Prev. Page 14	Next Page 16	A3	Designation	Sheet 15 (16)
	Drawing owner	Fixed speed, DOL starter		Approved	04	2014-08-08	Drawn by AIR15507	Date 2012-03-22	9820 4970 06		

A  
B  
C  
D  
E  
F  
G

**NOTES :**

- [A] Maximum fuses with regard to short circuit protection of starter. Cable section might impose fuses of smaller value.
- [B] Power supply to be connected for :  
COUNTER CLOCKwise rotation of motor  
Rotation to be observed while facing the drive end shaft of the motors.
- [C] NOT USED FOR SF17.
- [D] Only 200V and 230V units.
- [H] To connect correct transfo - voltage see on transfo.
- [G] Optional remote emergency stop :  
Replace bridge by NC contacts of remote emergency stop
- [E] Thightening torque for bolts :  
metric thread size M6 7Nm (5lbf)  
metric thread size M8 12Nm (9lbf)  
metric thread size M10 20Nm (15lbf)

- [I] For field wiring use copper wire only.
- [J] Not for CSA/UL

[F] For 380-400-460 50/60HZ

[F] For 200-230V 50/60HZ

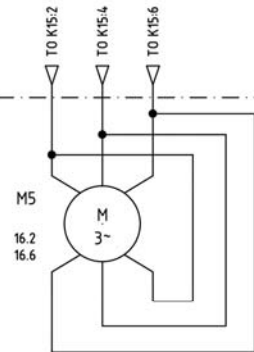
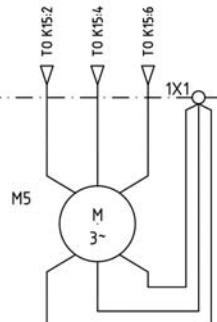

**Pressure transducer pin configuration**

- 1 : Supply voltage
- 2 : Ground
- 3 : Output
- 4 : Sealed with dummy

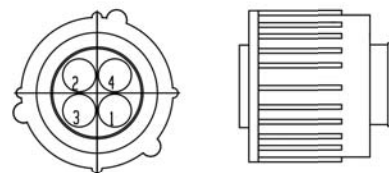

**Pressure difference transducer**

- 1 : Supply V+
- 2 : Ground
- 3 : Signal



**Marking of Connectors**

2X5, 2X6, 2X9, 2X10, 2X11

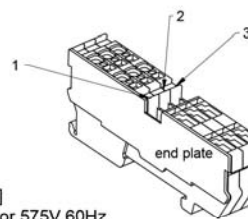
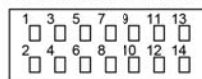

[F] For 575V 60Hz

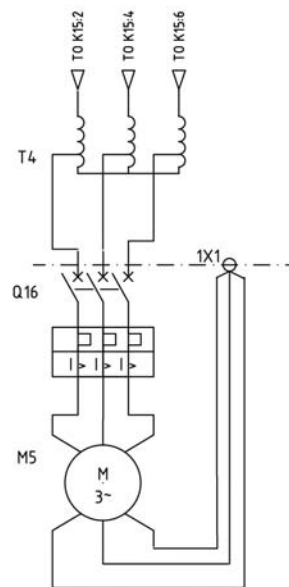

This document is the property of and shall not be used for permission to be offered, copied, used for manufacturing or communicated to any other person or company.

ACD	Name	DIAGRAM SERVICE
Drawing owner		Fixed speed, DOL starter
All		

LES 22-30

STATUS	Ed.	Date	Prev. Page	15	Next Page	A3	Designation	Sheet 16	(16)
Approved	04	2014-08-08	Drawn by	AIR15507	Date	2012-03-22	9820 4970 06		