

## **DPX Desiccant Retrofit Dryer Kit 7 - 25 SCFM SPECIFICATION**

### **Duplex System**

DPX Desiccant Retrofit Dryer kit with inlet flow up to 25 cfm is designed for retrofitting discontinued dryer used on LPS scroll air systems. The kit includes two twin tower desiccant dryers, pre-, afterfilters, regulators, safety relief valves, and integral purge saving control system. A dew point sensor and certifier's test port is included in the system. All of the above are pre-wired and pre-piped in accordance with the latest edition of NFPA 99, Standard for Healthcare Facilities. The system is completely pre-packaged for easy passage through a standard 34.5" door opening.

### **Dryer**

The dryer is a twin tower, pressure swing adsorption, regenerative type:

- Each desiccant dryer is individually sized for NFPA peak calculated demand
- Each dryer is capable of producing a 14°F (-10°C) pressure dew point at 100 psig inlet and 50 psig delivery
- Purge flow is minimized through an integral purge saving control system
- 441™ transfer valve per dryer with ceramic plate design to achieve tower changeover
- Easy alternation between on line/off line dryers by means of a valved bypass
- The dryer will use up to 15% of the system capacity to purge
- Maximum inlet temperature for dryer is 110°F
- Anodized aluminum blocks with o-ring seals and SAE o-ring fittings to eliminate leak points

### **Prefilter**

Fully duplexed prefilters shall be rated for 0.01 micron and capable of removing both aerosols and particulates. The prefilters shall be mounted and pre-piped with automatic float drain and element change indicator.

### **Afterfilter**

Fully duplexed afterfilters shall be rated for 1 micron particulates removal. The afterfilters shall be mounted and pre-piped with element change indicator.

### **Regulator / Safety Relief Valve**

Fully duplexed regulators shall be factory set at 55 PSI with safety relief valves rated for 75 PSI.

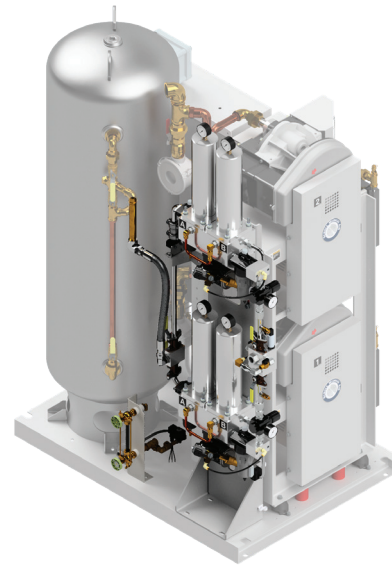

### **Dew Point**

The dryer incorporates a dew point transmitter that is a ceramic type sensor with  $\pm 2^\circ$  F system accuracy.

### **Control System**

In order to simplify upgrade, reduce down time retrofit dryer have to be designed to utilize existing control system, all its function including (but not limited to):

- Dew point monitoring
- Continuous and Controlled Purge
- Dryer selection

### **Note:**

Developed to retrofit discontinued pre-LDD dryer, used on LPS type scroll air systems.

**Standard Configuration**

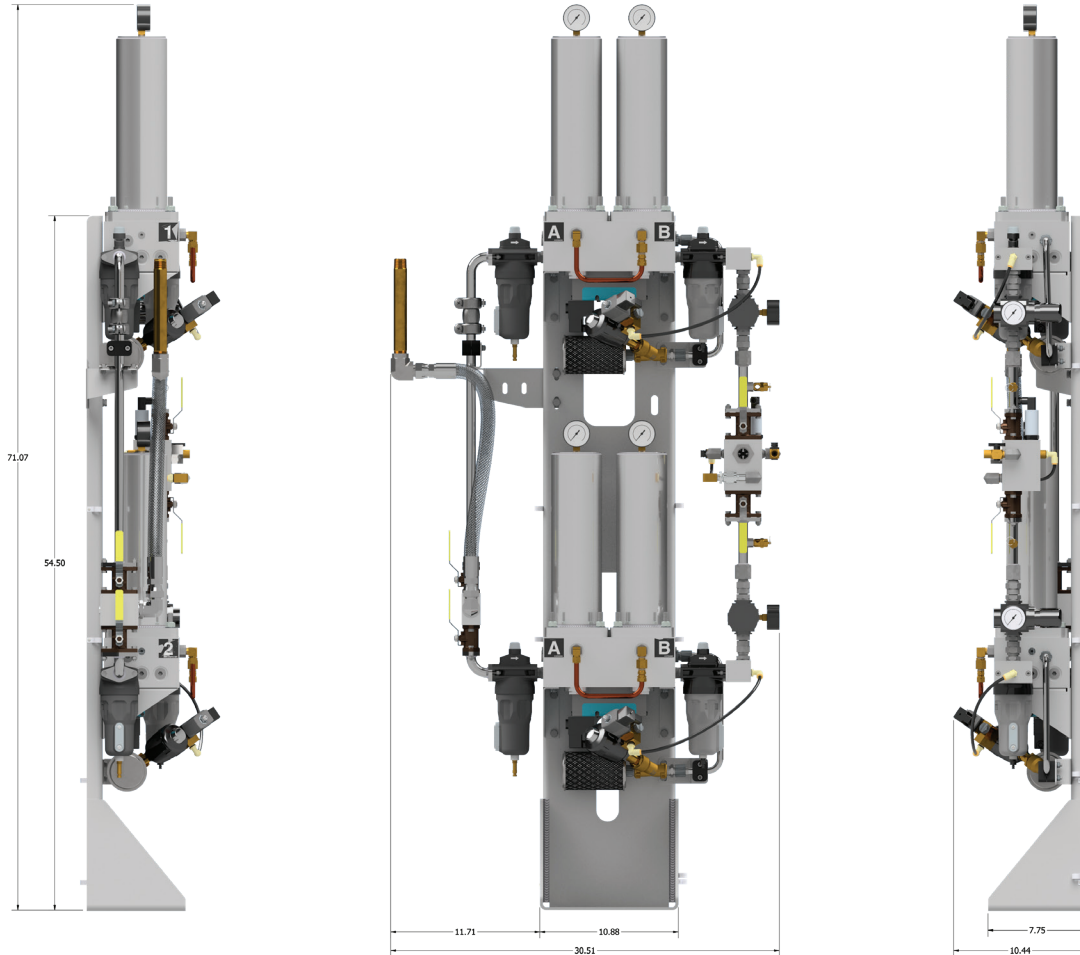

**Notes:**

Dryer Specification <sup>1</sup>				
Model No.	Inlet Flow (SCFM) at 55psig	Connections (NPT)		Weight (lbs)
		Inlet	Discharge	
4107401841	7-25	3/4"	3/4"	212

- Notes:**
1. Normal operating conditions at a maximum ambient of 105° F. Consult factory for higher ambient conditions.
  2. All capacities are shown as NFPA system capacities (reserve dryer on standby).
  3. Minimum Working Pressure: 60psig
  4. Maximum Working Pressure: 135 psig
  5. Maximum Inlet Temperature: 110°F